

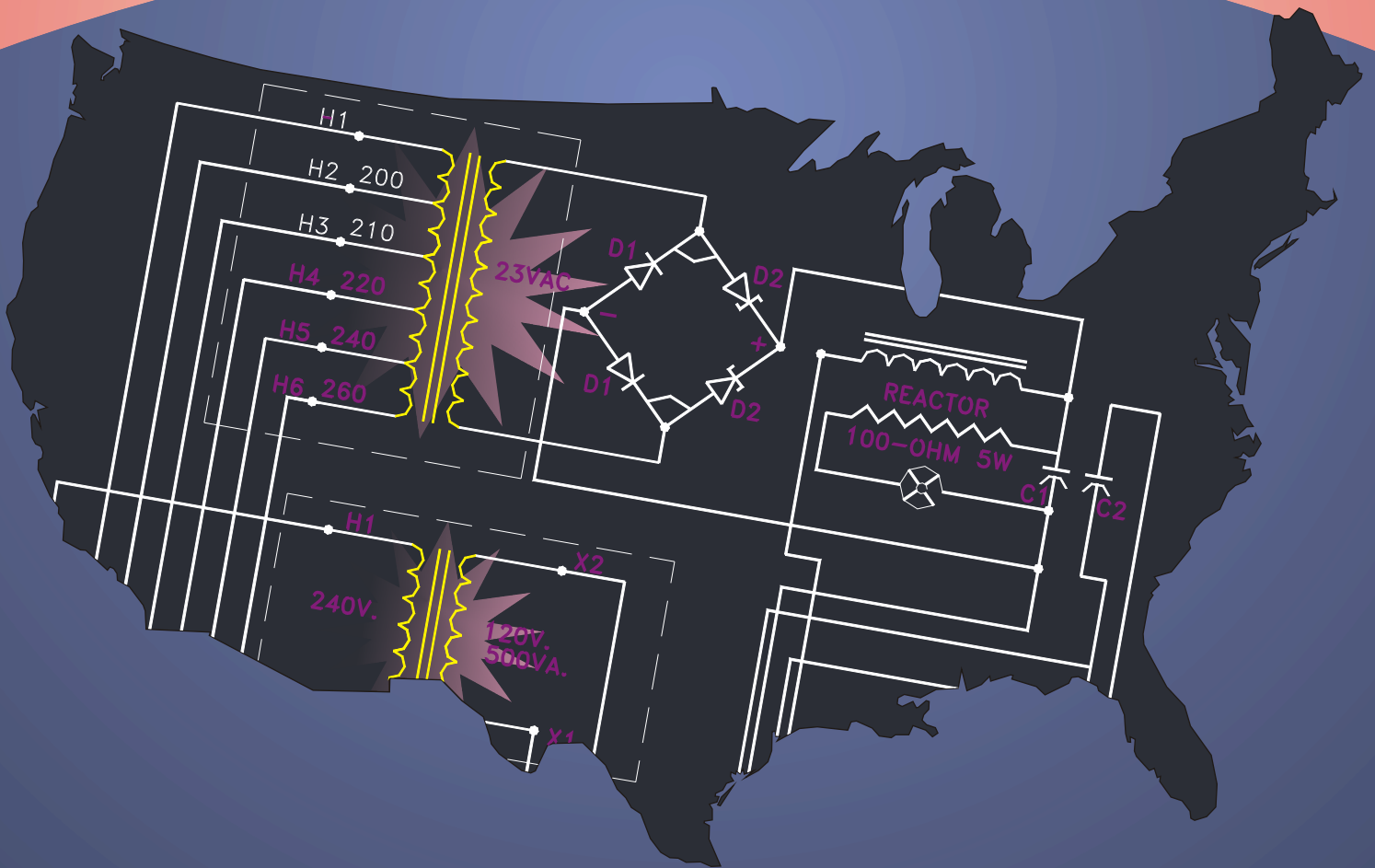

# **DONGAN**

## **TRANSFORMERS**



# Specialty Design Capability Targeted to Meet or Exceed Your Requirements

What do you do when you know the transformer you are looking for is not in **any** section of this catalog? Dongan Electric Manufacturing has a team ready to help take that custom requirement off your desk!

Dongan is well equipped to handle your OEM and Specialty Transformer Requirements. We have Agency Approvals allowing most custom transformers to be UL Approved and CSA Certified even if the quantity required is small. CE Marked,

TÜV Rheinland approved transformers are also available in a wide selection of voltage combinations.

Call today to obtain quotations on your specialty or custom needs. Delivery is prompt and accurate - designed to meet your needs and frequently in 2 to 3 weeks or less. CAD Drawings are available to present to your customer. Contact your Dongan Representative or the factory to receive an answer to your specialty requirements.

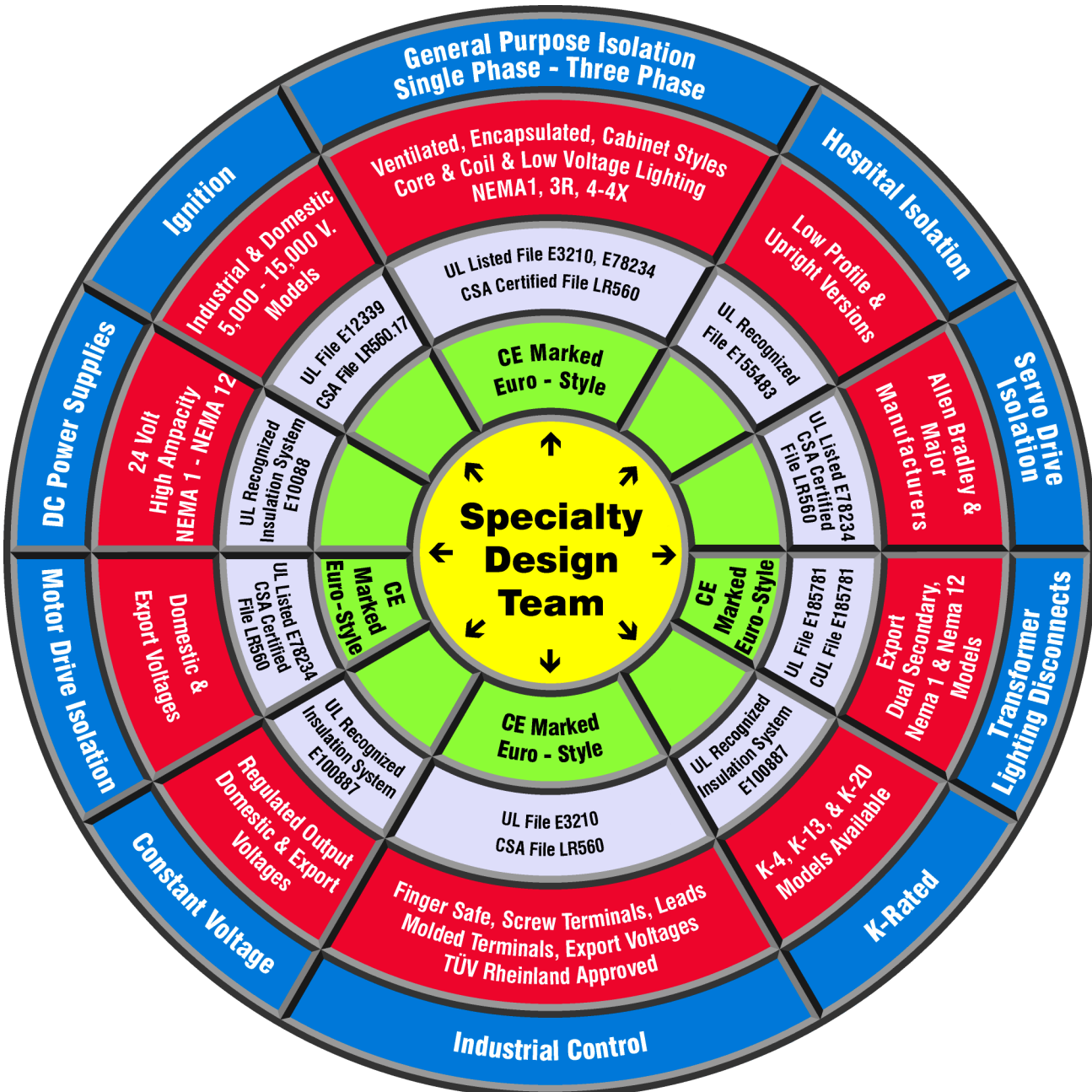



# Contents

Table of Contents .....	1
Alphanumeric Page Reference .....	2
Single Phase .....	5
Three Phase .....	25
Buck – Boost .....	47
Industrial Control Transformers .....	67
Servo Drive Isolation .....	88
Ignition Transformers .....	90
General Information .....	91

DONGAN ELECTRIC MANUFACTURING Co. • 2987 FRANKLIN • DETROIT, MI 48207  
800.428.2626 • 313.567.8500 • Fax 313.567.8828 • [www.dongan.com](http://www.dongan.com)



# Alphanumeric Page Reference

**DONGAN ELECTRIC MANUFACTURING CO. • 2987 FRANKLIN • DETROIT, MI 48207**  
**800.428.2626 • 313.567.8500 • FAX 313.567.8828 • www.dongan.com**

21HG-0301 .....	Page 23	35-1010 .....	Page 8	35-Y005 .....	Page 14	50-0375-134 .....	Page 73	63-0306 .....	Page 30
21HG-0302 .....	Page 23	35-1015 .....	Page 12	35-Y005 .....	Page 52	50-0500-052 .....	Page 70	63-0309 .....	Page 30
21HG-0304 .....	Page 23	35-1015 .....	Page 8	35-Y005 .....	Page 54	50-0500-053 .....	Page 71	63-0403SH .....	Page 38
21HG-0305 .....	Page 23	35-1020 .....	Page 12	35-Y005 .....	Page 57	50-0500-054 .....	Page 72	63-0406SH .....	Page 38
21HG-0308 .....	Page 23	35-1025 .....	Page 12	35-Y005 .....	Page 64	50-0500-056 .....	Page 72	63-0407SH .....	Page 38
21HG-0313 .....	Page 23	35-1030 .....	Page 12	35-Y005 .....	Page 65	50-0500-058 .....	Page 73	63-0503SH .....	Page 38
21HG-0501 .....	Page 23	35-2010 .....	Page 8	35-Y010 .....	Page 11	50-0500-059 .....	Page 73	63-0506SH .....	Page 38
21HG-0502 .....	Page 23	35-2015 .....	Page 8	35-Y010 .....	Page 14	50-0500-134 .....	Page 73	63-0507SH .....	Page 38
21HG-0504 .....	Page 23	35-2020 .....	Page 8	35-Y010 .....	Page 52	50-0750-052 .....	Page 70	63-0703SH .....	Page 38
21HG-0505 .....	Page 23	35-2025 .....	Page 8	35-Y010 .....	Page 54	50-0750-053 .....	Page 71	63-0706SH .....	Page 38
21HG-0508 .....	Page 23	35-2030 .....	Page 8	35-Y010 .....	Page 57	50-0750-054 .....	Page 72	63-0707SH .....	Page 38
21HG-0513 .....	Page 23	35-3010 .....	Page 12	35-Y010 .....	Page 64	50-0750-056 .....	Page 72	63-0803SH .....	Page 38
21HG-0701 .....	Page 23	35-3010 .....	Page 9	35-Y010 .....	Page 65	50-0750-058 .....	Page 73	63-0806SH .....	Page 38
21HG-0702 .....	Page 23	35-3015 .....	Page 12	35-Y015 .....	Page 11	50-0750-059 .....	Page 73	63-0807SH .....	Page 38
21HG-0704 .....	Page 23	35-3015 .....	Page 9	35-Y015 .....	Page 14	50-0750-134 .....	Page 73	63-0903SH .....	Page 38
21HG-0705 .....	Page 23	35-3020 .....	Page 12	35-Y015 .....	Page 52	50-1000-052 .....	Page 70	63-0906SH .....	Page 38
21HG-0708 .....	Page 23	35-3025 .....	Page 12	35-Y015 .....	Page 54	50-1000-053 .....	Page 71	63-0907SH .....	Page 38
21HG-0713 .....	Page 23	35-3030 .....	Page 12	35-Y015 .....	Page 57	50-1000-054 .....	Page 72	63-112-1161SH ..	Page 31
21HG-1001 .....	Page 23	35-4010 .....	Page 12	35-Y015 .....	Page 64	50-1000-056 .....	Page 72	63-112-1937 .....	Page 31
21HG-1002 .....	Page 23	35-4010 .....	Page 9	35-Y015 .....	Page 65	50-1000-058 .....	Page 73	63-112-264SH .....	Page 31
21HG-1004 .....	Page 23	35-4015 .....	Page 12	35-Y020 .....	Page 14	50-1000-059 .....	Page 73	63-112-2993 .....	Page 31
21HG-1005 .....	Page 23	35-4015 .....	Page 9	35-Y020 .....	Page 65	50-1000-134 .....	Page 73	63-112-2995SH ..	Page 31
21HG-1008 .....	Page 23	35-4020 .....	Page 12	35-Y025 .....	Page 14	50-1500-053 .....	Page 71	63-112-2996 .....	Page 31
21HG-1013 .....	Page 23	35-4025 .....	Page 12	35-Y025 .....	Page 65	50-1500-054 .....	Page 72	63-112-3117 .....	Page 31
21HG-1501 .....	Page 23	35-4030 .....	Page 12	35-Y030 .....	Page 14	50-1500-056 .....	Page 72	63-112-407 .....	Page 31
21HG-1501FM .....	Page 23	35-5010 .....	Page 10	35-Y030 .....	Page 65	50-1500-058 .....	Page 73	63-112-594 .....	Page 31
21HG-1502 .....	Page 23	35-5010 .....	Page 13	36-05-A .....	Page 21	50-1500-059 .....	Page 73	63-112-704SH .....	Page 31
21HG-1502FM .....	Page 23	35-5015 .....	Page 10	36-05-C .....	Page 21	50-1500-134 .....	Page 73	63-112-730 .....	Page 31
21HG-1504 .....	Page 23	35-5015 .....	Page 13	36-05-N .....	Page 21	50-2000-053 .....	Page 71	63-112-834 .....	Page 31
21HG-1504FM .....	Page 23	35-5020 .....	Page 13	36-10-A .....	Page 21	50-2000-054 .....	Page 72	63-15-1161SH .....	Page 31
21HG-1505 .....	Page 23	35-5025 .....	Page 13	36-10-C .....	Page 21	50-2000-056 .....	Page 72	63-15-1937 .....	Page 31
21HG-1505FM .....	Page 23	35-5030 .....	Page 13	36-10-N .....	Page 21	50-2000-058 .....	Page 73	63-15-264SH .....	Page 31
21HG-1508 .....	Page 23	35-6010 .....	Page 10	36-100-A .....	Page 21	50-2000-059 .....	Page 73	63-15-2993 .....	Page 31
21HG-1508FM .....	Page 23	35-6010 .....	Page 13	36-100-C .....	Page 21	50-2000-134 .....	Page 73	63-15-2995SH .....	Page 31
21HG-1513 .....	Page 23	35-6015 .....	Page 10	36-25-A .....	Page 21	50-3000-053 .....	Page 71	63-15-2996 .....	Page 31
21HG-1513FM .....	Page 23	35-6015 .....	Page 13	36-25-C .....	Page 21	50-3000-054 .....	Page 72	63-15-3117 .....	Page 31
21HG-2501FM .....	Page 23	35-6020 .....	Page 13	36-50-A .....	Page 21	50-3000-056 .....	Page 72	63-15-407 .....	Page 31
21HG-2502FM .....	Page 23	35-6025 .....	Page 13	36-50-C .....	Page 21	50-3000-058 .....	Page 73	63-15-594 .....	Page 31
21HG-2504FM .....	Page 23	35-6030 .....	Page 13	36-75-A .....	Page 21	50-3000-059 .....	Page 73	63-15-704SH .....	Page 31
21HG-2505FM .....	Page 23	35-LM010 .....	Page 11	36-75-C .....	Page 21	50-3000-134 .....	Page 73	63-15-730 .....	Page 31
21HG-2508FM .....	Page 23	35-LM010 .....	Page 14	50-0050-052 .....	Page 70	50-5000-053 .....	Page 71	63-15-834 .....	Page 31
21HG-2513FM .....	Page 23	35-LM010 .....	Page 55	50-0050-053 .....	Page 71	50-5000-058 .....	Page 73	63-150-1161SH ..	Page 31
21HG-3701FM .....	Page 23	35-LM010 .....	Page 58	50-0050-054 .....	Page 72	61-1460SH .....	Page 8	63-150-1937 .....	Page 31
21HG-3702FM .....	Page 23	35-LM010 .....	Page 64	50-0050-056 .....	Page 72	61-1465SH .....	Page 43	63-150-264SH .....	Page 31
21HG-3704FM .....	Page 23	35-LM010 .....	Page 65	50-0050-134 .....	Page 73	61-1465SH .....	Page 45	63-150-2993 .....	Page 31
21HG-3705FM .....	Page 23	35-LM015 .....	Page 11	50-0075-052 .....	Page 70	61-1465SH .....	Page 8	63-150-2995SH ..	Page 31
21HG-3708FM .....	Page 23	35-LM015 .....	Page 14	50-0075-053 .....	Page 71	61-1470SH .....	Page 43	63-150-2996 .....	Page 31
21HG-3713FM .....	Page 23	35-LM015 .....	Page 55	50-0075-054 .....	Page 72	61-1470SH .....	Page 45	63-150-3117 .....	Page 31
265 B .....	Page 70	35-LM015 .....	Page 58	50-0075-056 .....	Page 72	61-1470SH .....	Page 8	63-150-407 .....	Page 31
265 B .....	Page 71	35-LM015 .....	Page 64	50-0075-134 .....	Page 73	61-1475SH .....	Page 43	63-150-594 .....	Page 31
265 B .....	Page 72	35-LM015 .....	Page 65	50-0100-052 .....	Page 70	61-1475SH .....	Page 45	63-150-704SH .....	Page 31
265 B .....	Page 73	35-LM020 .....	Page 14	50-0100-053 .....	Page 71	61-1475SH .....	Page 8	63-150-730 .....	Page 31
265 B .....	Page 75	35-LM020 .....	Page 65	50-0100-054 .....	Page 72	61-1680SH .....	Page 43	63-150-834 .....	Page 31
33-050-17 .....	Page 20	35-LM025 .....	Page 14	50-0100-056 .....	Page 72	61-1680SH .....	Page 45	63-21118SH .....	Page 38
33-050-18 .....	Page 20	35-LM025 .....	Page 65	50-0100-134 .....	Page 73	61-1680SH .....	Page 8	63-2111SH .....	Page 38
33-050-26 .....	Page 20	35-LM030 .....	Page 14	50-0150-052 .....	Page 70	61-1685SH .....	Page 43	63-21145SH .....	Page 38
33-050-82 .....	Page 20	35-LM030 .....	Page 65	50-0150-053 .....	Page 71	61-1685SH .....	Page 45	63-2114SH .....	Page 38
33-050-H .....	Page 20	35-M005 .....	Page 11	50-0150-054 .....	Page 72	61-1685SH .....	Page 8	63-2120SH .....	Page 38
33-050-HLK .....	Page 20	35-M005 .....	Page 14	50-0150-056 .....	Page 72	61-1690SH .....	Page 43	63-2127SH .....	Page 38
33-050-K .....	Page 20	35-M005 .....	Page 52	50-0150-059 .....	Page 73	61-1690SH .....	Page 45	63-2134SH .....	Page 38
33-050-PM .....	Page 20	35-M005 .....	Page 53	50-0150-134 .....	Page 73	61-1690SH .....	Page 8	63-2140SH .....	Page 38
33-100-17 .....	Page 20	35-M005 .....	Page 56	50-0200-052 .....	Page 70	61-1695SH .....	Page 43	63-2151SH .....	Page 38
33-100-18 .....	Page 20	35-M005 .....	Page 64	50-0200-053 .....	Page 71	61-1695SH .....	Page 45	63-2163SH .....	Page 38
33-100-26 .....	Page 20	35-M005 .....	Page 65	50-0200-054 .....	Page 72	61-1695SH .....	Page 8	63-2175SH .....	Page 38
33-100-82 .....	Page 20	35-M010 .....	Page 11	50-0200-056 .....	Page 72	61-3470SH .....	Page 9	63-2193SH .....	Page 38
33-100-H .....	Page 20	35-M010 .....	Page 14	50-0200-134 .....	Page 73	61-3475SH .....	Page 9	63-24118SH .....	Page 38
33-100-HLK .....	Page 20	35-M010 .....	Page 52	50-0250-052 .....	Page 70	61-4470SH .....	Page 9	63-2411SH .....	Page 38
33-100-K .....	Page 20	35-M010 .....	Page 53	50-0250-053 .....	Page 71	61-4475SH .....	Page 9	63-24145SH .....	Page 38
33-100-PM .....	Page 20	35-M010 .....	Page 56	50-0250-054 .....	Page 72	61-5470SH .....	Page 10	63-2414SH .....	Page 38
33-150-PM .....	Page 20	35-M010 .....	Page 64	50-0250-056 .....	Page 72	61-5475SH .....	Page 10	63-2420SH .....	Page 38
33-250-PM .....	Page 20	35-M010 .....	Page 65	50-0250-058 .....	Page 73	61-5480SH .....	Page 10	63-2427SH .....	Page 38
34-280-ODY .....	Page 44	35-M015 .....	Page 11	50-0250-059 .....	Page 73	61-5485SH .....	Page 10	63-2434SH .....	Page 38
34-280-ODY .....	Page 52	35-M015 .....	Page 14	50-0250-134 .....	Page 73	61-5490SH .....	Page 10	63-2440SH .....	Page 38
34-280-ODY .....	Page 66	35-M015 .....	Page 52	50-0300-052 .....	Page 70	61-5495SH .....	Page 10	63-2451SH .....	Page 38
34-560-ODY .....	Page 44	35-M015 .....	Page 53	50-0300-053 .....	Page 71	61-6470SH .....	Page 10	63-2463SH .....	Page 38
34-560-ODY .....	Page 52	35-M015 .....	Page 56	50-0300-054 .....	Page 72	61-6475SH .....	Page 10	63-2475SH .....	Page 38
34-560-ODY .....	Page 66	35-M015 .....	Page 64	50-0300-056 .....	Page 72	63-0103SH .....	Page 38	63-2493SH .....	Page 38
34-840-ODY .....	Page 44	35-M015 .....	Page 65	50-0300-134 .....	Page 73	63-0106SH .....	Page 38	63-25118SH .....	Page 38
34-840-ODY .....	Page 52	35-M020 .....	Page 14	50-0375-052 .....	Page 70	63-0107SH .....	Page 38	63-2511SH .....	Page 38
34-840-ODY .....	Page 66	35-M020 .....	Page 65	50-0375-053 .....	Page 71	63-0203 .....	Page 30	63-25145SH .....	Page 38
35-1005 .....	Page 12	35-M030 .....	Page 14	50-0375-054 .....	Page 72	63-0206 .....	Page 30	63-2514SH .....	Page 38
35-1005 .....	Page 8	35-M030 .....	Page 65	50-0375-056 .....	Page 72	63-0209 .....	Page 30	63-2520SH .....	Page 38
35-1010 .....	Page 12	35-Y005 .....	Page 11	50-0375-059 .....	Page 73	63-0303 .....	Page 30	63-2527SH .....	Page 38





# Alphanumeric Page Reference

63-2534SH	Page 38	63-6225SH	Page 28	76-3-2996	Page 31	84-1120-ODY	Page 44	85-5060SH	Page 10
63-2540SH	Page 38	63-6230SH	Page 28	76-3-3117	Page 31	84-1120-ODY	Page 52	85-5065SH	Page 10
63-2551SH	Page 38	63-6245SH	Page 28	76-3-407	Page 31	84-1120-ODY	Page 66	85-5470SH	Page 10
63-2563SH	Page 38	63-6275SH	Page 28	76-3-594	Page 31	84-1500-3PTT	Page 44	85-5475SH	Page 10
63-2575SH	Page 38	63-63112SH	Page 28	76-3-704SH	Page 31	84-1690-ODY	Page 44	85-6020SH	Page 10
63-2593SH	Page 38	63-63150SH	Page 28	76-3-730	Page 31	84-1690-ODY	Page 52	85-6025SH	Page 10
63-27118SH	Page 38	63-6315SH	Page 28	76-3-834	Page 31	84-1690-ODY	Page 66	85-6030SH	Page 10
63-2711SH	Page 38	63-6325SH	Page 28	76-6-1161SH	Page 31	84-2250-ODY	Page 44	85-6035SH	Page 10
63-27145SH	Page 38	63-6330SH	Page 28	76-6-1937	Page 31	84-2250-ODY	Page 52	85-6040SH	Page 10
63-2714SH	Page 38	63-6345SH	Page 28	76-6-264SH	Page 31	84-2250-ODY	Page 66	85-6045SH	Page 10
63-2720SH	Page 38	63-6375SH	Page 28	76-6-2993	Page 31	84-2500-3PTT	Page 44	85-6050SH	Page 10
63-2727SH	Page 38	63-6615SH	Page 29	76-6-2995SH	Page 31	84-3300-ODY	Page 44	85-6055SH	Page 10
63-2734SH	Page 38	63-6625SH	Page 29	76-6-2996	Page 31	84-3300-ODY	Page 52	85-6060SH	Page 10
63-2740SH	Page 38	63-6630SH	Page 29	76-6-3117	Page 31	84-3300-ODY	Page 66	85-6065SH	Page 10
63-2751SH	Page 38	63-6645SH	Page 29	76-6-407	Page 31	84-3750-3PTT	Page 44	85-LM020	Page 11
63-2763SH	Page 38	63-75-1161SH	Page 31	76-6-594	Page 31	84-500-3PTT	Page 44	85-LM020	Page 55
63-2775SH	Page 38	63-75-1937	Page 31	76-6-704SH	Page 31	84-5000-3PTT	Page 44	85-LM020	Page 58
63-2793SH	Page 38	63-75-264SH	Page 31	76-6-730	Page 31	84-5600-ODY	Page 44	85-LM020	Page 64
63-28118SH	Page 38	63-75-2993	Page 31	76-6-834	Page 31	84-5600-ODY	Page 52	85-LM025	Page 11
63-2811SH	Page 38	63-75-2995SH	Page 31	76-9-1161SH	Page 31	84-5600-ODY	Page 66	85-LM025	Page 55
63-28145SH	Page 38	63-75-2996	Page 31	76-9-1937	Page 31	84-7500-3PTT	Page 44	85-LM025	Page 58
63-2814SH	Page 38	63-75-3117	Page 31	76-9-264SH	Page 31	85-1020SH	Page 8	85-LM025	Page 64
63-2820SH	Page 38	63-75-407	Page 31	76-9-2993	Page 31	85-1025SH	Page 43	85-LM030	Page 11
63-2827SH	Page 38	63-75-594	Page 31	76-9-2995SH	Page 31	85-1025SH	Page 45	85-LM030	Page 55
63-2834SH	Page 38	63-75-704SH	Page 31	76-9-2996	Page 31	85-1025SH	Page 8	85-LM030	Page 58
63-2840SH	Page 38	63-75-730	Page 31	76-9-3117	Page 31	85-1030SH	Page 43	85-LM030	Page 64
63-2851SH	Page 38	63-75-834	Page 31	76-9-407	Page 31	85-1030SH	Page 45	85-LM035	Page 11
63-2863SH	Page 38	63-LTF209SH	Page 35	76-9-594	Page 31	85-1030SH	Page 8	85-LM035	Page 55
63-2875SH	Page 38	63-LTF215SH	Page 35	76-9-704SH	Page 31	85-1035SH	Page 43	85-LM035	Page 58
63-2893SH	Page 38	63-LTF225SH	Page 35	76-9-730	Page 31	85-1035SH	Page 45	85-LM035	Page 64
63-29118SH	Page 38	63-LTF230SH	Page 35	76-9-834	Page 31	85-1035SH	Page 8	85-LM040	Page 11
63-2911SH	Page 38	63-LTF245SH	Page 35	80-1035	Page 12	85-1040SH	Page 43	85-LM040	Page 55
63-29145SH	Page 38	63-LTF275SH	Page 35	80-1040	Page 12	85-1040SH	Page 45	85-LM040	Page 58
63-2914SH	Page 38	63-LTF309SH	Page 35	80-1045	Page 12	85-1040SH	Page 8	85-LM040	Page 64
63-2920SH	Page 38	63-LTF315SH	Page 35	80-1050	Page 12	85-1045SH	Page 43	85-LM045	Page 11
63-2927SH	Page 38	63-LTF325SH	Page 35	80-1055	Page 12	85-1045SH	Page 45	85-LM045	Page 55
63-2934SH	Page 38	63-LTF330SH	Page 35	80-2035	Page 8	85-1045SH	Page 8	85-LM045	Page 58
63-2940SH	Page 38	63-LTF345SH	Page 35	80-2040	Page 8	85-1050SH	Page 43	85-LM045	Page 64
63-2951SH	Page 38	63-LTF375SH	Page 35	80-3035	Page 12	85-1050SH	Page 45	85-LM050	Page 11
63-2963SH	Page 38	63-LTH209SH	Page 35	80-3040	Page 12	85-1050SH	Page 8	85-LM050	Page 55
63-2975SH	Page 38	63-LTH2112SH	Page 35	80-4035	Page 12	85-1055SH	Page 43	85-LM050	Page 58
63-2993SH	Page 38	63-LTH215SH	Page 35	80-4040	Page 12	85-1055SH	Page 45	85-LM050	Page 64
63-30-1161SH	Page 31	63-LTH225SH	Page 35	80-5035	Page 13	85-1055SH	Page 8	85-LM055	Page 11
63-30-1937	Page 31	63-LTH230SH	Page 35	80-5040	Page 13	85-1060SH	Page 43	85-LM055	Page 55
63-30-264SH	Page 31	63-LTH245SH	Page 35	80-6035	Page 13	85-1060SH	Page 45	85-LM055	Page 58
63-30-2993	Page 31	63-LTH275SH	Page 35	80-6040	Page 13	85-1060SH	Page 8	85-LM055	Page 64
63-30-2995SH	Page 31	63-LTH309SH	Page 35	80-7235	Page 13	85-1065SH	Page 8	85-M020	Page 11
63-30-2996	Page 31	63-LTH3112SH	Page 35	80-7240	Page 13	85-1070SH	Page 8	85-M020	Page 52
63-30-3117	Page 31	63-LTH315SH	Page 35	80-7245	Page 13	85-1075SH	Page 8	85-M020	Page 53
63-30-407	Page 31	63-LTH325SH	Page 35	80-7250	Page 13	85-1450SH	Page 8	85-M020	Page 56
63-30-594	Page 31	63-LTH330SH	Page 35	80-7255	Page 13	85-1455SH	Page 8	85-M020	Page 64
63-30-704SH	Page 31	63-LTH345SH	Page 35	80-LM035	Page 14	85-1460SH	Page 8	85-M025	Page 11
63-30-730	Page 31	63-LTH375SH	Page 35	80-LM035	Page 65	85-1465SH	Page 8	85-M025	Page 52
63-30-834	Page 31	76-0003SH	Page 29	80-LM040	Page 14	85-1470SH	Page 8	85-M025	Page 53
63-45-1161SH	Page 31	76-0006SH	Page 29	80-LM040	Page 65	85-1475SH	Page 8	85-M025	Page 56
63-45-1937	Page 31	76-0009SH	Page 29	80-LM045	Page 14	85-3020SH	Page 9	85-M025	Page 64
63-45-264SH	Page 31	76-01003SH	Page 29	80-LM045	Page 65	85-3025SH	Page 9	85-M030	Page 11
63-45-2993	Page 31	76-01006SH	Page 29	80-LM050	Page 14	85-3030SH	Page 9	85-M030	Page 52
63-45-2995SH	Page 31	76-01009SH	Page 29	80-LM050	Page 65	85-3035SH	Page 9	85-M030	Page 53
63-45-2996	Page 31	76-0203SH	Page 28	80-LM055	Page 14	85-3040SH	Page 9	85-M030	Page 56
63-45-3117	Page 31	76-0206SH	Page 28	80-LM055	Page 65	85-3045SH	Page 9	85-M030	Page 64
63-45-407	Page 31	76-0209SH	Page 28	80-M035	Page 14	85-3050SH	Page 9	85-M035	Page 11
63-45-594	Page 31	76-0303SH	Page 28	80-M035	Page 65	85-3055SH	Page 9	85-M035	Page 52
63-45-704SH	Page 31	76-0306SH	Page 28	80-M040	Page 14	85-3060SH	Page 9	85-M035	Page 53
63-45-730	Page 31	76-0309SH	Page 28	80-M040	Page 65	85-3065SH	Page 9	85-M035	Page 56
63-45-834	Page 31	76-0603SH	Page 29	80-M045	Page 14	85-4020SH	Page 9	85-M035	Page 64
63-60112SH	Page 29	76-0606SH	Page 29	80-M045	Page 65	85-4025SH	Page 9	85-M040	Page 11
63-60150SH	Page 29	76-0609SH	Page 29	80-M050	Page 14	85-4030SH	Page 9	85-M040	Page 52
63-6015SH	Page 29	76-2015SH	Page 34	80-M050	Page 65	85-4035SH	Page 9	85-M040	Page 53
63-6025SH	Page 29	76-2025SH	Page 34	80-M055	Page 14	85-4040SH	Page 9	85-M040	Page 56
63-6030SH	Page 29	76-2030SH	Page 34	80-M055	Page 65	85-4045SH	Page 9	85-M040	Page 64
63-6045SH	Page 29	76-2045SH	Page 34	80-Y035	Page 14	85-4050SH	Page 9	85-M045	Page 11
63-6075SH	Page 29	76-2075SH	Page 34	80-Y035	Page 65	85-4055SH	Page 9	85-M045	Page 52
63-610112SH	Page 29	76-2315SH	Page 34	80-Y040	Page 14	85-4060SH	Page 9	85-M045	Page 53
63-610150SH	Page 29	76-2325SH	Page 34	80-Y040	Page 65	85-4065SH	Page 9	85-M045	Page 56
63-61015SH	Page 29	76-2330SH	Page 34	80-Y045	Page 14	85-5020SH	Page 10	85-M045	Page 64
63-61025SH	Page 29	76-2345SH	Page 34	80-Y045	Page 65	85-5025SH	Page 10	85-M050	Page 11
63-61030SH	Page 29	76-2375SH	Page 34	80-Y050	Page 14	85-5030SH	Page 10	85-M050	Page 52
63-61045SH	Page 29	76-3-1161SH	Page 31	80-Y050	Page 65	85-5035SH	Page 10	85-M050	Page 53
63-61075SH	Page 29	76-3-1937	Page 31	80-Y055	Page 14	85-5040SH	Page 10	85-M050	Page 56
63-62112SH	Page 28	76-3-264SH	Page 31	80-Y055	Page 65	85-5045SH	Page 10	85-M050	Page 64
63-62150SH	Page 28	76-3-2993	Page 31	84-1000-3PTT	Page 44	85-5050SH	Page 10	85-M055	Page 11
63-6215SH	Page 28	76-3-2995SH	Page 31	84-10000-3PTT	Page 44	85-5055SH	Page 10	85-M055	Page 52

DONGAN ELECTRIC MANUFACTURING Co. • 2987 FRANKLIN • DETROIT, MI 48207  
 800.428.2626 • 313.567.8500 • Fax 313.567.8828 • www.dongan.com





# Alphanumeric Page Reference

**DONGAN ELECTRIC MANUFACTURING Co. • 2987 FRANKLIN • DETROIT, MI 48207**  
**800.428.2626 • 313.567.8500 • FAX 313.567.8828 • www.dongan.com**

85-M055	Page 53	AP12-651	Page 84	ES-10230.376	Page 82	GLF 1	Page 70	HL12-3030SH	Page 22
85-M055	Page 56	AP12-652	Page 84	ES-10230.386	Page 82	GLF 1	Page 71	HL12-3035SH	Page 22
85-M055	Page 64	AP12-653	Page 84	ES-10250.326	Page 82	GLF 1	Page 72	HL12-3040SH	Page 22
85-Y020	Page 11	AP12-654	Page 84	ES-10250.376	Page 82	GLF 1	Page 73	HL12-3045SH	Page 22
85-Y020	Page 52	BR-734-1	Page 70	ES-10250.386	Page 82	GLF 1	Page 75	HL12-3050SH	Page 22
85-Y020	Page 54	BR-734-1	Page 71	ES-10300.326	Page 82	HC-0050-41	Page 76	HL12-3055SH	Page 22
85-Y020	Page 57	BR-734-1	Page 72	ES-10300.376	Page 82	HC-0050-4100	Page 77	HL12-3060SH	Page 22
85-Y020	Page 64	BR-734-1	Page 73	ES-10300.386	Page 82	HC-0050-44	Page 78	HL12-3065SH	Page 22
85-Y025	Page 11	BR-734-1	Page 75	ES-11130.326	Page 18	HC-0050-4400	Page 78	HL12-3070SH	Page 22
85-Y025	Page 52	BR-734-2	Page 70	ES-11130.359	Page 18	HC-0050-46	Page 78	HL12-3075SH	Page 22
85-Y025	Page 54	BR-734-2	Page 71	ES-11170.326	Page 18	HC-0050-47	Page 79	HL12-4025SH	Page 22
85-Y025	Page 57	BR-734-2	Page 72	ES-11170.359	Page 18	HC-0075-41	Page 76	HL12-4030SH	Page 22
85-Y025	Page 64	BR-734-2	Page 73	ES-11190.326	Page 18	HC-0075-4100	Page 77	HL12-4035SH	Page 22
85-Y030	Page 11	BR-734-2	Page 75	ES-11190.359	Page 18	HC-0075-44	Page 78	HL12-4040SH	Page 22
85-Y030	Page 52	BR-734-3	Page 70	ES-11200.326	Page 18	HC-0075-4400	Page 78	HL12-4045SH	Page 22
85-Y030	Page 54	BR-734-3	Page 71	ES-11200.359	Page 18	HC-0075-46	Page 78	HL12-4050SH	Page 22
85-Y030	Page 57	BR-734-3	Page 72	ES-11210.326	Page 18	HC-0075-47	Page 79	HL12-4055SH	Page 22
85-Y030	Page 64	BR-734-3	Page 73	ES-11210.359	Page 18	HC-0100-41	Page 76	HL12-4060SH	Page 22
85-Y035	Page 11	BR-734-3	Page 75	ES-11230.326	Page 18	HC-0100-4100	Page 77	HL12-4065SH	Page 22
85-Y035	Page 52	BR-734-4	Page 70	ES-11230.359	Page 18	HC-0100-44	Page 78	HL12-4070SH	Page 22
85-Y035	Page 54	BR-734-4	Page 71	ES-11250.326	Page 18	HC-0100-4400	Page 78	HL12-4075SH	Page 22
85-Y035	Page 57	BR-734-4	Page 72	ES-11250.359	Page 18	HC-0100-46	Page 78	HL12-5025SH	Page 22
85-Y035	Page 64	BR-734-4	Page 73	ES-11300.326	Page 18	HC-0100-47	Page 79	HL12-5030SH	Page 22
85-Y040	Page 11	BR-734-4	Page 75	ES-11300.359	Page 18	HC-0150-41	Page 76	HL12-5035SH	Page 22
85-Y040	Page 52	BR-734-5	Page 73	ES-11330.326	Page 18	HC-0150-4100	Page 77	HL12-5040SH	Page 22
85-Y040	Page 54	BR-734-5	Page 75	ES-11330.359	Page 18	HC-0150-44	Page 78	HL12-5045SH	Page 22
85-Y040	Page 57	BR-734-6	Page 70	ES-11360.326	Page 18	HC-0150-4400	Page 78	HL12-5050SH	Page 22
85-Y040	Page 64	BR-734-6	Page 71	ES-11360.359	Page 18	HC-0150-46	Page 78	HL12-5055SH	Page 22
85-Y045	Page 11	BR-734-6	Page 72	ES-11380.326	Page 18	HC-0150-47	Page 79	HL12-5060SH	Page 22
85-Y045	Page 52	BR-734-6	Page 73	ES-11380.359	Page 18	HC-0250-41	Page 76	HL12-5065SH	Page 22
85-Y045	Page 54	BR-734-6	Page 75	ES-11410.326	Page 18	HC-0250-4100	Page 77	HL12-5070SH	Page 22
85-Y045	Page 57	BR-734-7	Page 71	ES-11410.359	Page 18	HC-0250-44	Page 78	HL12-5075SH	Page 22
85-Y045	Page 64	BR-734-7	Page 72	ES-31200.542	Page 37	HC-0250-4400	Page 78	HL12-6025SH	Page 22
85-Y050	Page 11	BR-734-7	Page 73	ES-31200.552	Page 37	HC-0250-46	Page 78	HL12-6030SH	Page 22
85-Y050	Page 52	BR-734-7	Page 75	ES-31250.542	Page 37	HC-0250-47	Page 79	HL12-6035SH	Page 22
85-Y050	Page 54	BR-734-8	Page 71	ES-31250.552	Page 37	HC-0375-41	Page 76	HL12-6040SH	Page 22
85-Y050	Page 57	BR-734-8	Page 72	ES-31310.542	Page 37	HC-0375-4100	Page 77	HL12-6045SH	Page 22
85-Y050	Page 64	BR-734-8	Page 73	ES-31310.552	Page 37	HC-0375-44	Page 78	HL12-6050SH	Page 22
85-Y055	Page 11	BR-734-8	Page 75	ES-31360.542	Page 37	HC-0375-4400	Page 78	HL12-6055SH	Page 22
85-Y055	Page 52	BR-734-9	Page 73	ES-31360.552	Page 37	HC-0375-46	Page 78	HL12-6060SH	Page 22
85-Y055	Page 54	BR-734-9	Page 75	ES-31380.542	Page 37	HC-0375-47	Page 79	HL12-6065SH	Page 22
85-Y055	Page 57	BR-890	Page 24	ES-31380.552	Page 37	HC-0500-41	Page 76	HL12-6070SH	Page 22
85-Y055	Page 64	BR-890	Page 27	ES-31390.542	Page 37	HC-0500-4100	Page 77	HL12-6075SH	Page 22
A05-SA6	Page 90	BR-890	Page 46	ES-31390.552	Page 37	HC-0500-44	Page 78	N10-LF3	Page 90
A05-SC7	Page 90	BR-890	Page 7	ES-31410.542	Page 37	HC-0500-4400	Page 78	SDA-141012A	Page 88
A06-SA21	Page 90	BR-892	Page 24	ES-31410.552	Page 37	HC-0500-46	Page 78	SDA-141025A	Page 88
A06-SA6	Page 90	BR-892	Page 27	ES-31420.542	Page 37	HC-0500-47	Page 79	SDA-141050A	Page 88
A06-SA6X	Page 90	BR-892	Page 46	ES-31420.552	Page 37	HC-0750-41	Page 76	SDA-141075A	Page 88
A06-SD7	Page 90	BR-892	Page 7	ES-31450.542	Page 37	HC-0750-4100	Page 77	SDA-141100A	Page 88
A08-SA1	Page 90	C06-SA6	Page 90	ES-31450.552	Page 37	HC-0750-44	Page 78	SDA-241012A	Page 88
A10-LA2	Page 90	C10-LA2	Page 90	F06-SA6	Page 90	HC-0750-4400	Page 78	SDA-241025A	Page 88
A10-LA22	Page 90	C10-LF3	Page 90	FKP1	Page 76	HC-0750-46	Page 78	SDA-241050A	Page 88
A10-LA2X	Page 90	E05-SA6	Page 90	FKP2	Page 78	HC-0750-47	Page 79	SDA-241075A	Page 88
A10-LF3	Page 90	ES-10100.326	Page 82	FKP2	Page 79	HC-1000-41	Page 76	SDA-241100A	Page 88
A10-LF3X	Page 90	ES-10100.366	Page 82	FKS	Page 80	HC-1000-4100	Page 77	SDA-341012A	Page 88
A10-LN2X	Page 90	ES-10100.376	Page 82	FP12-351	Page 85	HC-1000-44	Page 78	SDA-341025A	Page 88
A15-LA6	Page 90	ES-10100.386	Page 82	FP12-352	Page 85	HC-1000-4400	Page 78	SDA-341050A	Page 88
A15-LA61	Page 90	ES-10130.326	Page 82	FP12-353	Page 85	HC-1000-46	Page 78	SDA-341075A	Page 88
A20-LA7	Page 90	ES-10130.366	Page 82	FP12-354	Page 85	HC-1000-47	Page 79	SDA-341100A	Page 88
AP12-351	Page 84	ES-10130.376	Page 82	FP12-401	Page 85	HC-1500-41	Page 76	TK04-63112SH	Page 40
AP12-352	Page 84	ES-10130.386	Page 82	FP12-402	Page 85	HC-1500-4100	Page 77	TK04-63150SH	Page 40
AP12-353	Page 84	ES-10150.326	Page 82	FP12-403	Page 85	HC-1500-44	Page 78	TK04-6315SH	Page 40
AP12-354	Page 84	ES-10150.366	Page 82	FP12-404	Page 85	HC-1500-4400	Page 78	TK04-6330SH	Page 40
AP12-401	Page 84	ES-10150.376	Page 82	FP12-451	Page 85	HC-1500-46	Page 78	TK04-6345SH	Page 40
AP12-402	Page 84	ES-10150.386	Page 82	FP12-452	Page 85	HC-1500-47	Page 79	TK04-6375SH	Page 40
AP12-403	Page 84	ES-10170.326	Page 82	FP12-453	Page 85	HC-2000-41	Page 76	TK13-63112SH	Page 41
AP12-404	Page 84	ES-10170.366	Page 82	FP12-454	Page 85	HC-2000-4100	Page 77	TK13-63150SH	Page 41
AP12-451	Page 84	ES-10170.376	Page 82	FP12-501	Page 85	HC-2000-44	Page 78	TK13-6315SH	Page 41
AP12-452	Page 84	ES-10170.386	Page 82	FP12-502	Page 85	HC-2000-4400	Page 78	TK13-6330SH	Page 41
AP12-453	Page 84	ES-10190.326	Page 82	FP12-503	Page 85	HC-2000-46	Page 78	TK13-6345SH	Page 41
AP12-454	Page 84	ES-10190.366	Page 82	FP12-504	Page 85	HC-2000-47	Page 79	TK13-6375SH	Page 41
AP12-501	Page 84	ES-10190.376	Page 82	FP12-551	Page 85	HL12-1025SH	Page 22	TK20-63112SH	Page 41
AP12-502	Page 84	ES-10190.386	Page 82	FP12-552	Page 85	HL12-1030SH	Page 22	TK20-63150SH	Page 41
AP12-503	Page 84	ES-10200.326	Page 82	FP12-553	Page 85	HL12-1035SH	Page 22	TK20-6315SH	Page 41
AP12-504	Page 84	ES-10200.366	Page 82	FP12-554	Page 85	HL12-1040SH	Page 22	TK20-6330SH	Page 41
AP12-551	Page 84	ES-10200.376	Page 82	FP12-601	Page 85	HL12-1045SH	Page 22	TK20-6345SH	Page 41
AP12-552	Page 84	ES-10200.386	Page 82	FP12-602	Page 85	HL12-1050SH	Page 22	TK20-6375SH	Page 41
AP12-553	Page 84	ES-10210.326	Page 82	FP12-603	Page 85	HL12-1055SH	Page 22		
AP12-554	Page 84	ES-10210.366	Page 82	FP12-604	Page 85	HL12-1060SH	Page 22		
AP12-601	Page 84	ES-10210.376	Page 82	FP12-651	Page 85	HL12-1065SH	Page 22		
AP12-602	Page 84	ES-10210.386	Page 82	FP12-652	Page 85	HL12-1070SH	Page 22		
AP12-603	Page 84	ES-10230.326	Page 82	FP12-653	Page 85	HL12-1075SH	Page 22		
AP12-604	Page 84	ES-10230.366	Page 82	FP12-654	Page 85	HL12-3025SH	Page 22		

# Single Phase Transformers

## Contents

Single Phase - General Purpose .....	6
Single Phase - Low Voltage .....	11
Single Phase - General Purpose Ventilated .....	12
Single Phase - Connection Diagrams .....	15
Series ES-11 CE Marked Single Phase Transformers .....	18
Series 33 - Control Transformers .....	20
Series 36 - Signaling .....	21
Series HL - Hazardous Location .....	22
Series 21 HG - Hospital Isolation Transformers .....	23
Single Phase Outline Drawings .....	24



DONGAN ELECTRIC MANUFACTURING Co. • 2987 FRANKLIN • DETROIT, MI 48207  
 800.428.2626 • 313.567.8500 • Fax 313.567.8828 • www.dongan.com



### SINGLE PHASE VENTILATED:

Series 35: .050 kVA - .750 kVA – Series 80: 1.0 kVA - 5.0 kVA

#### Features

- **UL Listed, File E3210.**
- **CSA Certified, File LR 560.**
- **Copper windings** and copper lead wire terminations used throughout.
- **Series 35 has a UL Class 105°C insulation system** with 55°C temperature rise at a maximum ambient of 40°C. This insures a long life and cool operating temperatures.
- **Series 80 has a UL Class 180°C insulation system** with 115°C temperature rise at a maximum ambient of 40°C.
- **NEMA-3R**, wall mount enclosure suitable for indoor or outdoor use. May be used in banks of 2 or 3 units for standard three phase voltages

and nonstandard, open delta auto-transformer applications. (Note: .050 kVA - .100 kVA are in a NEMA-1 enclosure)

- **Multiple knockouts** provide convenient conduit entry and exit locations through the front access wiring compartment.
- **Ground studs** provided for bonding compatibility with both metallic and nonmetallic conduit.
- **Nonstandard designs** are available by consulting the factory or your Dongan representative.
- Double wound, isolation type transformers.



### SINGLE PHASE ENCAPSULATED:

Series 85 ISO-Shield: .250 kVA - 25 kVA

#### Features

- **UL Listed, File E3210, .250 - 10 kVA.**
- **UL Listed, File E78234, 15 - 25 kVA.**
- **CUL Listed through UL File E3210.**
- **Electrostatic shield** between primary and secondary windings provides cleaner output voltage and helps to reduce spikes and transients.

- **Epoxy-silica encapsulated** core and coil provides a transformer particularly well suited for harsh commercial and industrial applications.
- **Copper windings** and copper lead wire terminations used throughout.
- **UL Class 180°C insulation system** with 115°C temperature rise at a maximum ambient of 40°C.
- **NEMA-3R**, wall mount enclosure suitable for indoor or outdoor use. May be used in banks of 2 or 3 units for standard three phase voltages and nonstandard, open delta autotransformer applications.
- **Multiple knockouts** provide convenient conduit entry and exit locations through the front and bottom access wiring compartment covers.
- **Ground studs** provided for bonding compatibility with both metallic and nonmetallic conduit.
- **Nonstandard designs** are available by consulting the factory or your Dongan representative.
- Double wound, isolation type transformers.



## Single Phase - General Purpose

### SINGLE PHASE VENTILATED CABINET STYLE:

Series 61 ISO-Shield: 7.5 kVA - 100 kVA

#### Features

- **UL Listed, File E78234.**
- **CUL Listed through UL File E3210.**
- **Electrostatic shield** between primary and secondary windings provides cleaner output voltage and helps to reduce spikes and transients.
- **Aluminum windings** connect to bus bar style terminations equipped with NEMA standard holes for compression style or ring terminals.



- **UL Class 220°C insulation system** with a 150°C temperature rise at full load and a maximum ambient of 40°C.
- **NEMA-3R**, ventilated, cabinet style, floor mount enclosure suitable for indoor or outdoor use. **No extra rainshields required for outdoor use.** May also be used in banks of 2 or 3 units for three phase isolation or autotransformer applications.
- **Vibration dampening pads** provide quiet operation.
- **Wall Mounting brackets** are available in sizes up to 50 kVA
- **Ground studs** provided for bonding compatibility with both metallic and nonmetallic conduit.
- **Core and coil and nonstandard designs** are available by consulting the factory or your Dongan representative.
- Double wound, isolation type transformers.

### SINGLE PHASE: 7.5 kVA - 50 kVA

61 Series Optional Wall Mounting Brackets

Single Phase 7.5 kVA - 25 kVA

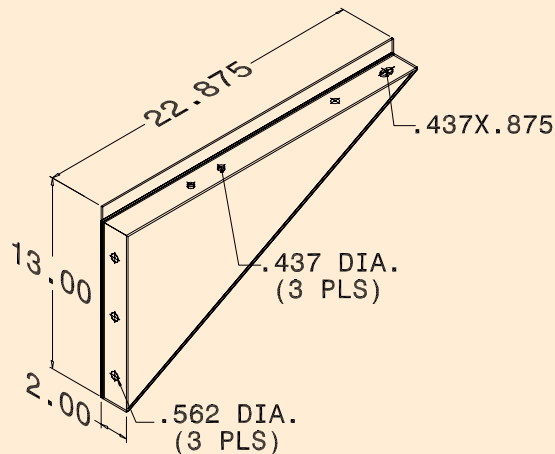

Catalog No. BR - 890

Single Phase 37.5 kVA - 50 kVA

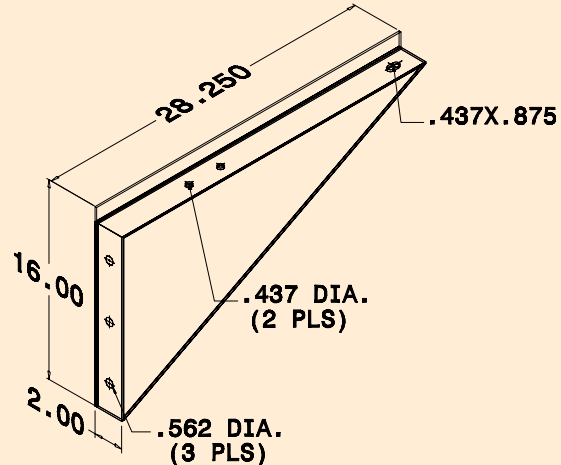

Catalog No. BR - 892



## Primary Volts 240 X 480, Secondary Volts 120 / 240

General Information				Winding Specifications				Dimensions			
kVA Cap.	Catalog Number	Hz.	Wgt. Lbs	Taps	Maximum Amps		Conn Dia. Pg. 15	Height A	Width B	Depth C	Outline Dwg.
					Pri.	Sec.					
.050	35-1005	50/60	3.3	0	.2 / .1	.4 / .2	1	6.37	3.75	3.37	1
.100	35-1010	50/60	5	0	.4 / .2	.8 / .4	1	6.37	3.75	3.37	1
.150	35-1015	50/60	7	0	.6 / .3	1.2 / .6	1	7.00	4.00	3.63	2
.250	85-1020SH	50/60	14	0	1.0 / .52	2.0 / 1.0	4	12.00	4.87	5.25	3
.500	85-1025SH	50/60	18	0	2.0 / 1.0	4.1 / 2.0	4	12.00	4.87	5.25	3
.750	85-1030SH	50/60	22	0	3.1 / 1.6	6.2 / 3.1	4	12.00	4.87	5.25	3
1.0	85-1035SH	60	29	0	4.1 / 2.0	8.3 / 4.1	4	15.25	5.75	5.87	3
1.5	85-1040SH	60	37	0	6.2 / 3.1	12.5 / 6.2	4	15.25	5.75	5.87	3
2.0	85-1045SH	60	42	0	8.3 / 4.1	16.6 / 8.3	4	15.25	5.75	5.87	3
3.0	85-1050SH	60	62	0	12.5 / 6.2	25.0 / 12.5	4	15.25	8.25	7.87	3
3.0	85-1450SH	60	62	4	12.5 / 6.2	25.0 / 12.5	2	15.25	8.25	7.87	3
5.0	85-1055SH	60	102	0	20.8 / 10.4	41.6 / 20.8	4	15.25	8.25	7.87	3
5.0	85-1455SH	60	102	4	20.8 / 10.4	41.6 / 20.8	2	15.25	8.25	7.87	3
7.5	85-1060SH	60	131	0	31 / 15.6	62 / 31	4	15.75	14.25	8.75	4
7.5	85-1460SH	60	131	4	31 / 15.6	62 / 31	2	15.75	14.25	8.75	4
10	85-1065SH	60	152	0	41 / 20	83 / 41	4	15.75	14.25	8.75	4
10	85-1465SH	60	152	4	41 / 20	83 / 41	2	15.75	14.25	8.75	4
15	85-1070SH	60	270	0	62 / 31	125 / 62	4	19.38	17.56	11.50	4
15	85-1470SH	60	270	4	62 / 31	125 / 62	2	19.38	17.56	11.50	4
25	85-1075SH	60	300	0	104 / 52	208 / 104	4	19.38	17.56	11.50	4
25	85-1475SH	60	300	4	104 / 52	208 / 104	2	19.38	17.56	11.50	4

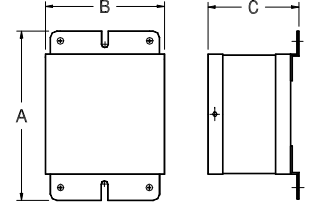

**Outline Drawing 1**  
Wall Mount - Ventilated - NEMA 1

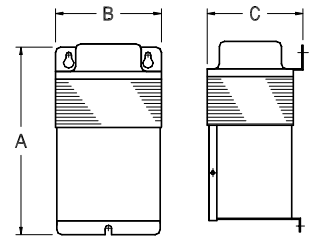

**Outline Drawing 2**  
Wall Mount - Ventilated - NEMA 3R

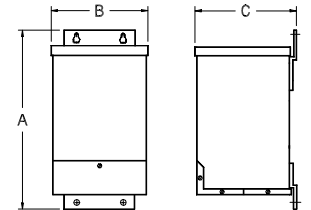

**Outline Drawing 3**  
Wall Mount - Encapsulated - NEMA 3R  
Note: 3 kVA & 5kVA 85 Series are also available in Outline Drawing 4 Configuration

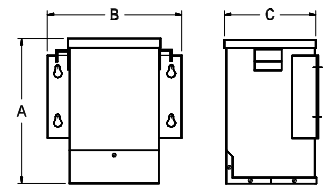

**Outline Drawing 4**  
Wall Mount - Encapsulated - NEMA 3R

## Floor Mount, Cabinet Style Enclosure

7.5	61-1460SH	60	125	4	31 / 15.6	62 / 31	2	22.00	16.00	14.00	5
10	61-1465SH	60	133	4	41 / 20	83 / 41	2	22.00	16.00	14.00	5
15	61-1470SH	60	185	4	62 / 31	125 / 62	2	23.50	18.62	16.00	5
25	61-1475SH	60	281	4	104 / 52	208 / 104	2	23.50	18.62	16.00	5
37.5	61-1680SH	60	384	6	156 / 78	312 / 156	3	32.00	27.00	26.25	5
50	61-1685SH	60	445	6	208 / 104	416 / 208	3	32.00	27.00	26.25	5
75	61-1690SH	60	663	6	312 / 156	625 / 312	3	41.00	34.00	26.75	5
100	61-1695SH	60	732	6	416 / 208	833 / 416	3	41.00	34.00	26.75	5

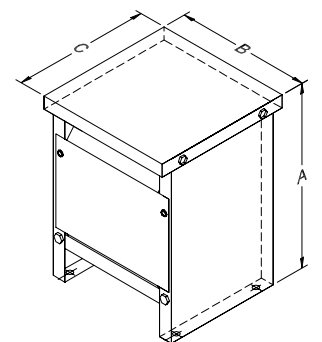

**Outline Drawing 5**  
Floor Mount - Ventilated - NEMA 3R

## Primary Volts 240 X 480, Secondary Volts 120 - Fused

General Information				Winding Specifications				Dimensions			
kVA Cap.	Catalog Number	Hz.	Wgt. Lbs	Taps	Maximum Amps		Conn Dia. Pg. 16	Height A	Width B	Depth C	Outline Dwg. Pg. 24
					Pri.	Sec.					
.100	35-2010	50/60	5	0	.4 / .2	.8	11	6.37	3.75	3.38	6
.150	35-2015	50/60	7	0	.6 / .3	1.2	11	7.00	4.00	3.63	7
.250	35-2020	50/60	11	0	1.0 / .52	2.0	11	7.50	4.50	4.00	7
.500	35-2025	50/60	20	0	2.0 / 1.0	4.1	11	9.16	5.38	4.56	7
.750	35-2030	50/60	29	0	3.1 / 1.6	6.2	11	10.75	5.50	4.75	7
1.0	80-2035	50/60	29	0	4.1 / 2.0	8.3	11	10.88	5.50	4.75	7
1.5	80-2040	50/60	37	0	6.2 / 3.1	12.5	11	10.19	6.50	5.66	7

# Single Phase - General Purpose

## Primary Volts 208, Secondary Volts 120 / 240

General Information				Winding Specifications				Dimensions			
kVA Cap.	Catalog Number	Hz.	Wgt. Lbs	Taps	Maximum Amps		Conn Dia. Pg. 15	Height A	Width B	Depth C	Outline Dwg.
					Pri.	Sec.					
.100	35-3010	50/60	5	0	.4	.8 / .4	5	6.37	3.75	3.37	1
.150	35-3015	50/60	7	0	.7	1.2 / .6	5	7.00	4.00	3.63	2
.250	85-3020SH	50/60	15	0	1.2	2.0 / 1.0	6	12.00	4.87	5.25	3
.500	85-3025SH	50/60	18	0	2.4	4.1 / 2.0	6	12.00	4.87	5.25	3
.750	85-3030SH	50/60	22	0	3.6	6.2 / 3.1	6	12.00	4.87	5.25	3
1.0	85-3035SH	60	29	0	4.8	8.3 / 4.1	6	15.25	5.75	5.87	3
1.5	85-3040SH	60	37	0	7.2	12.5 / 6.2	6	15.25	5.75	5.87	3
2.0	85-3045SH	60	44	0	9.6	16.6 / 8.3	6	15.25	5.75	5.87	3
3.0	85-3050SH	60	62	0	14.4	25.0 / 12.5	6	15.25	8.25	7.87	3
5.0	85-3055SH	60	89	0	24.0	41.6 / 20.8	6	15.25	8.25	7.87	3
7.5	85-3060SH	60	150	0	36	62 / 31	6	15.75	14.25	8.75	4
10	85-3065SH	60	165	0	48	83 / 41	6	15.75	14.25	8.75	4
15	61-3470SH	60	150	4	72	125 / 62	7	23.50	18.62	16.00	5
25	61-3475SH	60	232	4	120	208 / 104	7	23.50	18.62	16.00	5

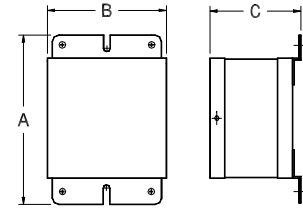

Outline Drawing 1  
Wall Mount - Ventilated - NEMA 1

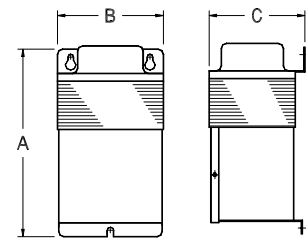

Outline Drawing 2  
Wall Mount - Ventilated - NEMA 3R

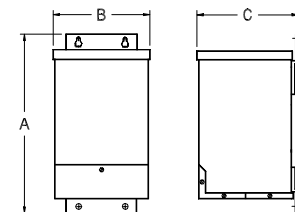

Outline Drawing 3  
Wall Mount - Encapsulated - NEMA 3R  
Note: 3 kVA & 5kVA 85 Series are also available in Outline Drawing 4 Configuration

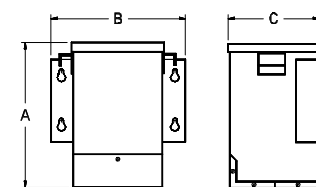

Outline Drawing 4  
Wall Mount - Encapsulated - NEMA 3R

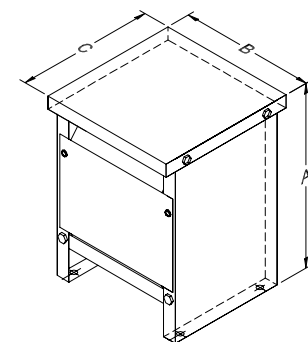

Outline Drawing 5  
Floor Mount - Ventilated - NEMA 3R

## Primary Volts 277, Secondary Volts 120 / 240

General Information				Winding Specifications				Dimensions			
kVA Cap.	Catalog Number	Hz.	Wgt. Lbs	Taps	Maximum Amps		Conn Dia. Pg. 16	Height A	Width B	Depth C	Outline Dwg.
					Pri.	Sec.					
.100	35-4010	50/60	5	0	.3	.8 / .4	8	6.37	3.75	3.37	1
.150	35-4015	50/60	7	0	.5	1.2 / .6	8	7.00	4.00	3.63	2
.250	85-4020SH	50/60	15	0	.9	2.0 / 1.0	9	12.00	4.87	5.25	3
.500	85-4025SH	50/60	18	0	1.8	4.1 / 2.0	9	12.00	4.87	5.25	3
.750	85-4030SH	50/60	22	0	2.7	6.2 / 3.1	9	12.00	4.87	5.25	3
1.0	85-4035SH	60	29	0	3.6	8.3 / 4.1	9	15.25	5.75	5.87	3
1.5	85-4040SH	60	37	0	5.4	12.5 / 6.2	9	15.25	5.75	5.87	3
2.0	85-4045SH	60	44	0	7.2	16.6 / 8.3	9	15.25	5.75	5.87	3
3.0	85-4050SH	60	62	0	10.8	25.0 / 12.5	9	15.25	8.25	7.87	3
5.0	85-4055SH	60	89	0	18	41.6 / 20.8	9	15.25	8.25	7.87	3
7.5	85-4060SH	60	150	0	27	62 / 31	9	15.75	14.25	8.75	4
10	85-4065SH	60	165	0	36	83 / 41	9	15.75	14.25	8.75	4
15	61-4470SH	60	150	4	54	125 / 62	10	23.50	18.62	16.00	5
25	61-4475SH	60	232	4	90	208 / 104	10	23.50	18.62	16.00	5

Connection Diagrams may be found on Pgs. 15 - 16

### Tap Configurations:

- 0 = No Taps
- 2 = 1 - 5% FCAN, 1 - 5% FCBN
- 4 = 2 - 2½% FCAN, 2 - 2½% FCBN
- 6 = 2 - 2½% FCAN, 4 - 2½% FCBN

Dimensions & weights may change. Consult factory for certified drawings.

## Primary Volts 600, Secondary Volts 120 / 240

General Information				Winding Specifications				Dimensions			
kVA Cap.	Catalog Number	Hz.	Wgt. Lbs	Taps	Maximum Amps		Conn Dia. Pg. 16	Height A	Width B	Depth C	Outline Dwg.
					Pri.	Sec.					
.100	35-5010	50/60	5	0	.1	.8 / .4	12	6.37	3.75	3.37	1
.150	35-5015	50/60	7	0	.2	1.2 / .6	12	7.00	4.00	3.63	2
.250	85-5020SH	50/60	15	0	.4	2.0 / 1.0	13	12	4.87	5.25	3
.500	85-5025SH	50/60	18	0	.8	4.1 / 2.0	13	12	4.87	5.25	3
.750	85-5030SH	50/60	22	0	1.2	6.2 / 3.1	13	12	4.87	5.25	3
1.0	85-5035SH	60	29	0	1.6	8.3 / 4.1	13	15.25	5.75	5.87	3
1.5	85-5040SH	60	37	0	2.5	12.5 / 6.2	13	15.25	5.75	5.87	3
2.0	85-5045SH	60	44	0	3.3	16.6 / 8.3	13	15.25	5.75	5.87	3
3.0	85-5050SH	60	62	0	5.0	25.0 / 12.5	13	15.25	8.25	7.87	3
5.0	85-5055SH	60	89	0	8.3	41.6 / 20.8	13	15.25	8.25	7.87	3
7.5	85-5060SH	60	150	0	12	62 / 31	13	15.75	14.25	8.75	4
10	85-5065SH	60	165	0	16	83 / 41	13	15.75	14.25	8.75	4
15	85-5470SH	60	150	4	25	125 / 62	14	19.38	17.56	11.50	4
25	85-5475SH	60	232	4	41.6	208 / 104	14	19.38	17.56	11.50	4
Cabinet Style											
15	61-5470SH	60	150	4	25	125 / 62	14	23.50	18.62	16.00	5
25	61-5475SH	60	232	4	41.6	208 / 104	14	23.50	18.62	16.00	5
37.5	61-5480SH	60	330	4	62	312 / 156	14	32.00	27.00	26.25	5
50	61-5485SH	60	359	4	83	416 / 208	14	32.00	27.00	26.25	5
75	61-5490SH	60	524	4	125	625 / 312	14	41.00	34.00	26.75	5
100	61-5495SH	60	648	4	166	833 / 416	14	41.00	34.00	26.75	5

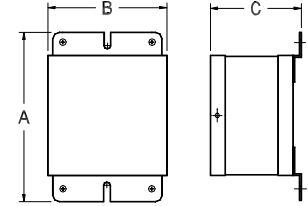

**Outline Drawing 1**  
Wall Mount - Ventilated - NEMA 1

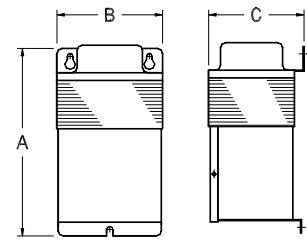

**Outline Drawing 2**  
Wall Mount - Ventilated - NEMA 3R

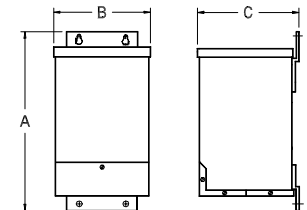

**Outline Drawing 3**  
Wall Mount - Encapsulated - NEMA 3R  
Note: 3 kVA & 5kVA 85 Series are also available in Outline Drawing 4 Configuration

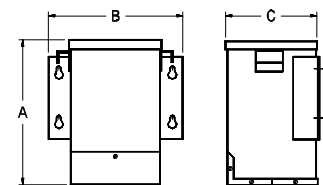

**Outline Drawing 4**  
Wall Mount - Encapsulated - NEMA 3R

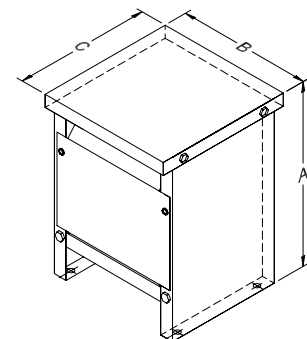

**Outline Drawing 5**  
Floor Mount - Ventilated - NEMA 3R

## Primary Volts 120 / 240, Secondary Volts 120 / 240

General Information				Winding Specifications				Dimensions			
kVA Cap.	Catalog Number	Hz.	Wgt. Lbs	Taps	Maximum Amps		Conn Dia. Pg. 17	Height A	Width B	Depth C	Outline Dwg.
					Pri.	Sec.					
.100	35-6010	50/60	5	0	.8 / .4	.8 / .4	15	6.37	3.75	3.37	1
.150	35-6015	50/60	7	0	1.2 / .6	1.2 / .6	15	7.00	4.00	3.63	2
.250	85-6020SH	50/60	15	0	2.0 / 1.0	2.0 / 1.0	16	12	4.87	5.25	3
.500	85-6025SH	50/60	18	0	4.1 / 2.0	4.1 / 2.0	16	12	4.87	5.25	3
.750	85-6030SH	50/60	22	0	6.2 / 3.1	6.2 / 3.1	16	12	4.87	5.25	3
1.0	85-6035SH	60	29	0	8.3 / 4.1	8.3 / 4.1	16	15.25	5.75	5.87	3
1.5	85-6040SH	60	37	0	12.5 / 6.2	12.5 / 6.2	16	15.25	5.75	5.87	3
2.0	85-6045SH	60	44	0	16.6 / 8.3	16.6 / 8.3	16	15.25	5.75	5.87	3
3.0	85-6050SH	60	62	0	25.0 / 12.5	25.0 / 12.5	16	15.25	8.25	7.87	3
5.0	85-6055SH	60	89	0	41.6 / 20.8	41.6 / 20.8	16	15.25	8.25	7.87	3
7.5	85-6060SH	60	150	0	62 / 31	62 / 31	16	15.75	14.25	8.75	4
10	85-6065SH	60	165	0	83 / 41	83 / 41	16	15.75	14.25	8.75	4
15	61-6470SH	60	150	4	125 / 62	125 / 62	17	23.50	18.62	16.00	5
25	61-6475SH	60	232	4	208 / 104	208 / 104	17	23.50	18.62	16.00	5

Connection Diagrams may be found on  
Pgs. 16 - 17

# Single Phase - Low Voltage

## Primary Volts 120 X 240, Secondary Volts 12 / 24

General Information				Winding Specifications				Dimensions			
kVA Cap.	Catalog Number	Hz.	Wgt. Lbs	Taps	Maximum Amps		Conn Dia. Pg. 17	Height A	Width B	Depth C	Outline Dwg.
					Pri.	Sec.					
.050	35-M005	50/60	4	0	.4 / .2	4.1 / 2.0	18	6.37	3.75	3.37	1
.100	35-M010	50/60	5	0	.8 / .4	8.3 / 4.1	18	6.37	3.75	3.37	1
.150	35-M015	50/60	7	0	1.2 / .6	12.5 / 6.2	18	7.00	3.87	3.37	2
.250	85-M020	50/60	15	0	2.0 / 1.0	20.8 / 10.4	18	12.00	4.87	5.25	3
.500	85-M025	50/60	19	0	4.1 / 2.0	41.6 / 20.8	18	12.00	4.87	5.25	3
.750	85-M030	50/60	23	0	6.2 / 3.1	62.5 / 31.2	18	12.00	4.87	5.25	3
1.0	85-M035	60	28	0	8 / 4	83 / 41	18	15.25	5.75	5.87	3
1.5	85-M040	60	39	0	12 / 6	125 / 62	18	15.25	5.75	5.87	3
2.0	85-M045	60	43	0	16 / 8	166 / 83	18	15.25	5.75	5.87	3
3.0	85-M050	60	69	0	25 / 12	250 / 125	18	15.25	8.25	7.87	3
5.0	85-M055	60	89	0	41 / 20	416 / 208	18	15.25	8.25	7.87	3

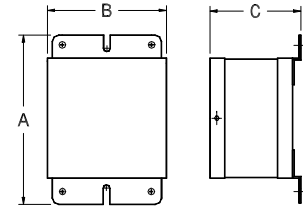

Outline Drawing 1  
Wall Mount - Ventilated - NEMA 1

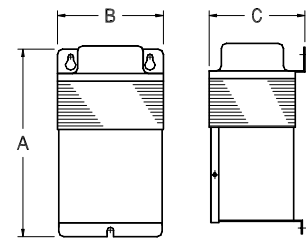

Outline Drawing 2  
Wall Mount - Ventilated - NEMA 3R

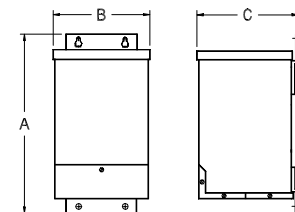

Outline Drawing 3  
Wall Mount - Encapsulated - NEMA 3R  
Note: 3 kVA & 5kVA 85 Series are also available in Outline Drawing 4 Configuration

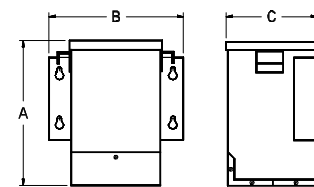

Outline Drawing 4  
Wall Mount - Encapsulated - NEMA 3R

## Primary Volts 120 X 240, Secondary Volts 16 / 32

General Information				Winding Specifications				Dimensions			
kVA Cap.	Catalog Number	Hz.	Wgt. Lbs	Taps	Maximum Amps		Conn Dia. Pg. 17	Height A	Width B	Depth C	Outline Dwg.
					Pri.	Sec.					
.050	35-Y005	50/60	4	0	.4 / .2	3.1 / 1.5	19	6.37	3.75	3.37	1
.100	35-Y010	50/60	5	0	.8 / .4	6.2 / 3.1	19	6.37	3.75	3.37	1
.150	35-Y015	50/60	7	0	1.2 / .6	9.3 / 4.6	19	7.00	4.00	3.63	2
.250	85-Y020	50/60	15	0	2.0 / 1.0	15.6 / 7.8	19	12.00	4.87	5.25	3
.500	85-Y025	50/60	19	0	4.1 / 2.0	31.2 / 15.6	19	12.00	4.87	5.25	3
.750	85-Y030	50/60	23	0	6.2 / 3.1	46.8 / 23.4	19	12.00	4.87	5.25	3
1.0	85-Y035	60	28	0	8 / 4	62 / 31	19	15.25	5.75	5.87	3
1.5	85-Y040	60	39	0	12 / 6	93 / 46	19	15.25	5.75	5.87	3
2.0	85-Y045	60	43	0	16 / 8	125 / 62	19	15.25	5.75	5.87	3
3.0	85-Y050	60	69	0	25 / 12	187 / 93	19	15.25	8.25	7.87	3
5.0	85-Y055	60	89	0	41 / 20	312 / 156	19	15.25	8.25	7.87	3

## Primary Volts 240 X 480, Secondary Volts 24 / 48

General Information				Winding Specifications				Dimensions			
kVA Cap.	Catalog Number	Hz.	Wgt. Lbs	Taps	Maximum Amps		Conn Dia. Pg. 17	Height A	Width B	Depth C	Outline Dwg.
					Pri.	Sec.					
.100	35-LM010	50/60	5	0	.4 / .2	4.1 / 2.0	20	6.37	3.75	3.37	1
.150	35-LM015	50/60	7	0	.6 / .3	6.2 / 3.1	20	7.00	4.00	3.63	2
.250	85-LM020	50/60	15	0	1.0 / .52	10.4 / 5.2	20	12.00	4.87	5.25	3
.500	85-LM025	50/60	19	0	2.0 / 1.0	20.8 / 10.4	20	12.00	4.87	5.25	3
.750	85-LM030	50/60	23	0	3.1 / 1.6	31.2 / 15.6	20	12.00	4.87	5.25	3
1.0	85-LM035	60	28	0	4 / 2	41 / 20	20	15.25	5.75	5.87	3
1.5	85-LM040	60	39	0	6 / 3	62 / 31	20	15.25	5.75	5.87	3
2.0	85-LM045	60	43	0	8 / 4	83 / 41	20	15.25	5.75	5.87	3
3.0	85-LM050	60	69	0	12 / 6	125 / 62	20	15.25	8.25	7.87	3
5.0	85-LM055	60	89	0	20 / 10	208 / 104	20	15.25	8.25	7.87	3

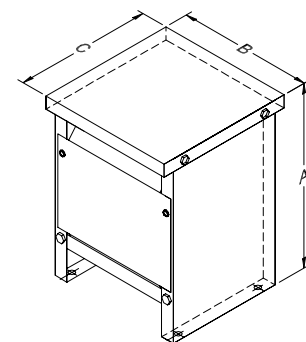

Outline Drawing 5  
Floor Mount - Ventilated - NEMA 3R

DONGAN ELECTRIC MANUFACTURING CO. • 2987 FRANKLIN • DETROIT, MI 48207  
 800.428.2626 • 313.567.8500 • FAX 313.567.8828 • www.dongan.com

## Primary Volts 240 X 480, Secondary Volts 120 / 240

General Information				Winding Specifications				Dimensions			
kVA Cap.	Catalog Number	Hz.	Wgt. Lbs	Taps	Maximum Amps		Conn Dia. Pg. 15	Height A	Width B	Depth C	Outline Dwg.
					Pri.	Sec.					
.050	35-1005	50/60	3.3	0	.2 / .1	.4 / 2	1	6.37	3.75	3.37	1
.100	35-1010	50/60	5	0	.4 / .2	.8 / 4	1	6.37	3.75	3.37	1
.150	35-1015	50/60	7	0	.6 / .3	1.2 / .6	1	7.00	4.00	3.63	2
.250	35-1020	50/60	11	0	1.0 / .52	2.0 / 1.0	1	7.50	4.63	4.00	2
.500	35-1025	50/60	20	0	2.0 / 1.0	4.1 / 2.0	1	9.25	5.50	4.75	2
.750	35-1030	50/60	28	0	3.1 / 1.6	6.2 / 3.1	1	10.88	5.50	4.75	2
1.0	80-1035	50/60	29	0	4.1 / 2.0	8.3 / 4.1	1	10.88	5.50	4.75	2
1.5	80-1040	50/60	37	0	6.2 / 3.1	12.5 / 6.2	1	10.63	6.63	5.88	2
2.0	80-1045	60	41	0	8.3 / 4.1	16.6 / 8.3	1	11.00	6.63	5.88	2
3.0	80-1050	60	53	0	12.5 / 6.2	25.0 / 12.5	1	10.88	7.69	6.88	2
5.0	80-1055	60	77	0	20.8 / 10.4	41.6 / 20.8	1	13.69	7.69	6.88	2

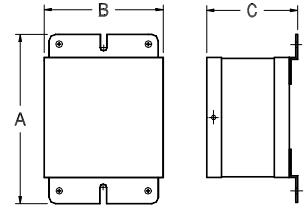

**Outline Drawing 1**  
Wall Mount - Ventilated - NEMA 1

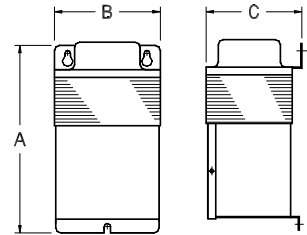

**Outline Drawing 2**  
Wall Mount - Ventilated - NEMA 3R

## Primary Volts 208, Secondary Volts 120 / 240

General Information				Winding Specifications				Dimensions			
kVA Cap.	Catalog Number	Hz.	Wgt. Lbs	Taps	Maximum Amps		Conn Dia. Pg. 15	Height A	Width B	Depth C	Outline Dwg.
					Pri.	Sec.					
.100	35-3010	50/60	5	0	.4	.8 / 4	5	6.37	3.75	3.37	1
.150	35-3015	50/60	7	0	.7	1.2 / .6	5	7.00	4.00	3.63	2
.250	35-3020	50/60	11	0	1.2	2.0 / 1.0	5	7.50	4.63	4.00	2
.500	35-3025	50/60	20	0	2.4	4.1 / 2.0	5	9.25	5.50	4.75	2
.750	35-3030	50/60	28	0	3.6	6.2 / 3.1	5	10.88	5.50	4.75	2
1.0	80-3035	50/60	29	0	4.8	8.3 / 4.1	5	10.88	5.50	4.75	2
1.5	80-3040	50/60	37	0	7.2	12.5 / 6.2	5	10.63	6.63	5.88	2

Connection Diagrams may be found on Pgs. 15 - 16

### Tap Configurations:

- 0 = No Taps
- 2 = 1 - 5% FCAN, 1 - 5% FCBN
- 4 = 2 - 2½% FCAN, 2 - 2½% FCBN
- 6 = 2 - 2½% FCAN, 4 - 2½% FCBN

Dimensions & weights may change. Consult factory for certified drawings.

## Primary Volts 277, Secondary Volts 120 / 240

General Information				Winding Specifications				Dimensions			
kVA Cap.	Catalog Number	Hz.	Wgt. Lbs	Taps	Maximum Amps		Conn Dia. Pg. 16	Height A	Width B	Depth C	Outline Dwg.
					Pri.	Sec.					
.100	35-4010	50/60	5	0	.3	.8 / 4	8	6.37	3.75	3.37	1
.150	35-4015	50/60	7	0	.5	1.2 / .6	8	7.00	4.00	3.63	2
.250	35-4020	50/60	11	0	.9	2.0 / 1.0	8	7.50	4.63	4.0	2
.500	35-4025	50/60	20	0	1.8	4.1 / 2.0	8	9.25	5.50	4.75	2
.750	35-4030	50/60	28	0	2.7	6.2 / 3.1	8	10.88	5.50	4.75	2
1.0	80-4035	50/60	29	0	3.6	8.3 / 4.1	8	10.88	5.50	4.75	2
1.5	80-4040	50/60	37	0	5.4	12.5 / 6.2	8	10.63	6.63	5.88	2



## Single Phase - General Purpose Ventilated

**Primary Volts 600,  
Secondary Volts 120 / 240**

General Information				Winding Specifications				Dimensions			
kVA Cap.	Catalog Number	Hz.	Wgt. Lbs	Taps	Maximum Amps		Conn Dia. Pg. 16	Height A	Width B	Depth C	Outline Dwg.
					Pri.	Sec.					
.100	35-5010	50/60	5	0	.1	.8 / .4	12	6.37	3.75	3.37	1
.150	35-5015	50/60	7	0	.2	1.2 / .6	12	7.00	4.00	3.63	2
.250	35-5020	50/60	11	0	.4	2.0 / 1.0	12	7.50	4.63	4.00	2
.500	35-5025	50/60	20	0	.8	4.1 / 2.0	12	9.25	5.50	4.75	2
.750	35-5030	50/60	28	0	1.2	6.2 / 3.1	12	10.88	5.50	4.75	2
1.0	80-5035	50/60	29	0	1.6	8.3 / 4.1	12	10.88	5.50	4.75	2
1.5	80-5040	50/60	37	0	2.5	12.5 / 6.2	12	10.63	6.63	5.88	2

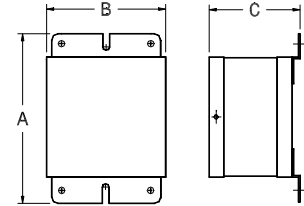

**Outline Drawing 1**  
Wall Mount - Ventilated - NEMA 1

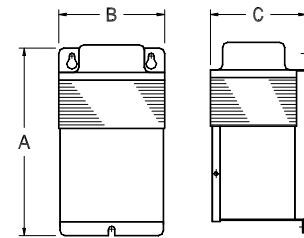

**Outline Drawing 2**  
Wall Mount - Ventilated - NEMA 3R

**Primary Volts 120 / 240,  
Secondary Volts 120 / 240**

General Information				Winding Specifications				Dimensions			
kVA Cap.	Catalog Number	Hz.	Wgt. Lbs	Taps	Maximum Amps		Conn Dia. Pg. 17	Height A	Width B	Depth C	Outline Dwg.
					Pri.	Sec.					
.100	35-6010	50/60	5	0	.8 / .4	.8 / .4	15	6.37	3.75	3.37	1
.150	35-6015	50/60	7	0	1.2 / .6	1.2 / .6	15	7.00	4.00	3.63	2
.250	35-6020	50/60	11	0	2.0 / 1.0	2.0 / 1.0	15	7.50	4.63	4.00	2
.500	35-6025	50/60	20	0	4.1 / 2.0	4.1 / 2.0	15	9.25	5.50	4.75	2
.750	35-6030	50/60	28	0	6.2 / 3.1	6.2 / 3.1	15	10.88	5.50	4.75	2
1.0	80-6035	50/60	29	0	8.3 / 4.1	8.3 / 4.1	15	10.88	5.50	4.75	2
1.5	80-6040	50/60	37	0	12.5 / 6.2	12.5 / 6.2	15	10.63	6.63	5.88	2

**Primary Volts 480,  
Secondary Volts 120 / 240,  
With 2 - 5% FCBN Taps**

General Information				Winding Specifications				Dimensions			
kVA Cap.	Catalog Number	Hz.	Wgt. Lbs	Tap Code	Maximum Amps		Conn Dia.	Height A	Width B	Depth C	Outline Dwg.
					Pri.	Sec.					
1.0	80-7235	50/60	29	*	2.0	8.3 / 4.1	See Wind. Dia. at Right	10.88	5.50	4.75	2
1.5	80-7240	50/60	37	*	3.1	12.5 / 6.2		10.63	6.63	5.88	2
2.0	80-7245	60	41	*	4.1	16.6 / 8.3		11.00	6.63	5.88	2
3.0	80-7250	60	53	*	6.2	25.0 / 12.5		10.88	7.69	6.88	2
5.0	80-7255	60	77	*	10.4	41.6 / 20.8		13.69	7.69	6.88	2

\* Tap Configuration for this series is: 2 - 5% FCBN

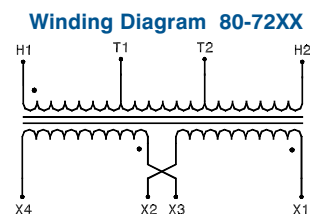

## Primary Volts 120 X 240, Secondary Volts 12 / 24

General Information				Winding Specifications			Dimensions				
kVA Cap.	Catalog Number	Hz.	Wgt. Lbs	Taps	Maximum Amps		Conn Dia. Pg. 17	Height A	Width B	Depth C	Outline Dwg.
					Pri.	Sec.					
.050	35-M005	50/60	5	0	.4 / .2	4.1 / 2.0	18	6.37	3.75	3.37	1
.100	35-M010	50/60	8	0	.8 / .4	8.3 / 4.1	18	6.37	3.75	3.37	1
.150	35-M015	50/60	8	0	1.2 / .6	12.5 / 6.2	18	7.00	4.00	3.63	2
.250	35-M020	50/60	11	0	2.0 / 1.0	20.8 / 10.4	18	7.50	4.63	4.00	2
.500	35-M025	50/60	20	0	4.1 / 2.0	41.6 / 20.8	18	9.28	5.50	4.75	2
.750	35-M030	50/60	28	0	6.2 / 3.1	62.5 / 31.2	18	10.88	5.50	4.75	2
1.0	80-M035	50/60	29	0	8 / 4	83 / 41	18	10.88	5.50	4.75	2
1.5	80-M040	50/60	37	0	12 / 6	125 / 62	18	10.63	6.63	5.88	2
2.0	80-M045	60	42	0	16 / 8	166 / 83	18	11.00	6.63	5.88	2
3.0	80-M050	60	58	0	25 / 12	250 / 125	18	16.38	7.69	6.88	2
5.0	80-M055	60	82	0	41 / 20	416 / 208	18	18.50	7.69	6.88	2

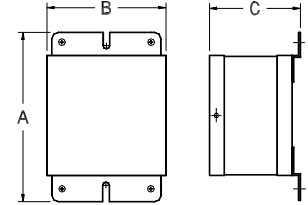

**Outline Drawing 1**  
Wall Mount - Ventilated - NEMA 1

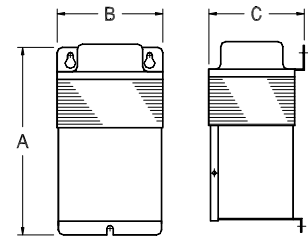

**Outline Drawing 2**  
Wall Mount - Ventilated - NEMA 3R

## Primary Volts 120 X 240, Secondary Volts 16 / 32

General Information				Winding Specifications			Dimensions				
kVA Cap.	Catalog Number	Hz.	Wgt. Lbs	Taps	Maximum Amps		Conn Dia. Pg. 17	Height A	Width B	Depth C	Outline Dwg.
					Pri.	Sec.					
.050	35-Y005	50/60	5	0	.4 / .2	3.1 / 1.5	19	6.37	3.75	3.37	1
.100	35-Y010	50/60	8	0	.8 / .4	6.2 / 3.1	19	6.37	3.75	3.37	1
.150	35-Y015	50/60	8	0	1.2 / .6	9.3 / 4.6	19	7.00	4.00	3.63	2
.250	35-Y020	50/60	11	0	2.0 / 1.0	15.6 / 7.8	19	7.50	4.63	4.00	2
.500	35-Y025	50/60	20	0	4.1 / 2.0	31.2 / 15.6	19	9.25	5.50	4.75	2
.750	35-Y030	50/60	28	0	6.2 / 3.1	46.8 / 23.4	19	10.88	5.50	4.75	2
1.0	80-Y035	50/60	29	0	8 / 4	62 / 31	19	10.88	5.50	4.75	2
1.5	80-Y040	50/60	37	0	12 / 6	93 / 46	19	10.63	6.63	5.88	2
2.0	80-Y045	60	42	0	16 / 8	125 / 62	19	11.00	6.63	5.88	2
3.0	80-Y050	60	58	0	25 / 12	187 / 93	19	16.38	7.69	6.88	2
5.0	80-Y055	60	82	0	41 / 20	312 / 156	19	18.50	7.69	6.88	2

Connection Diagrams may be found on Pgs. 17

### Tap Configurations:

- 0 = No Taps
- 2 = 1 - 5% FCAN, 1 - 5% FCBN
- 4 = 2 - 2½% FCAN, 2 - 2½% FCBN
- 6 = 2 - 2½% FCAN, 4 - 2½% FCBN

Dimensions & weights may change. Consult factory for certified drawings.

## Primary Volts 240 X 480, Secondary Volts 24 / 48

General Information				Windings Specifications			Dimensions				
kVA Cap.	Catalog Number	Hz.	Wgt. Lbs	Taps	Maximum Amps		Conn Dia. Pg. 17	Height A	Width B	Depth C	Outline Dwg.
					Pri.	Sec.					
.100	35-LM010	50/60	8	0	.4 / .2	4.1 / 2.0	20	6.37	3.75	3.37	1
.150	35-LM015	50/60	8	0	.6 / .3	6.2 / 3.1	20	7.00	4.00	3.63	2
.250	35-LM020	50/60	11	0	1.0 / .52	10.4 / 5.2	20	7.50	4.63	4.00	2
.500	35-LM025	50/60	20	0	2.0 / 1.0	20.8 / 10.4	20	9.25	5.50	4.75	2
.750	35-LM030	50/60	28	0	3.1 / 1.6	31.2 / 15.6	20	10.88	5.50	4.75	2
1.0	80-LM035	50/60	29	0	4 / 2	41 / 20	20	10.88	5.50	4.75	2
1.5	80-LM040	50/60	37	0	6 / 3	62 / 31	20	10.63	6.63	5.88	2
2.0	80-LM045	60	42	0	8 / 4	83 / 41	20	11.00	6.63	5.88	2
3.0	80-LM050	60	58	0	12 / 6	125 / 62	20	16.38	7.69	6.88	2
5.0	80-LM055	60	82	0	20 / 10	208 / 104	20	18.50	7.69	6.88	2

# Single Phase Connection Diagrams

Dia. 1 Catalog Series 35-10XX & 80-10XX			
Tap Arrangement	None		
% High Voltage	High Voltage 240 X 480	Inter-Connect	Connect High Voltage Lines To
100	240	H1 To H3 H2 To H4	H1H3 & H2H4
100	480	H2 To H3	H1 & H4
% Low Voltage	Low Voltage 120 / 240	Inter-Connect	Connect Low Voltage Lines To
100	120	X1 To X3 X2 To X4	X1X3 & X2X4
100	120 / 240	X2 To X3	X1 & X2X3 & X4
100	240	X2 To X3	X1 & X4

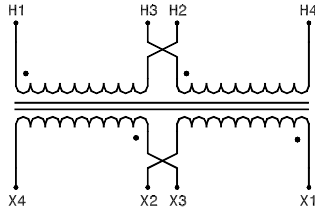

Dia. 2 Catalog Series 85-14XXSH & 61-14XXSH				
Tap Arrangement	2 - 2½ FCAN (Full Capacity Above Normal) 2 - 2½ FCBN (Full Capacity Below Normal)			
% High Voltage	High Voltage 240 X 480	Inter-Connect	Connect High Voltage Lines To	
105	252	H1 To 2 H2 To 1	H1 & H2	
100	240	H1 To 4 H2 To 3		
95	228	H1 To 6 H2 To 5		
105	504	1 To 2		
102.5	492	2 To 3		
100	480	3 To 4		
97.5	468	4 To 5		
95	456	5 To 6		
% Low Voltage	Low Voltage 120 / 240	Inter-Connect		Connect Low Voltage Lines To
100	120	X1 To X3 X2 To X4		X1X3 & X2X4
100	120 / 240	X2 To X3	X1 & X2X3 & X4	
100	240	X2 To X3	X1 & X4	

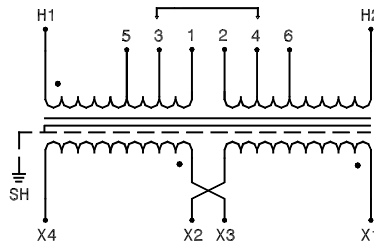

Dia. 3 Catalog Series 61-16XXSH			
Tap Arrangement	2 - 2½ FCAN (Full Capacity Above Normal) 4 - 2½ FCBN (Full Capacity Below Normal)		
% High Voltage	High Voltage 240 X 480	Inter-Connect	Connect High Voltage Lines To
105	252	H1 To 2 H2 To 1	H1 & H2
100	240	H1 To 4 H2 To 3	
95	228	H1 To 6 H2 To 5	
90	216	H1 To 8 H2 To 7	
105	504	1 To 2	
102.5	492	2 To 3	
100	480	3 To 4	
97.5	468	4 To 5	
95	456	5 To 6	
92.5	444	6 To 7	
90	432	7 To 8	
% Low Voltage	Low Voltage 120 / 240	Inter-Connect	Connect Low Voltage Lines To
100	120	X1 To X3 X2 To X4	X1X3 & X2X4
100	120 / 240	X2 To X3	X1 & X2X3 & X4
100	240	X2 To X3	X1 & X4

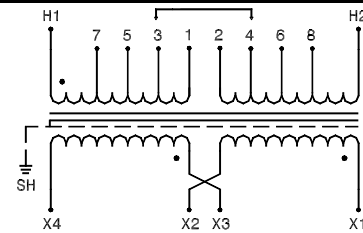

Dia. 4 Catalog Series 85-10XXSH			
Tap Arrangement	None		
% High Voltage	High Voltage 240 X 480	Inter-Connect	Connect High Voltage Lines To
100	240	H1 To H3 H2 To H4	H1H3 & H2H4
100	480	H2 To H3	H1 & H4
% Low Voltage	Low Voltage 120 / 240	Inter-Connect	Connect Low Voltage Lines To
100	120	X1 To X3 X2 To X4	X1X3 & X2X4
100	120 / 240	X2 To X3	X1 & X2X3 & X4
100	240	X2 To X3	X1 & X4

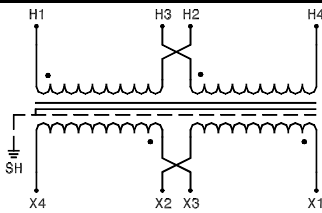

Dia. 5 Catalog Series 35-30XX & 80-30XX			
Tap Arrangement	None		
% High Voltage	High Voltage 208	Inter-Connect	Connect High Voltage Lines To
100	208	--	H1 & H2
% Low Voltage	Low Voltage 120 / 240	Inter-Connect	Connect Low Voltage Lines To
100	120	X1 To X3 X2 To X4	X1X3 & X2X4
100	120 / 240	X2 To X3	X1 & X2X3 & X4
100	240	X2 To X3	X1 & X4

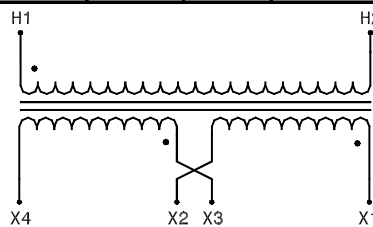

Dia. 6 Catalog Series 85-30XXSH			
Tap Arrangement	None		
% High Voltage	High Voltage 208	Inter-Connect	Connect High Voltage Lines To
100	208	--	H1 & H2
% Low Voltage	Low Voltage 120 / 240	Inter-Connect	Connect Low Voltage Lines To
100	120	X1 To X3 X2 To X4	X1X3 & X2X4
100	120 / 240	X2 To X3	X1 & X2X3 & X4
100	240	X2 To X3	X1 & X4

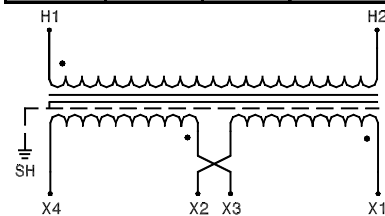

Dia. 7 Catalog Series 61-34XXSH			
Tap Arrangement	2-2½ % FCAN ( Full Capacity Above Normal) 2-2½ % FCBN ( Full Capacity Below Normal)		
% High Voltage	High Voltage 208	Inter-Connect	Connect High Voltage Lines To
105	218	1 To 2	H1 & H2
102.5	213	2 To 3	
100	208	3 To 4	
97.5	203	4 To 5	
95	198	5 To 6	
% Low Voltage	Low Voltage 120 / 240	Inter-Connect	
100	120	X1 To X3 X2 To X4	X1X3 & X2X4
100	120 / 240	X2 To X3	X1 & X2X3 & X4
100	240	X2 To X3	X1 & X4

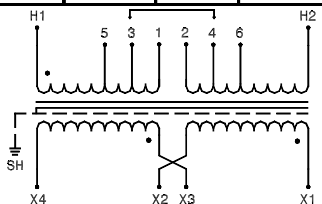

DONGAN ELECTRIC MANUFACTURING CO. • 2987 FRANKLIN • DETROIT, MI 48207  
 800.428.2626 • 313.567.8500 • FAX 313.567.8828 • www.dongan.com

# Single Phase Connection Diagrams

DONGAN ELECTRIC MANUFACTURING CO. • 2987 FRANKLIN • DETROIT, MI 48207  
 800.428.2626 • 313.567.8500 • FAX 313.567.8828 • www.dongan.com

Dia. 8 Catalog Series 35-40XX & 80-40XX			
Tap Arrangement	None		
% High Voltage	High Voltage 277	Inter-Connect	Connect High Voltage Lines To
100	277	--	H1 & H2
% Low Voltage	Low Voltage 120 / 240	Inter-Connect	Connect Low Voltage Lines To
100	120	X1 To X3 X2 To X4	X1X3 & X2X4
100	120 / 240	X2 To X3	X1 & X2X3 & X4
100	240	X2 To X3	X1 & X4

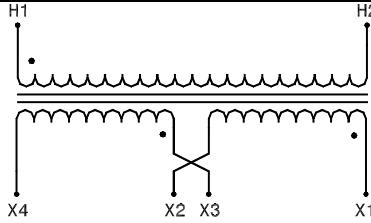

Dia. 9 Catalog Series 85-40XXSH			
Tap Arrangement	None		
% High Voltage	High Voltage 277	Inter-Connect	Connect High Voltage Lines To
100	277	--	H1 & H2
% Low Voltage	Low Voltage 120 / 240	Inter-Connect	Connect Low Voltage Lines To
100	120	X1 To X3 X2 To X4	X1X3 & X2X4
100	120 / 240	X2 To X3	X1 & X2X3 & X4
100	240	X2 To X3	X1 & X4

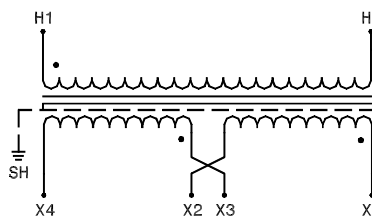

Dia. 10 Catalog Series 61-44XXSH			
Tap Arrangement	2-2½ % FCAN Full Capacity Above Normal) 2-2½ % FCBN Full Capacity Below Normal)		
% High Voltage	High Voltage 277	Inter-Connect	Connect High Voltage Lines To
105	291	1 To 2	H1 & H2
102.5	284	2 To 3	
100	277	3 To 4	
97.5	270	4 To 5	
95	263	5 To 6	
% Low Voltage	Low Voltage 120 / 240	Inter-Connect	
100	120	X1 To X3 X2 To X4	X1X3 & X2X4
100	120 / 240	X2 To X3	X1 & X2X3 & X4
100	240	X2 To X3	X1 & X4

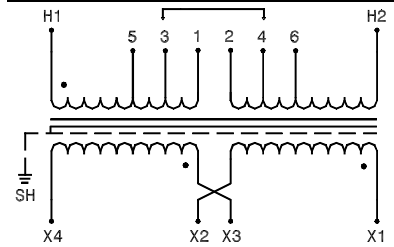

Dia. 11 Catalog Series 35-20XX & 80-20XX			
Tap Arrangement	None		
% High Voltage	High Voltage 240 X 480	Inter-Connect	Connect High Voltage Lines To
100	240	H1 To H3 H2 To H4	H1H3 & H2H4
100	480	H2 To H3	H1 & H4
% Low Voltage	Low Voltage 120 Fused	Inter-Connect	Connect Low Voltage Lines To
100	120	-	X1 & X2

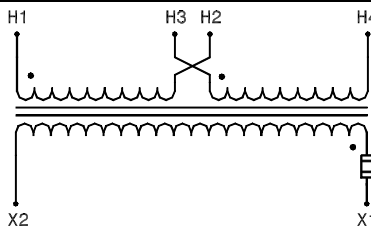

Dia. 12 Catalog Series 35-50XX & 80-50XX			
Tap Arrangement	None		
% High Voltage	High Voltage 600	Inter-Connect	Connect High Voltage Lines To
100	600	--	H1 & H2
% Low Voltage	Low Voltage 120 / 240	Inter-Connect	Connect Low Voltage Lines To
100	120	X1 To X3 X2 To X4	X1X3 & X2X4
100	120 / 240	X2 To X3	X1 & X2X3 & X4
100	240	X2 To X3	X1 & X4

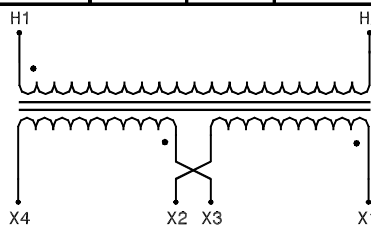

Dia. 13 Catalog Series 85-50XXSH			
Tap Arrangement	None		
% High Voltage	High Voltage 600	Inter-Connect	Connect High Voltage Lines To
100	600	--	H1 & H2
% Low Voltage	Low Voltage 120 / 240	Inter-Connect	Connect Low Voltage Lines To
100	120	X1 To X3 X2 To X4	X1X3 & X2X4
100	120 / 240	X2 To X3	X1 & X2X3 & X4
100	240	X2 To X3	X1 & X4

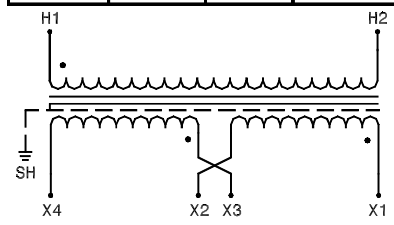

Dia. 14 Catalog Series 61-54XXSH			
Tap Arrangement	2-2½ % FCAN Full Capacity Above Normal) 2-2½ % FCBN Full Capacity Below Normal)		
% High Voltage	High Voltage 600	Inter-Connect	Connect High Voltage Lines To
105	630	1 To 2	H1 & H2
102.5	615	2 To 3	
100	600	3 To 4	
97.5	585	4 To 5	
95	570	5 To 6	
% Low Voltage	Low Voltage 120 / 240	Inter-Connect	
100	120	X1 To X3 X2 To X4	X1X3 & X2X4
100	120 / 240	X2 To X3	X1 & X2X3 & X4
100	240	X2 To X3	X1 & X4

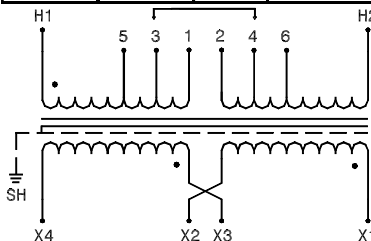

# Single Phase Connection Diagrams

Dia. 15 Catalog Series 35-60XX & 80-60XX				
Tap Arrangement	None			
% High Voltage	High Voltage 120 X 240	Inter-Connect	Connect High Voltage Lines To	
100	120	H1 To H3 H2 To H4	H1H3 & H2H4	
100	240	H2 To H3	H1 & H4	
% Low Voltage	Low Voltage 120 / 240	Inter-Connect	Connect Low Voltage Lines To	
100	120	X1 To X3 X2 To X4	X1X3 & X2X4	
100	120 / 240	X2 To X3	X1 & X2X3 & X4	
100	240	X2 To X3	X1 & X4	

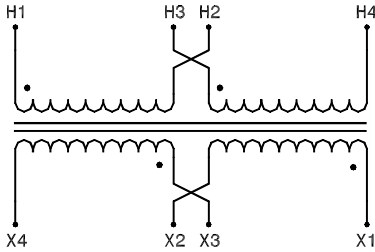

Dia. 16 Catalog Series 85-60XXSH				
Tap Arrangement	None			
% High Voltage	High Voltage 120 X 240	Inter-Connect	Connect High Voltage Lines To	
100	120	H1 To H3 H2 To H4	H1H3 & H2H4	
100	240	H2 To H3	H1 & H4	
% Low Voltage	Low Voltage 120 / 240	Inter-Connect	Connect Low Voltage Lines To	
100	120	X1 To X3 X2 To X4	X1X3 & X2X4	
100	120 / 240	X2 To X3	X1 & X2X3 & X4	
100	240	X2 To X3	X1 & X4	

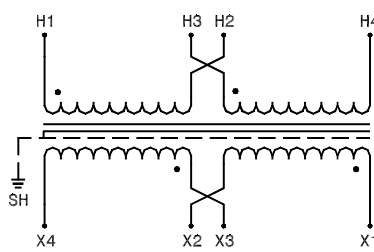

Dia. 17 Catalog Series 61-64XXSH				
Tap Arrangement	2 - 2½ FCAN (Full Capacity Above Normal) 2 - 2½ FCBN (Full Capacity Below Normal)			
% High Voltage	High Voltage 120 X 240	Inter-Connect	Connect High Voltage Lines To	
105	126	H1 To 2 H2 To 1	H1 & H2	
100	120	H1 To 4 H2 To 3		
95	114	H1 To 6 H2 To 5		
105	252	1 To 2		
102.5	246	2 To 3		
100	240	3 To 4		
97.5	234	4 To 5		
95	228	5 To 6		
% Low Voltage	Low Voltage 120 / 240	Inter-Connect	Connect Low Voltage Lines To	
100	120	X1 To X3 X2 To X4	X1X3 & X2X4	
100	120 / 240	X2 To X3	X1 & X2X3 & X4	
100	240	X2 To X3	X1 & X4	

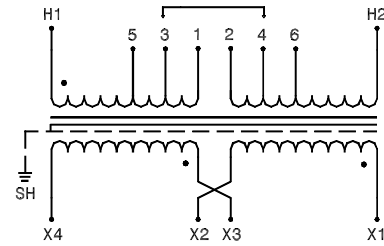

Dia. 18 Catalog Series 35-M0XX & 80-M0XX 85-M0XX				
Tap Arrangement	No Taps			
% High Voltage	High Voltage 120 X 240	Inter-Connect	Connect High Voltage Lines To	
100	120	H1 To H3 H2 To H4	H1H3 & H2H4	
100	240	H2 To H3	H1 & H4	
% Low Voltage	Low Voltage 12 / 24	Inter-Connect	Connect Low Voltage Lines To	
100	12	X1 To X3 X2 To X4	X1X3 & X2X4	
100	12 / 24	X2 To X3	X1 & X2X3 & X4	
100	24	X2 To X3	X1 & X4	

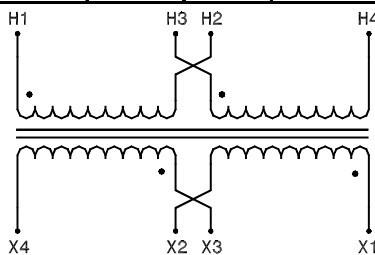

Dia. 19 Catalog Series 35-Y0XX & 80-Y0XX 85-Y0XX				
Tap Arrangement	No Taps			
% High Voltage	High Voltage 120 X 240	Inter-Connect	Connect High Voltage Lines To	
100	120	H1 To H3 H2 To H4	H1H3 & H2H4	
100	240	H2 To H3	H1 & H4	
% Low Voltage	Low Voltage 16 / 32	Inter-Connect	Connect Low Voltage Lines To	
100	16	X1 To X3 X2 To X4	X1X3 & X2X4	
100	16 / 32	X2 To X3	X1 & X2X3 & X4	
100	32	X2 To X3	X1 & X4	

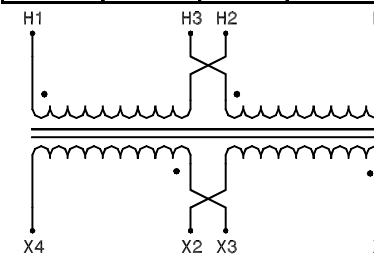

Dia. 20 Catalog Series 35-LM0XX & 80-LM0XX 85-LM0XX				
Tap Arrangement	No Taps			
% High Voltage	High Voltage 240 X 480	Inter-Connect	Connect High Voltage Lines To	
100	240	H1 To H3 H2 To H4	H1H3 & H2H4	
100	480	H2 To H3	H1 & H4	
% Low Voltage	Low Voltage 24 / 48	Inter-Connect	Connect Low Voltage Lines To	
100	24	X1 To X3 X2 To X4	X1X3 & X2X4	
100	24 / 48	X2 To X3	X1 & X2X3 & X4	
100	48	X2 To X3	X1 & X4	

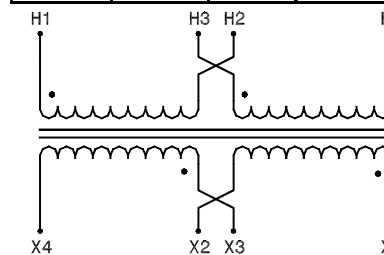

DONGAN ELECTRIC MANUFACTURING CO. • 2987 FRANKLIN • DETROIT, MI 48207  
 800.428.2626 • 313.567.8500 • FAX 313.567.8828 • www.dongan.com





## Series ES-11 CE Marked Single Phase Transformers

DONGAN ELECTRIC MANUFACTURING CO. • 2987 FRANKLIN • DETROIT, MI 48207  
 800.428.2626 • 313.567.8500 • FAX 313.567.8828 • www.dongan.com

Series ES Single Phase Encapsulated Transformers are designed to comply with Domestic, North American, and European Union electrical and testing standards. Series ES are UL and Canadian UL Listed by Underwriters Labs. In addition, Series ES are CE Marked, and licensed by the German testing agency TÜV Rheinland under License Number R 9679035.01.

Series ES transformers are the answer to your export needs. With the voltage combinations listed below, and built in approvals, the ES Series provide no-nonsense solutions for equipment destined for the European Community of nations.

Under EC guidelines, connecting transformers to line and load require finger safe connections. While other manufacturers provide leads, Dongan provides finger safe terminals on all ES-11 transformers. This feature eliminates the necessity of a difficult, labor intensive installation of terminals in the wiring compartment by the end user.

The voltage combinations offered represent some of the most universally used. However, any combination of primary and secondary incorporating voltages of 600 volts and below is available on a short lead time, special order basis. In addition, capacities up to 25 kVA and special temperature rise configurations can be

furnished. Please consult your distributor, Dongan Representative, or the factory for special ES Series transformer requirements.

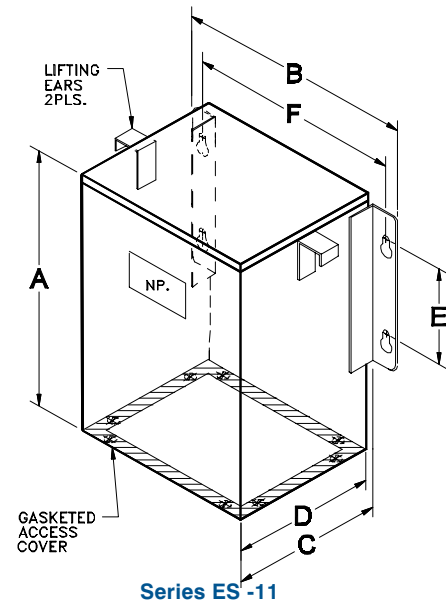

General Information									
Pri. Volts	380/400/416/440	220/380/400/416	Dimensions (inches)						Weight (lbs)
Sec. Volts	460/480/575	120/240	A	B	C	Mounting			
kVA Cap.	Catalog Number	Catalog Number				D	E	F	
.250	ES-11130.326	ES-11130.359	10.50	10.00	6.62	6.12	4.00	8.50	35
.500	ES-11170.326	ES-11170.359	10.50	10.00	6.62	6.12	4.00	8.50	45
.750	ES-11190.326	ES-11190.359	10.50	10.00	6.62	6.12	4.00	8.50	55
1.0	ES-11200.326	ES-11200.359	12.00	10.81	7.19	6.69	6.00	9.13	75
1.5	ES-11210.326	ES-11210.359	14.00	14.00	9.25	8.75	8.00	12.00	90
2.0	ES-11230.326	ES-11230.359	14.00	14.00	9.25	8.75	8.00	12.00	110
3.0	ES-11250.326	ES-11250.359	14.00	14.00	9.25	8.75	8.00	12.00	120
5.0	ES-11300.326	ES-11300.359	14.00	14.38	10.00	9.50	8.00	12.38	150
7.5	ES-11330.326	ES-11330.359	15.00	18.00	12.50	12.00	8.00	16.00	165
10.0	ES-11360.326	ES-11360.359	15.00	18.00	12.50	12.00	8.00	16.00	190
15.0	ES-11380.326	ES-11380.359	15.00	18.00	12.50	12.00	8.00	16.00	270
25.0	ES-11410.326	ES-11410.359	18.00	21.00	10.50	10.00	8.00	19.00	350

## Series ES-11 CE Marked Single Phase Transformers

### Features

- CE Marked
- TÜV Rheinland Licensed, R 9679035.01
- UL Listed, File E3210.
- CSA Listed thru UL, File E3210
- NEMA 12, IP54 enclosure.
- All copper windings.
- IEC type finger safe terminals.
- 200°C (H) Insulation System.
- 50/60 Hertz.
- Class 1, general use, isolating transformer.
- All Series ES are provided with an electrostatic shield (earth metal screen).
- All Series ES are provided with a color coded protective earth (PE) terminal.
- Consult factory for desired voltage combinations and KVA sizes not listed.

#### Agency Compliance



#### Series ES Three Phase and Industrial Control Transformers

Please see Series ES CE Marked Three Phase on pages 36 - 37 and Industrial Control transformers on pages 82 - 83 of this catalog. A Declaration of Conformity is available by contacting your Dongan Representative or the factory Customer Service Department.

Dimensions & weights may change. Consult factory for certified drawings.

Suffix .326			
Primary Connections		Secondary Connections	
Pri. Voltage	Connect Incoming Lines To:	Sec. Voltage	Connect Load Lines To:
380	H1 & H3	110	X1 & X3
400	H1 & H3	115	X1 & X3
416	H1 & H4	115	X1 & X4
440	H1 & H4	120	X1 & X4
460	H1 & H4	115	X1 & X3
480	H1 & H4	120	X1 & X3
575	H1 & H5	120	X1 & X4

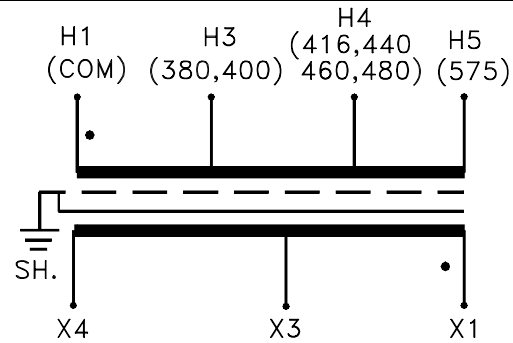

Suffix .359				
Primary Connections		Secondary Connections		
Pri. Voltage	Connect Incoming Lines To:	Sec. Voltage	Interconnect	Connect Load Lines To:
220	H1 & H3	120	X1 to X3 X2 to X4	X1 & X4
380	H1 & H4	240	X2 to X3	X1 & X4
400	H1 & H5	120/240	X2 to X3	X1 & X2X3 & X4
416	H1 & H6			

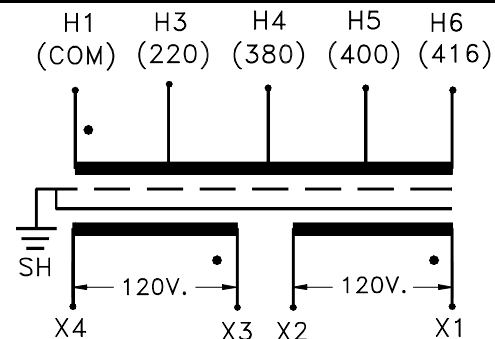

## Series 33 - Control Transformers

DONGAN ELECTRIC MANUFACTURING CO. • 2987 FRANKLIN • DETROIT, MI 48207  
 800.428.2626 • 313.567.8500 • FAX 313.567.8828 • www.dongan.com

Series 33 Control Transformers are designed with a NEMA 1, indoor type enclosure and are fitted with 8" leads exiting through a 1/2" chase nipple. Dual mounting provisions are provided for both foot mount or direct knockout mount in point of use applications. This unique mounting feature conveniently locates all leads within enclosures or handy boxes.

The 33 Series Transformers are normal reactance, isolation type designs. Typical applications include voltage reduction for solenoids, magnetic switches, control valves, as well as many other HVAC applications.

### Features

- **UL Listed, File E3210.**
- **CSA Certified, LR 560.**
- NEMA 1, indoor enclosure.
- Available primary voltages include 480, 277, 240, 208, 120, 50 / 60 Hertz.
- Special order voltages include 600, 380, 115, 12, and 6 volts.
- Available with manually resettable circuit breakers.
- Consult factory for desired voltage combinations and VA sizes not listed.
- Dual mounting capability.

General Information			Capacity		Dimensions					
kVA Cap.	Catalog Number	Wgt. Lbs	Maximum Amps		Height A	Width B	Depth C	Mounting		Slot Size F
			Pri.	Sec.				D	E	
<i>Primary 240 Volts, Secondary Volts 120, 50 / 60 Hz</i>										
.050	<b>33-050-H</b>	2.7	.20	.41	3.19	3.00	2.50	1.69	2.50	.188 x .344
.100	<b>33-100-H</b>	4	.41	.83	3.63	3.38	2.81	2.13	2.50	.188 x .375
<i>Primary Volts, 240 x 480, Secondary Volts 24, 50 / 60 Hz</i>										
.050	<b>33-050-HLK</b>	2.7	.20 / .10	2.08	3.19	3.00	2.50	1.69	2.50	.188 x .344
.100	<b>33-100-HLK</b>	4	.41 / .21	4.16	3.63	3.38	2.81	2.13	2.50	.188 x .375
<i>Primary Volts 120, Secondary 24, 50 / 60 Hz</i>										
.050	<b>33-050-K</b>	2.7	.41	2.08	3.19	3.00	2.50	1.69	2.50	.188 x .344
.100	<b>33-100-K</b>	4	.83	4.16	3.63	3.38	2.81	2.13	2.50	.188 x .375
<i>Primary Volts 240 x 480, Secondary Volts 120, 50 / 60 Hz</i>										
.050	<b>33-050-PM</b>	2.7	.20 / .10	.41	3.19	3.00	2.50	1.69	2.50	.188 x .344
.100	<b>33-100-PM</b>	4	.41 / .21	.83	3.63	3.38	2.81	2.13	2.50	.188 x .375
.150	<b>33-150-PM</b>	6	.62 / .31	1.25	4.00	3.75	3.13	2.38	3.25	.219 x .375
.250	<b>33-250-PM</b>	9	1.0 / .52	2.08	4.25	3.75	4.500	3.125	3.250	.219 x .438
<i>Primary Volts 208, Secondary Volts, 120, 50 / 60 Hz</i>										
.050	<b>33-050-17</b>	2.7	.24	.41	3.19	3.00	2.50	1.69	2.50	.188 x .344
.100	<b>33-100-17</b>	4	.48	.83	3.63	3.38	2.81	2.13	2.50	.188 x .375
<i>Primary Volts 208, Secondary Volts 24, 50 / 60 Hz</i>										
.050	<b>33-050-18</b>	2.7	.24	2.08	3.19	3.00	2.50	1.69	2.50	.188 x .344
.100	<b>33-100-18</b>	4	.48	4.16	3.63	3.38	2.81	2.13	2.50	.188 x .375
<i>Primary Volts 277, Secondary Volts 24, 50 / 60 Hz</i>										
.050	<b>33-050-26</b>	2.7	.18	2.08	3.19	3.00	2.50	1.69	2.50	.188 x .344
.100	<b>33-100-26</b>	4	.36	4.16	3.63	3.38	2.81	2.13	2.50	.188 x .375
<i>Primary Volts 277, Secondary Volts 120, 50 / 60 Hz</i>										
.050	<b>33-050-82</b>	2.7	.18	.41	3.19	3.00	2.50	1.69	2.50	.188 x .344
.100	<b>33-100-82</b>	4	.36	.83	3.63	3.38	2.81	2.13	2.50	.188 x .375

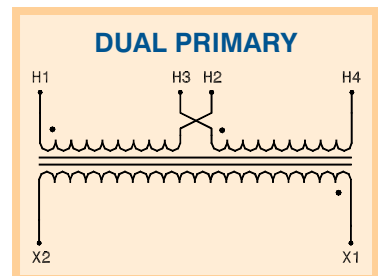
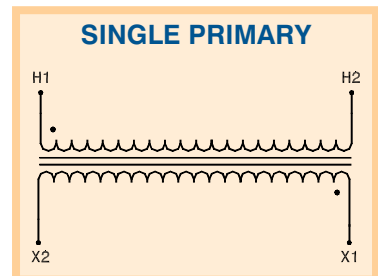
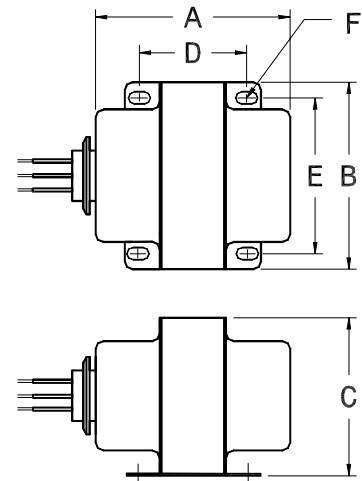

Dimensions & weights may change.  
 Consult factory for certified drawings.

## Series 36 - Signaling

Series 36 Signaling Transformers are designed to operate a wide variety of low voltage devices including complete signaling systems, AC horns and bells, and low voltage relays and controls. All 36 Series are supplied with a spacious wiring compartment and double knockouts for ease of installation.

Other low voltage transformers may be found in the 33 Series and in the General Purpose Type M, Type Y and Type LM Series.

## Features

- **UL Listed, File E3210.**
- **CSA Certified, LR 560.**
- NEMA 1 indoor enclosure.
- VA Capacity range from 50 VA to 1000 VA.
- Available primary voltages include 120, 240, and 480.
- 60 Hertz.
- Multiple secondary voltages of 4-8-12-16-20-24.
- Primary and secondary leads are partitioned in separate wiring compartments.
- Consult factory for desired voltage combinations and VA sizes not listed.

General Information			Capacity		Dimensions (inches)				
kVA Cap.*	Catalog Number	Wgt. Lbs	Maximum Amps		Height A	Width B	Depth C	Mounting	
			Pri.	Sec.				D	E
<i>Primary Volts 120, Secondary Volts 4-8-12-16-20-24, 60 Hz</i>									
.050	<b>36-05-A</b>	4	.41	2.08	6.31	3.63	3.37	5.56	2.50
.100	<b>36-10-A</b>	6	.83	4.16	7.12	4.06	3.50	6.44	2.50
.250	<b>36-25-A</b>	9	2.08	10.4	8.00	5.00	4.13	7.25	2.50
.500	<b>36-50-A</b>	16	4.16	20.8	11.50	5.88	4.88	10.50	3.81
.750	<b>36-75-A</b>	21	6.25	31.2	12.38	5.88	4.88	11.25	3.81
1.0	<b>36-100-A</b>	29	8.33	41.6	13.63	5.88	4.88	12.50	3.81
<i>Primary Volts 240, Secondary Volts 4-8-12-16-20-24, 60 Hz</i>									
.050	<b>36-05-C</b>	4	.20	2.08	6.31	3.63	3.37	5.56	2.50
.100	<b>36-10-C</b>	6	.41	4.16	7.12	4.06	3.50	6.44	2.50
.250	<b>36-25-C</b>	9	1.0	10.4	8.00	5.00	4.13	7.25	2.50
.500	<b>36-50-C</b>	16	2.08	20.8	11.50	5.88	4.88	10.50	3.81
.750	<b>36-75-C</b>	21	3.13	31.2	12.38	5.88	4.88	11.25	3.81
1.0	<b>36-100-C</b>	29	4.16	41.6	13.63	5.88	4.88	12.50	3.81
<i>Primary Volts 480, Secondary Volts 4-8-12-16-20-24, 60 Hz</i>									
.050	<b>36-05-N</b>	4	.10	2.08	6.31	3.63	3.37	5.56	2.50
.100	<b>36-10-N</b>	6	.20	4.16	7.12	4.06	3.50	6.44	2.50

\*VA capacity at 24 volt secondary tap only. To determine VA capacity at other secondary taps, multiply voltage of tap being used by maximum secondary current. Example: Using 8 volt tap on 36-10-A, VA capacity would be 8 (volts) x 4.16 (amps) = 33.6 VA.

**Shaded catalog numbers** on this page indicate transformers **not** carried in factory stock. Consult factory or your Dongan Representative for price and delivery.

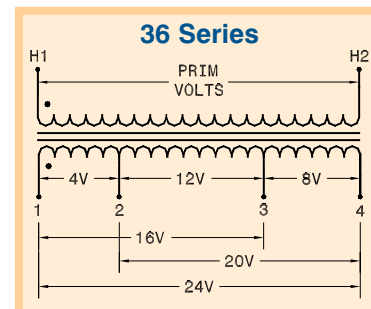
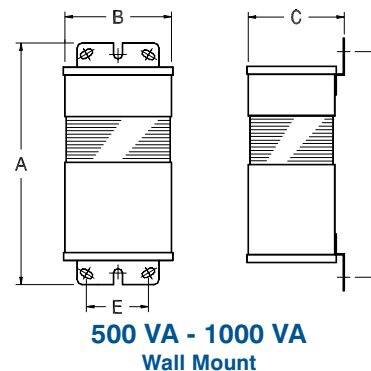
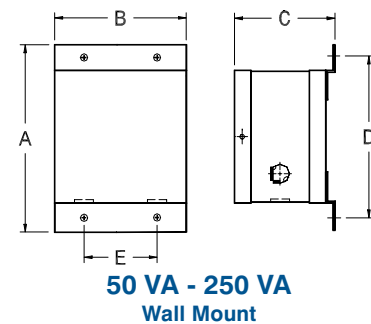

Dimensions & weights may change.  
Consult factory for certified drawings.

## Series HL - Hazardous Location

DONGAN ELECTRIC MANUFACTURING CO. • 2987 FRANKLIN • DETROIT, MI 48207  
 800.428.2626 • 313.567.8500 • FAX 313.567.8828 • www.dongan.com

Series HL - Hazardous Location Transformers are designed for applications where the possibility of a fire or explosion may result from sparks in environments containing high concentrations of dust, gases or other volatile substances.

Series HL transformer's wiring compartments are completely filled with electrical grade silica and resin, leaving no access to the core and coil or other internal components. This feature also minimizes air spaces where combustible particulates and gases may accumulate. The transformer's lead length is sufficient to allow connection to customer provided explosion-proof boxes.

*Note: all unused leads must be insulated in accordance with all applicable codes and standards.*

## Features

- **UL Recognized Component E100887**
- NEMA 12 indoor/outdoor enclosure.
- Capacity range from .500 kVA to 25 kVA.
- Primary and secondary leads are approximately 18 inches long.
- Available primary voltages include 120, 208, 240, 277, 480, 600, 60 Hertz.
- Consult factory for desired voltage combinations and VA sizes not listed.
- Stainless steel enclosures are also available.
- Electrostatic shield provided on all units.

General Information											
Pri. Volts	240 x 480	120 x 240	208	277	600	Dimensions (inches)					Weight (lbs)
Sec. Volts	120 / 240	120 / 240	120 / 240	120 / 240	120 / 240	Height A	Width B	Depth C	Mounting		
	60 Hz	60 Hz	60 Hz	60 Hz	60 Hz				D	E	
kVA Cap.	Catalog Number	Catalog Number	Catalog Number	Catalog Number	Catalog Number	Height A	Width B	Depth C	D	E	Weight (lbs)
.500	HL12-1025SH	HL12-6025SH	HL12-3025SH	HL12-4025SH	HL12-5025SH	10.50	10.00	6.62	6.12	4.00	40
.750	HL12-1030SH	HL12-6030SH	HL12-3030SH	HL12-4030SH	HL12-5030SH	10.50	10.00	6.62	6.12	4.00	42
1.0	HL12-1035SH	HL12-6035SH	HL12-3035SH	HL12-4035SH	HL12-5035SH	10.50	10.00	6.62	6.12	4.00	45
1.5	HL12-1040SH	HL12-6040SH	HL12-3040SH	HL12-4040SH	HL12-5040SH	10.50	10.00	6.62	6.12	4.00	50
2.0	HL12-1045SH	HL12-6045SH	HL12-3045SH	HL12-4045SH	HL12-5045SH	12.00	10.81	7.19	6.69	6.00	75
3.0	HL12-1050SH	HL12-6050SH	HL12-3050SH	HL12-4050SH	HL12-5050SH	12.00	10.81	7.19	6.69	6.00	80
5.0	HL12-1055SH	HL12-6055SH	HL12-3055SH	HL12-4055SH	HL12-5055SH	14.00	14.00	9.25	8.75	8.00	140
7.5	HL12-1060SH	HL12-6060SH	HL12-3060SH	HL12-4060SH	HL12-5060SH	14.00	14.38	10.25	9.75	8.00	205
10	HL12-1065SH	HL12-6065SH	HL12-3065SH	HL12-4065SH	HL12-5065SH	14.00	14.38	10.25	9.75	8.00	230
15	HL12-1070SH	HL12-6070SH	HL12-3070SH	HL12-4070SH	HL12-5070SH	15.00	18.00	12.50	12.00	8.00	260
25	HL12-1075SH	HL12-6075SH	HL12-3075SH	HL12-4075SH	HL12-5075SH	15.00	18.00	12.50	12.00	8.00	320

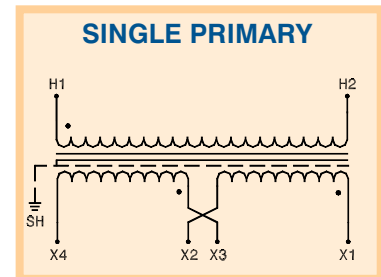
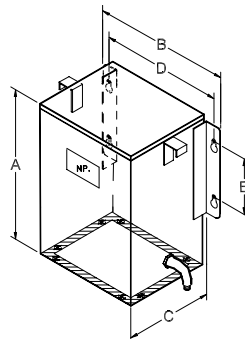
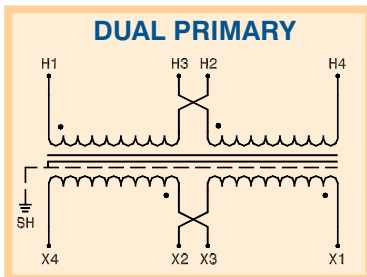

### Series HL

Wall Mount - Encapsulated - NEMA 12 - IP54

Dimensions & weights may change. Consult factory for certified drawings.



# Series 21HG - Hospital Isolation Transformers

Series 21HG - Medical Isolation Transformers are designed for installations requiring the use of an isolated, single phase power supply in nonhazardous areas of health care facilities. They feature low leakage current values of 20 to 50 microamperes demanded in hospital line isolation applications.

The low profile series feature “pancake” designs to fit shallow wire ways and enclosures for operating rooms and other demanding hospital environments. All Series 21HG feature electrostatic shields and convenient mechanical compression terminals. Other terminations including wire leads are available by consulting the factory or your Dongan Representative.

Series 21HG are UL Recognized under Standards UL1047 and UL 506, File E155483.

## Features

- **UL Recognized, File E155483.**
- **Complies with UL Standards 506 & 1047.**
- Core and Coil designs, 60 Hertz.
- UL Recognized 200°C insulation system File E100887.
- Single Phase designs in sizes:  
3 kVA to 15 kVA - Low Profile Style.  
15 kVA to 37.5 kVA - Upright Style.
- Ground terminal and electrostatic shield provided on all units.
- All Copper windings.
- Leakage current values range from 20 to 50 microamperes depending on kVA size and secondary voltage.
- Consult factory for desired voltage combinations and kVA sizes not listed.

General Information												
Pri. Volts	120	208	240	277	277	480	Dimensions (inches)					Weight (lbs)
Sec. Volts	120	120	120	120	208	120	Height A	Width B	Depth C	Mounting		
	60 Hz	60 Hz	60 Hz	60 Hz	60 Hz	60 Hz				D	E	
kVA Cap.	Catalog Number	Catalog Number	Catalog Number	Catalog Number	Catalog Number	Catalog Number						
<b>Low Profile Series, Prefix 21HG</b>												
Choose Suffix below for proper voltage / kVA combination												
3	-0313	-0301	-0305	-0302	-0308	-0304	12.50	14.00	4.25	11.25	12.75	65
5	-0513	-0501	-0505	-0502	-0508	-0504	12.50	15.00	4.88	11.25	12.75	100
7.5	-0713	-0701	-0705	-0702	-0708	-0704	14.50	18.00	4.50	13.25	15.25	115
10	-1013	-1001	-1005	-1002	-1008	-1004	14.50	18.00	6.50	13.25	15.25	150
15	-1513	-1501	-1505	-1502	-1508	-1504	16.00	18.00	6.50	13.25	15.25	180
<b>Upright Series, Prefix 21HG</b>												
Choose Suffix below for proper voltage / kVA combination												
15	-1513FM	-1501FM	-1505FM	-1502FM	-1508FM	-1504FM	21.00	15.00	7.50	10.00	5.00	110
25	-2513FM	-2501FM	-2505FM	-2502FM	-2508FM	-2504FM	21.00	15.00	8.50	10.00	6.00	170
37.5	-3713FM	-3701FM	-3705FM	-3702FM	-3708FM	-3704FM	21.00	15.00	9.88	10.00	7.38	235

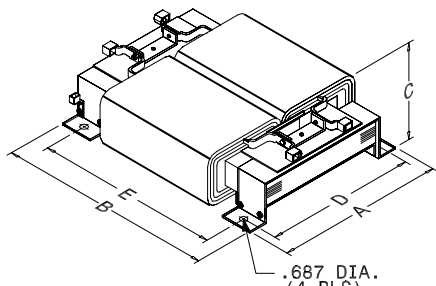

**Low Profile Series - Wall Mount**

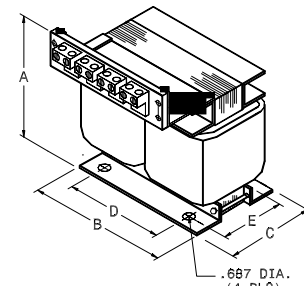
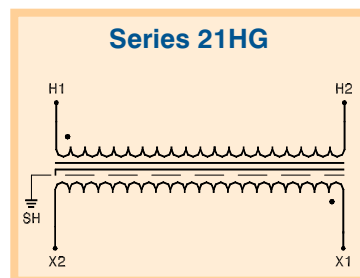

**Upright Series - Floor Mount**

Dimensions & weights may change. Consult factory for certified drawings.

## Outline Drawings

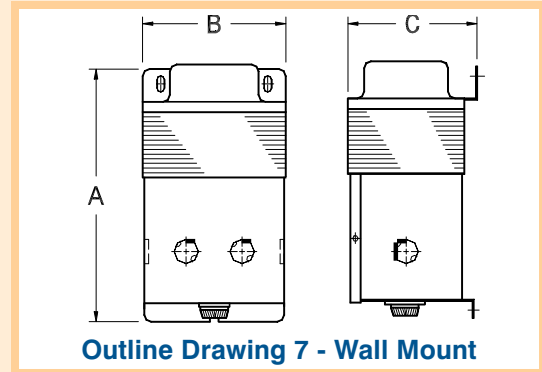
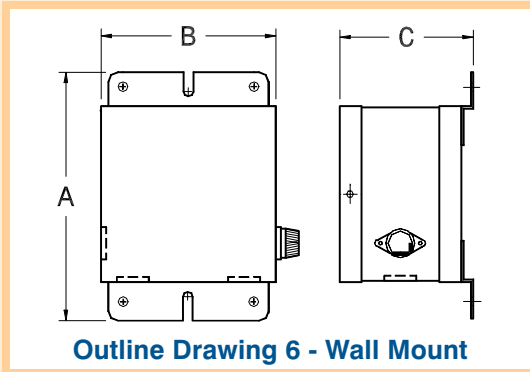
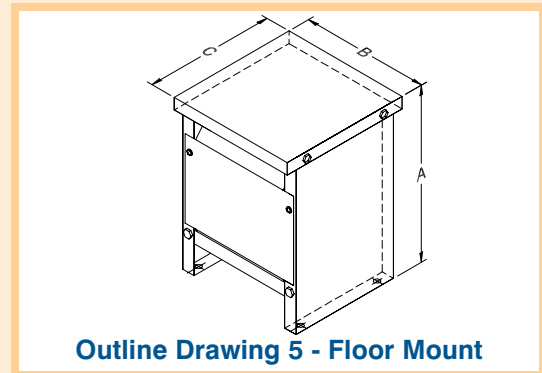
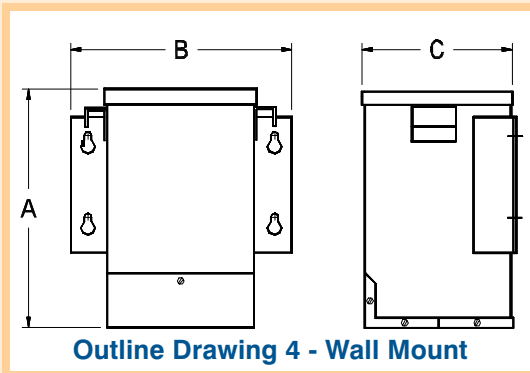
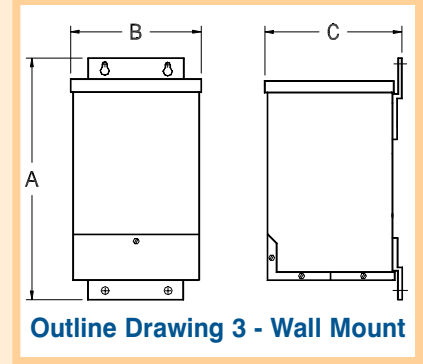
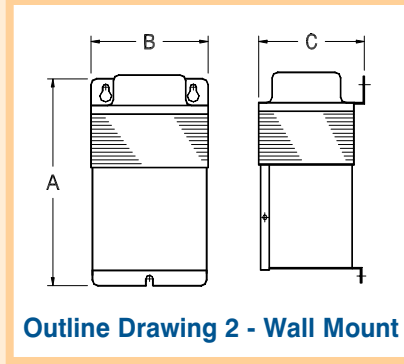
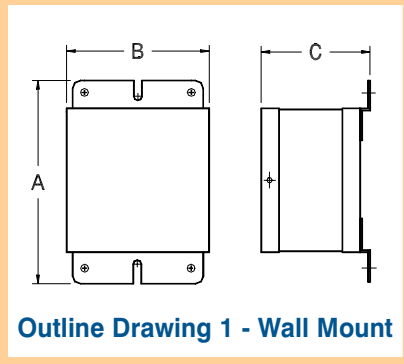

## Wall Mounting Brackets - Single Phase 7.5 kVA - 50 kVA

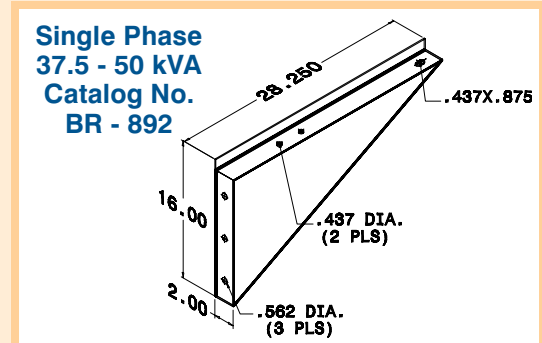
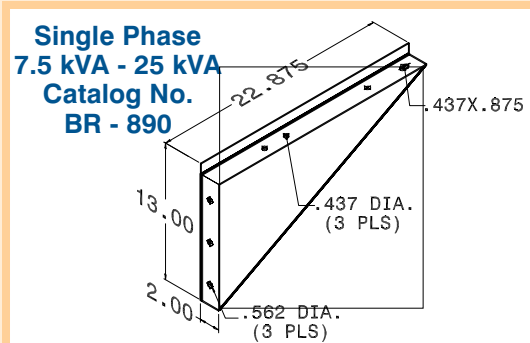



# Three Phase Transformers

## Contents

Three Phase - General Purpose .....	26
Three Phase - General Purpose Scott Connected .....	30
Three Phase - Additional Voltage Combinations Available .....	31
Three Phase - Connection Diagrams .....	32
Series 76- Large Capacity Encapsulated Transformers .....	34
Series LTF & LTH Low Temperature Rise, 80° and 115°C .....	35
Series ES-31 CE Marked .....	36
Motor Drive Isolation Transformers .....	38
K-Factor Transformers for Harmonic Loads .....	40
Three Phase - Specialty Applications .....	42
Series ODY Autotransformers .....	44
Series 3PTT Auto Test Transformers .....	44
Zig-Zag Connections .....	45
Three Phase Outline Drawings .....	46

DONGAN ELECTRIC MANUFACTURING Co. • 2987 FRANKLIN • DETROIT, MI 48207  
800.428.2626 • 313.567.8500 • Fax 313.567.8828 • www.dongan.com

### THREE PHASE: 3 kVA - 9 kVA Epoxy Encapsulated

Series 76 ISO-Shield

#### Features

- **UL Listed, File E3210.**
- **CSA Certified, File LR 560.**
- **Electrostatic shield** between primary and secondary windings provides cleaner output voltage and helps to reduce spikes and transients.
- **Epoxy-silica encapsulated** core and coil provides a transformer particularly well suited for harsh commercial and industrial applications.
- **Copper windings** and copper lead wire terminations used throughout.
- **UL Class 180°C insulation system** with a 115°C temperature rise at a maximum ambient of 40°C.
- **NEMA-3R**, wall mount enclosure suitable for indoor or outdoor use. **No extra rainshields required for outdoor use.**



3 - 9 kVA

- **Multiple knockouts** provide convenient conduit entry and exit locations through the front and bottom access wiring compartment covers.
- **Ground studs** provided for bonding compatibility with both metallic and nonmetallic conduit.
- **Nonstandard designs** are available by consulting the factory or your Dongan representative.

### THREE PHASE: 15 kVA - 150 kVA Ventilated

Series 63 ISO-Shield

#### Features

- **UL Listed, File E78234.**
- **CSA Certified, File LR 560.**
- **Electrostatic shield** between primary and secondary windings provides cleaner output voltage and helps to reduce spikes and transients.
- **Aluminum windings** connect to bus bar style terminations equipped with NEMA standard holes for compression style or ring terminals.
- **UL Class 220°C insulation system** with 150°C temperature rise at full load and a maximum ambient of 40°C.
- **NEMA-3R**, ventilated, cabinet style, floor mount enclosure suitable for indoor or outdoor use. **No extra rainshields required for outdoor use.**
- **Vibration dampening pads** provide quiet operation.



15 - 150 kVA

- **Wall Mounting brackets** are available in sizes up to 75 kVA.
- **Ground studs** provided for bonding compatibility with both metallic and nonmetallic conduit.
- **Core and coil and nonstandard designs** are available by consulting the factory or your Dongan representative.

## Three Phase - General Purpose

### THREE PHASE: 3 kVA - 9 kVA Ventilated

Series 63 Scott Connected

#### Features

- **UL Listed, File E3210.**
- **CSA Certified, File LR 560.**
- **Copper windings** and copper lead wire terminations used throughout.
- **UL Class 180°C insulation system** with a 115°C temperature rise at a maximum ambient of 40°C.
- **NEMA-3R**, wall mount enclosure suitable for vertical mount in indoor or outdoor applications. **No extra rainshields required for outdoor use.**
- **Multiple knockouts** provide convenient conduit entry and exit locations through the side and back of the wiring compartment.
- **Ground studs** provided for bonding compatibility with both metallic and nonmetallic conduit.



3 - 9 kVA

- **Slim profile** provides convenient mounting for space limited areas.
- **Neutral (X0)** provided on three phase, 4 wire transformers.

### THREE PHASE: 15 kVA - 75 kVA

63 Series Optional Wall Mounting Brackets

Three Phase 15 kVA - 45 kVA

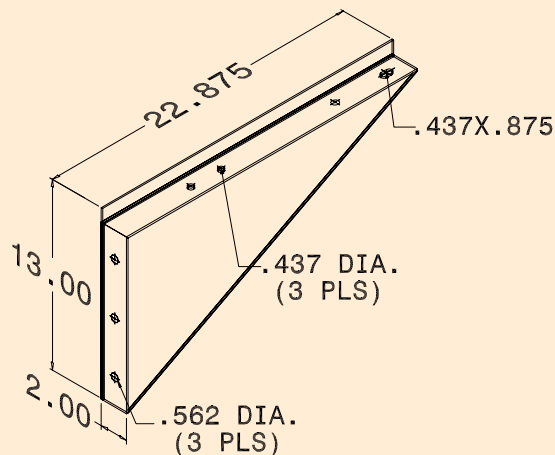

Catalog No. BR - 890

Three Phase 75 kVA

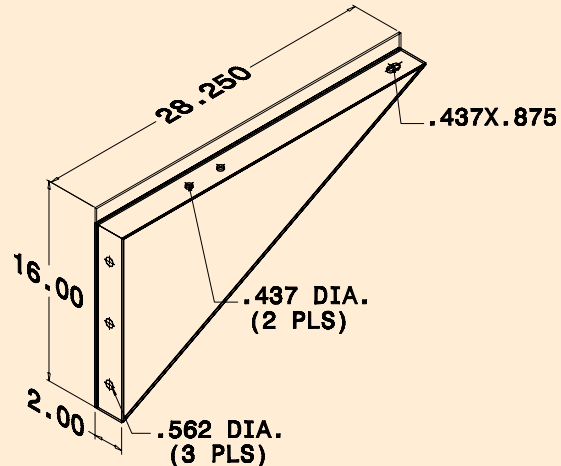

Catalog No. BR - 892



## Three Phase - General Purpose

DONGAN ELECTRIC MANUFACTURING CO. • 2987 FRANKLIN • DETROIT, MI 48207  
 800.428.2626 • 313.567.8500 • FAX 313.567.8828 • www.dongan.com

### Primary Volts 480 Delta, Secondary Volts 240 Delta, 60 Hz

May be used on a 480Y / 277 Volt Supply

General Information			Winding Specifications				Dimensions			
kVA* Cap.	Catalog Number	Wgt. Lbs	Taps	Maximum Amps		Conn Dia. Pg. 32	Height A	Width B	Depth C	Outline Dwg.
				Pri.	Sec.					
3.0	76-0203SH	140	0	3.6	7.2	2	14.00	16.00	7.75	1
6.0	76-0206SH	212	0	7.2	14.4	2	18.00	20.00	9.50	1
9.0	76-0209SH	265	0	10.8	21.6	2	18.00	20.00	9.50	1
15.0	63-6215SH	230	6	18	36	3	23.50	18.88	18.50	2
25.0	63-6225SH	255	6	30	60	3	29.00	24.25	20.88	2
30.0	63-6230SH	326	6	36	72	3	29.00	24.25	20.88	2
45.0	63-6245SH	460	6	54	108	3	29.00	24.25	20.88	2
75.0	63-6275SH	722	6	90	180	3	32.00	27.25	26.25	2
112.5	63-62112SH	1001	6	135	270	3	41.00	34.25	26.75	2
150.0	63-62150SH	1255	6	180	361	3	41.00	34.25	26.75	2

\*Transformers 15 kVA through 150 kVA are equipped with a 120 volt lighting tap. Lighting tap capacity is limited to 5% of nameplate rating distributed equally on either side of XO.

Connection Diagrams may be found on Pg. 32

#### Tap Configurations:

- 0 = No Taps
- 2 = 1 - 5% FCAN, 1 - 5% FCBN
- 4 = 2 - 2½% FCAN, 2 - 2½% FCBN
- 6 = 2 - 2½% FCAN, 4 - 2½% FCBN

Dimensions & weights may change. Consult factory for certified drawings.

### Primary Volts 480 Delta, Secondary Volts 208Y / 120, 60 Hz

May be used on a 480Y / 277 Volt Supply

General Information			Winding Specifications				Dimensions			
kVA Cap.	Catalog Number	Wgt. Lbs	Taps	Maximum Amps		Conn Dia. Pg. 32	Height A	Width B	Depth C	Outline Dwg.
				Pri.	Sec.					
3.0	76-0303SH	140	0	3.6	8.3	5	14.00	16.00	7.75	1
6.0	76-0306SH	212	0	7.2	16.6	5	18.00	20.00	9.50	1
9.0	76-0309SH	265	0	10.8	25	5	18.00	20.00	9.50	1
15.0	63-6315SH	230	6	18	41	6	23.50	18.88	18.50	2
25.0	63-6325SH	255	6	30	69	6	29.00	24.25	20.88	2
30.0	63-6330SH	326	6	36	83	6	29.00	24.25	20.88	2
45.0	63-6345SH	460	6	54	125	6	29.00	24.25	20.88	2
75.0	63-6375SH	722	6	90	208	6	32.00	27.25	26.25	2
112.5	63-63112SH	1001	6	135	312	6	41.00	34.25	26.75	2
150.0	63-63150SH	1255	6	180	416	6	41.00	34.25	26.75	2

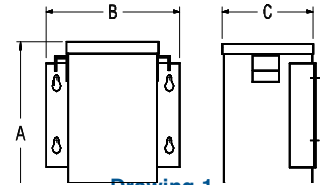

Drawing 1  
3 - 9 kVA

Wall Mount - Encapsulated - NEMA 3R

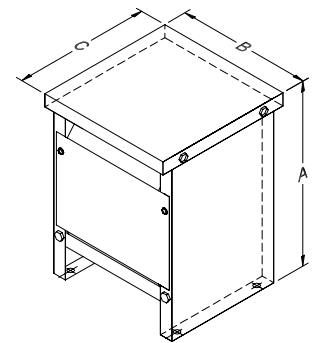

Drawing 2  
15 - 150 kVA

Floor Mount - Ventilated - NEMA 3R

## Three Phase - General Purpose

### Primary 600 Delta, Secondary 240 Delta, 60 Hz

General Information			Winding Specifications				Dimensions			
kVA* Cap.	Catalog Number	Wgt. Lbs	Taps	Maximum Amps		Conn Dia. Pg. 33	Height A	Width B	Depth C	Outline Dwg.
				Pri.	Sec.					
3.0	76-01003SH	140	0	2.8	7.2	9	14.00	16.00	7.75	1
6.0	76-01006SH	212	0	5.7	14.4	9	18.00	20.00	9.50	1
9.0	76-01009SH	265	0	8.6	21.6	9	18.00	20.00	9.50	1
15	63-61015SH	230	6	14.4	36.1	10	23.50	18.88	18.50	2
25	63-61025SH	255	6	24.0	60	10	29.00	24.25	20.88	2
30	63-61030SH	326	6	28.9	72	10	29.00	24.25	20.88	2
45	63-61045SH	460	6	43.3	108	10	29.00	24.25	20.88	2
75	63-61075SH	722	6	72	180	10	32.00	27.25	26.25	2
112.5	63-610112SH	1001	6	108	270	10	41.00	34.25	26.75	2
150	63-610150SH	1255	6	144	361	10	41.00	34.25	26.75	2

\*Transformers 15 kVA through 150 kVA are equipped with a 120 volt lighting tap. Lighting tap capacity is limited to 5% of nameplate rating distributed equally on either side of XO.

Connection Diagrams may be found on Pg. 33

#### Tap Configurations:

0 = No Taps  
 2 = 1 - 5% FCAN, 1 - 5% FCBN  
 4 = 2 - 2½% FCAN, 2 - 2½% FCBN  
 6 = 2 - 2½% FCAN, 4 - 2½% FCBN

Dimensions & weights may change. Consult factory for certified drawings.

### Primary 600 Delta, Secondary 208Y / 120, 60 Hz

General Information			Winding Specifications				Dimensions			
kVA Cap.	Catalog Number	Wgt. Lbs	Taps	Maximum Amps		Conn Dia. Pg. 33	Height A	Width B	Depth C	Outline No.
				Pri.	Sec.					
3.0	76-0003SH	140	0	2.8	8.3	11	14.00	16.00	7.75	1
6.0	76-0006SH	212	0	5.7	7.2	11	18.00	20.00	9.50	1
9.0	76-0009SH	265	0	8.6	10.8	11	18.00	20.00	9.50	1
15	63-6015SH	230	6	14.4	41.6	12	23.50	18.88	18.50	2
25	63-6025SH	255	6	24.0	69	12	29.00	24.25	20.88	2
30	63-6030SH	326	6	28.9	83	12	29.00	24.25	20.88	2
45	63-6045SH	460	6	43.3	125	12	29.00	24.25	20.88	2
75	63-6075SH	722	6	72	208	12	32.00	27.25	26.25	2
112.5	63-60112SH	1001	6	108	312	12	41.00	34.25	26.75	2
150	63-60150SH	1255	6	144	416	12	41.00	34.25	26.75	2

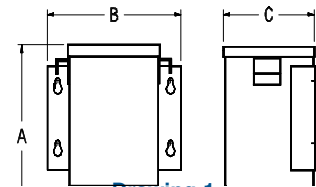

Drawing 1  
3 - 9 kVA

Wall Mount - Encapsulated - NEMA 3R

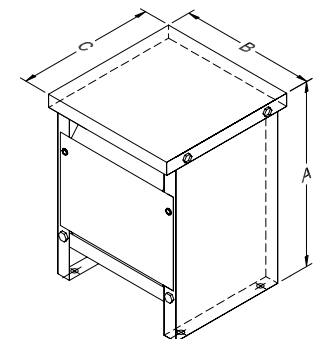

Drawing 2  
15 - 150 kVA

Floor Mount - Ventilated - NEMA 3R

### Primary 240 Delta, Secondary 208Y / 120, 60 Hz

General Information			Winding Specifications				Dimensions			
kVA Cap.	Catalog Number	Wgt. Lbs	Taps	Maximum Amps		Conn Dia. Pg. 33	Height A	Width B	Depth C	Outline Dwg.
				Pri.	Sec.					
3.0	76-0603SH	140	0	7.2	8.3	7	14.00	16.00	7.75	1
6.0	76-0606SH	212	0	14.4	16.6	7	18.00	20.00	9.50	1
9.0	76-0609SH	265	0	21.6	25	7	18.00	20.00	9.50	1
15	63-6615SH	230	6	36.1	41	8	23.50	18.88	18.5	2
25	63-6625SH	255	6	60	69	8	29.00	24.25	20.88	2
30	63-6630SH	326	6	72	83	8	29.00	24.25	20.88	2
45	63-6645SH	460	6	108	125	8	29.00	24.25	20.88	2

## VENTILATED SCOTT CONNECTED

**Primary Volts 480 Delta,  
Secondary Volts 240 Delta, 60 Hz**

May be used on a 480Y / 277 Volt Supply

General Information			Winding Specifications				Dimensions			
kVA* Cap.	Catalog Number	Wgt. Lbs	Taps	Maximum Amps		Conn Dia. Pg. 32	Height A	Width B	Depth C	Outline Dwg.
				Pri.	Sec.					
3.0	63-0203	65	0	3.6	7.2	1	15.75	6.63	5.88	3
6.0	63-0206	98	0	7.2	14.4	1	20.25	7.69	6.75	3
9.0	63-0209	164	0	10.8	21.6	1	25.63	7.69	6.75	3

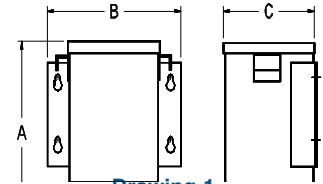

**Drawing 1**  
3 - 9 kVA  
Wall Mount - Encapsulated - NEMA 3R

**Primary Volts 480 Delta,  
Secondary Volts 208Y / 120, 60 Hz**

May be used on a 480Y / 277 Volt Supply

General Information			Winding Specifications				Dimensions			
kVA Cap.	Catalog Number	Wgt. Lbs	Taps	Maximum Amps		Conn Dia. Pg. 32	Height A	Width B	Depth C	Outline Dwg.
				Pri.	Sec.					
3.0	63-0303	65	0	3.6	8.3	4	15.75	6.63	5.88	3
6.0	63-0306	98	0	7.2	16.6	4	20.25	7.69	6.75	3
9.0	63-0309	164	0	10.8	25.0	4	25.63	7.69	6.75	3

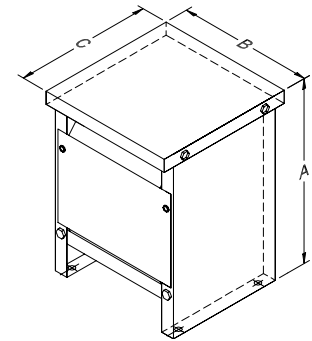

**Drawing 2**  
15 - 150 kVA  
Floor Mount - Ventilated - NEMA 3R

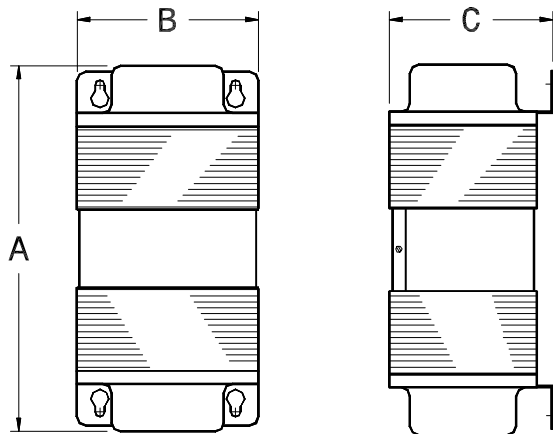

**Drawing 3**  
3 - 9 kVA, Scott Connected  
Wall Mount - Ventilated - NEMA 3R

Connection Diagrams may be found on Pg. 32

**Tap Configurations:**

- 0 = No Taps
- 2 = 1 - 5% FCAN, 1 - 5% FCBN
- 4 = 2 - 2½% FCAN, 2 - 2½% FCBN
- 6 = 2 - 2½% FCAN, 4 - 2½% FCBN

Dimensions & weights may change. Consult factory for certified drawings.

## Three Phase - General Purpose

### ADDITIONAL VOLTAGE COMBINATIONS AVAILABLE

Prefix 63 = UL Listed File E78234, CSA Certified LR 560

Prefix 76 = UL Listed File E3210, CSA Certified File LR 560

General Information								
Pri.	208 Δ	208 Δ	380 Δ	380 Δ	380 Δ	400 Δ	Wgt. (lbs) 60 Hz.	Outline Dwg.
Sec.	208Y/120	480Y/277	208Y/120	240 Δ	480 Δ	220Y/127		
Hz.	60	60	50/60*	50/60*	50/60*	50/60*		
kVA Cap.	Catalog Number	Catalog Number	Catalog Number	Catalog Number	Catalog Number	Catalog Number		
3	76-3-1161SH	76-3-704SH	76-3-407	76-3-594	76-3-834	76-3-2993	140	1
6	76-6-1161SH	76-6-704SH	76-6-407	76-6-594	76-6-834	76-6-2993	212	1
9	76-9-1161SH	76-9-704SH	76-9-407	76-9-594	76-9-834	76-9-2993	265	1
15	63-15-1161SH	63-15-704SH	63-15-407	63-15-594	63-15-834	63-15-2993	230	2
30	63-30-1161SH	63-30-704SH	63-30-407	63-30-594	63-30-834	63-30-2993	326	2
45	63-45-1161SH	63-45-704SH	63-45-407	63-45-594	63-45-834	63-45-2993	460	2
75	63-75-1161SH	63-75-704SH	63-75-407	63-75-594	63-75-834	63-75-2993	722	2
112.5	63-112-1161SH	63-112-704SH	63-112-407	63-112-594	63-112-834	63-112-2993	1001	2
150	63-150-1161SH	63-150-704SH	63-150-407	63-150-594	63-150-834	63-150-2993	1255	2

General Information								
Pri.	415 Δ	415 Δ	480 Δ	600 Δ	600 Δ	400 Δ	Wgt. (lbs) 60 Hz.	Outline Dwg.
Sec.	208Y/120	240 Δ	480Y/277	380Y/220	480Y/277	600Y/347		
Hz.	50/60*	50/60*	60	60	60	50/60*		
kVA Cap.	Catalog Number	Catalog Number	Catalog Number	Catalog Number	Catalog Number	Catalog Number		
3	76-3-3117	76-3-730	76-3-264SH	76-3-1937	76-3-2995SH	76-3-2996	140	1
6	76-6-3117	76-6-730	76-6-264SH	76-6-1937	76-6-2995SH	76-6-2996	212	1
9	76-9-3117	76-9-730	76-9-264SH	76-9-1937	76-9-2995SH	76-9-2996	265	1
15	63-15-3117	63-15-730	63-15-264SH	63-15-1937	63-15-2995SH	63-15-2996	230	2
30	63-30-3117	63-30-730	63-30-264SH	63-30-1937	63-30-2995SH	63-30-2996	326	2
45	63-45-3117	63-45-730	63-45-264SH	63-45-1937	63-45-2995SH	63-45-2996	460	2
75	63-75-3117	63-75-730	63-75-264SH	63-75-1937	63-75-2995SH	63-75-2996	722	2
112.5	63-112-3117	63-112-730	63-112-264SH	63-112-1937	63-112-2995SH	63-112-2996	1001	2
150	63-150-3117	63-150-730	63-150-264SH	63-150-1937	63-150-2995SH	63-150-2996	1255	2

\*50/60 Hz. units are approximately 20% heavier than 60 Hz. unit weights shown.

Connection Diagrams furnished upon request.  
Please consult the factory or your Dongan  
Representative for price, delivery and dimensions.

Dongan specializes in rapid delivery of nonstandard kVA, voltage and tap configurations. Send us your request today for a competitive quote on transformers not specifically listed in this catalog. Most special designs are UL listed and CSA certified at no additional cost.

# Three Phase Connection Diagrams

DONGAN ELECTRIC MANUFACTURING CO. • 2987 FRANKLIN • DETROIT, MI 48207  
 800.428.2626 • 313.567.8500 • FAX 313.567.8828 • www.dongan.com

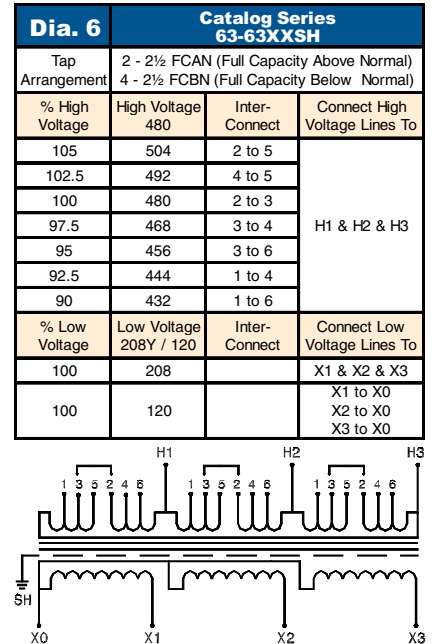
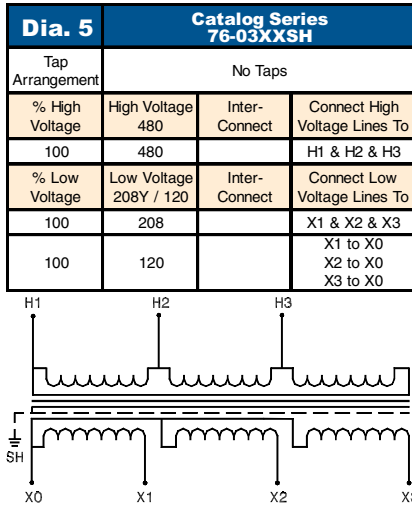
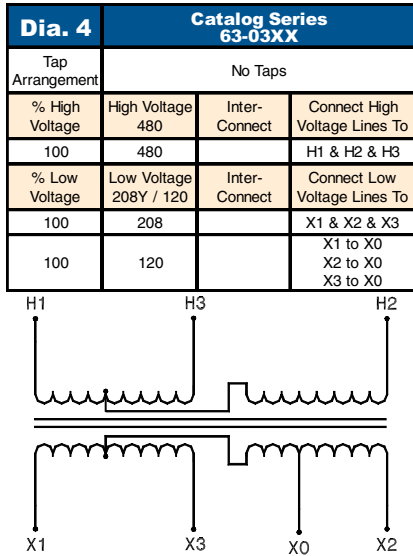
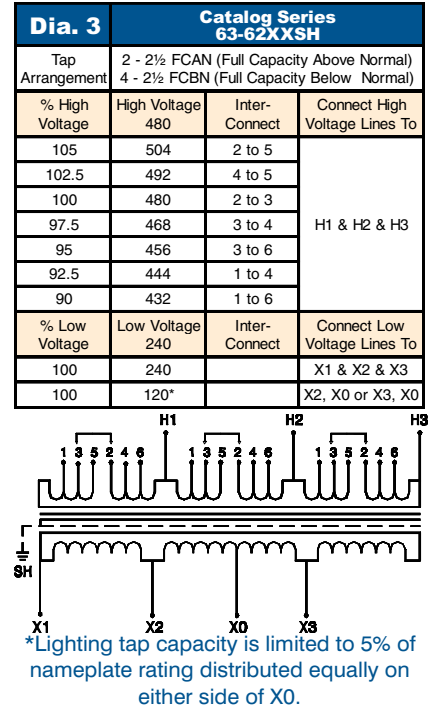
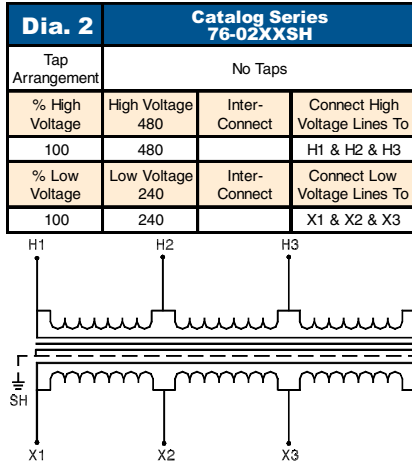
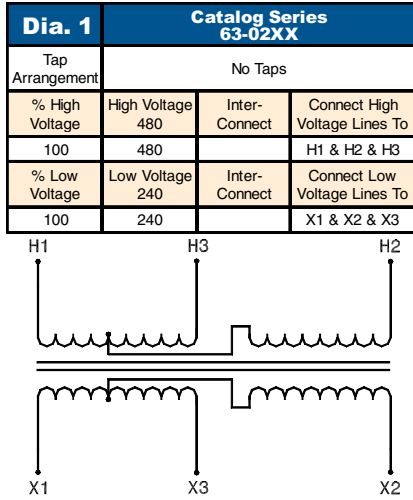



# Three Phase Connection Diagrams

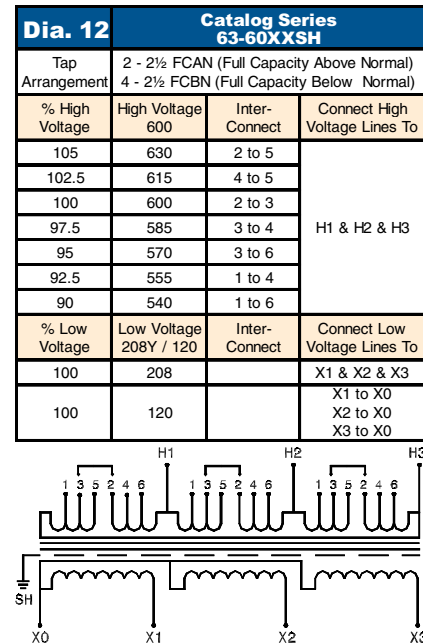
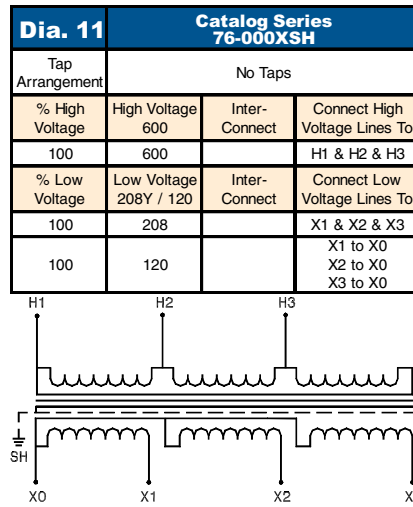
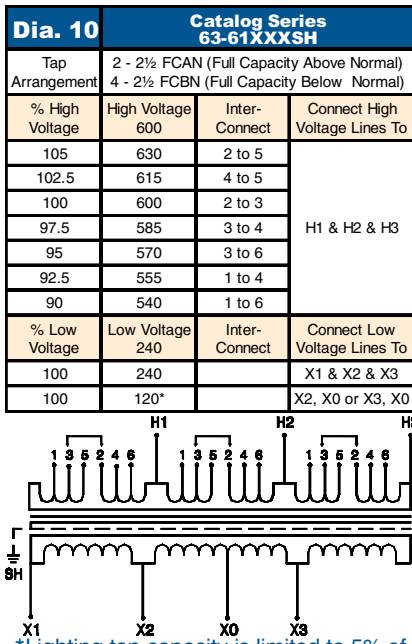
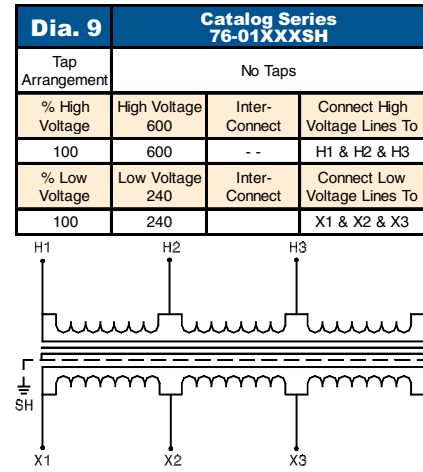
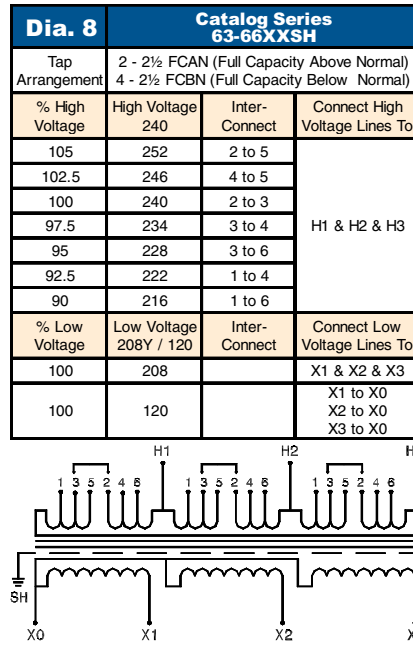
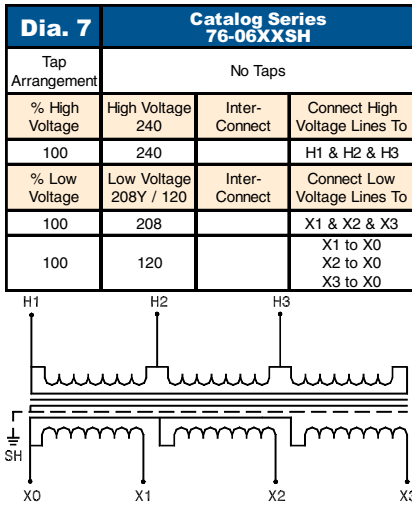

\*Lighting tap capacity is limited to 5% of nameplate rating distributed equally on either side of X0.

DONGAN ELECTRIC MANUFACTURING CO. • 2987 FRANKLIN • DETROIT, MI 48207  
 800.428.2626 • 313.567.8500 • FAX 313.567.8828 • www.dongan.com

## SERIES 76 - LARGE CAPACITY ENCAPSULATED TRANSFORMERS

Series 76 Three Phase Isolation Transformers offer all the advantages of encapsulated transformers - in larger kVA sizes. These transformers are particularly well suited to harsher environments where airborne contaminants may adversely effect ventilated, dry type transformers.

Available in 600 and 480 volt primaries, these transformers feature a 115°C temperature rise, 200°C insulation system, electrostatic shields, and copper windings. The core and coil are completely epoxy-silica encapsulated for protection against environmental contaminates.

### Features

- **UL Listed, File E3210.**
- **CSA Certified, LR 560.**
- NEMA 3R, indoor / outdoor enclosure.
- Copper wound, 115°C temperature rise.
- Epoxy-silica encapsulated core and coil construction.
- Featuring three phase 600 or 480 volt Delta primary windings with a secondary winding of 208Y/120.
- Special order options include stainless steel enclosures.

General Information				Winding Specifications					Dimensions			
kVA Cap.	Pri. 600 Δ	Pri. 480 Δ	Hz.	Taps	Maximum Amps			Wall Mount (WM) Floor Mount (FM)	Height A	Width B	Depth C	Wgt. (lbs)
	Sec. 208Y/120	Sec. 208Y/120			Pri. 600 Δ	Pri. 480 Δ	Sec. 208Y/120					
	Catalog No.	Catalog No.										
15	76-2015SH	76-2315SH	60	2	14.4	18.0	41.6	WM	18.00	20.00	9.50	220
25	76-2025SH	76-2325SH	60	2	24.0	30.0	69.3	FM	27.50	20.75	19.50	380
30	76-2030SH	76-2330SH	60	2	28.9	36.1	83.0	FM	27.50	20.75	19.50	425
45	76-2045SH	76-2345SH	60	2	43.3	54.0	125.0	FM	27.50	20.75	19.50	550
75	76-2075SH*	76-2375SH	60	2	72.0	90.0	208	FM	34.75	34.00	23.00	950

\*75 kVA is not UL Listed or CSA Certified.

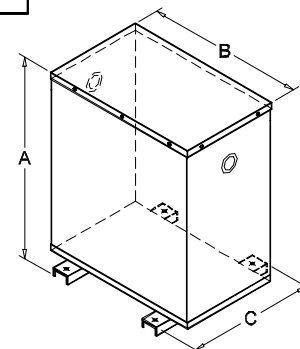
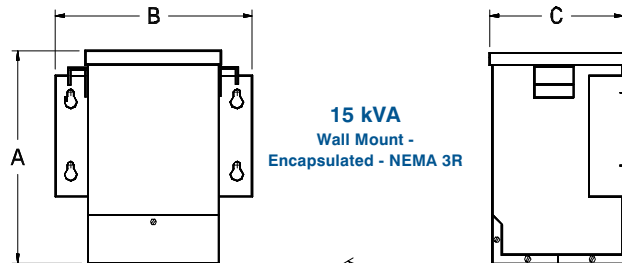
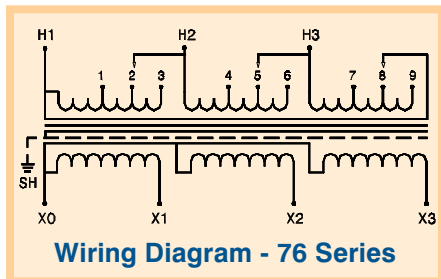

## Three Phase - General Purpose

# SERIES LTF & LTH - LOW TEMPERATURE RISE, 80°C AND 115°C

Series LTF and LTH Transformers are three phase, low temperature rise, air cooled, general purpose distribution transformers. These transformers feature either an 80°C temperature rise or a 115°C temperature rise with a 220°C insulation system and all are shielded. They are designed for applications where cool operating temperatures or thermal overload requirements are demanded.

Thermal overload capability of 15% to 30% is built in because these units are designed to operate with a maximum rise of 150°C. This means units with an 80°C rise have a 70°C thermal reserve and units with a 115°C rise have a 35°C thermal reserve. These features insure a long life where moderate thermal or capacity overloads exist.

## Features

- **UL Listed, File E78234.**
- **CSA Certified, LR 560.**
- NEMA 3R, indoor / outdoor enclosure.
- 80°C and 115°C temperature rise units.
- 220°C Insulation system.
- Featuring three phase, 480 volt Delta primary windings with a secondary winding of 208Y/120.
- Special order options include 600 and 240 volt primaries.
- 60 Hertz.

Connection Diagrams may  
at bottom of page.

### Tap Configurations:

- 0 = No Taps
- 2 = 1 - 5% FCAN, 1 - 5% FCBN
- 4 = 2 - 2½% FCAN, 2 - 2½% FCBN
- 6 = 2 - 2½% FCAN, 4 - 2½% FCBN

Dimensions & weights  
may change. Consult factory  
for certified drawings.

General Information														
kVA Cap.	Pri. 480 Δ	Pri. 480 Δ	Height A	Width B	Depth C	Wgt. (lbs)	Taps	Pri. 480 Δ	Pri. 480 Δ	Height A	Width B	Depth C	Wgt. (lbs)	Taps
	Sec. 240 Δ	Sec. 208Y/120						Sec. 240 Δ	Sec. 208Y/120					
	Catalog No.	Catalog No.						Catalog No.	Catalog No.					
9	63-LTF209SH	63-LTF309SH	29.00	24.25	20.88	280	6	63-LTH209SH	63-LTH309SH	23.50	18.88	18.50	245	6
15	63-LTF215SH	63-LTF315SH	29.00	24.25	20.88	300	6	63-LTH215SH	63-LTH315SH	29.00	24.25	20.88	280	6
25	63-LTF225SH	63-LTF325SH	29.00	24.25	20.88	450	6	63-LTH225SH	63-LTH325SH	29.00	24.25	20.88	300	6
30	63-LTF230SH	63-LTF330SH	32.00	27.25	26.25	580	6	63-LTH230SH	63-LTH330SH	29.00	24.25	20.88	450	6
45	63-LTF245SH	63-LTF345SH	41.00	34.25	26.75	1000	6	63-LTH245SH	63-LTH345SH	32.00	27.25	26.25	580	6
75	63-LTF275SH	63-LTF375SH	41.00	34.25	26.75	1200	6	63-LTH275SH	63-LTH375SH	41.00	34.25	26.75	1000	6
112.5								63-LTH2112S- H	63-LTH3112S- H	41.00	34.25	26.75	1200	6
80° Rise								115° C Rise						

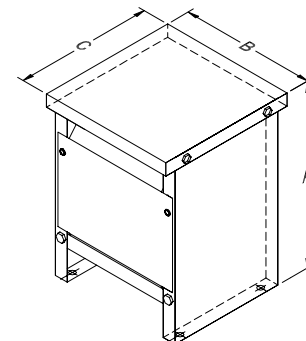
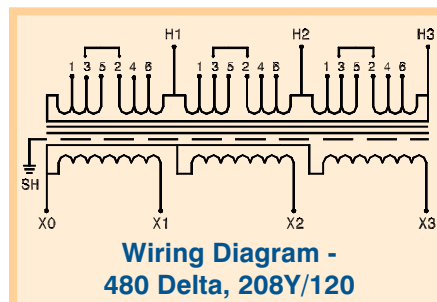
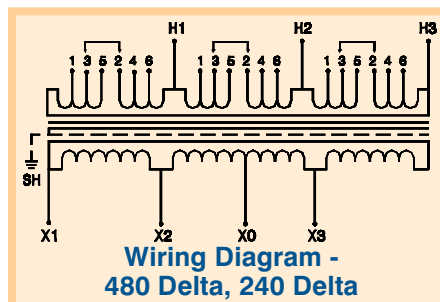

Series LTF & LTH  
Floor Mount - Ventilated - NEMA 3R

\*Lighting tap capacity is limited to 5% of nameplate rating distributed equally on either side of X0.

### SERIES ES-31 CE MARKED

Series ES Three Phase Encapsulated Transformers are designed to comply with Domestic, North American, and European Union electrical and testing standards. Series ES are UL and Canadian UL Listed by Underwriters Labs. In addition, Series ES are CE Marked, and licensed by the German testing agency TÜV Rheinland under License Number R 9679035.01.

Series ES transformers are the answer to your export needs. With the voltage combinations listed below, and built in approvals, the ES Series provide no-nonsense solutions for equipment destined for the European Community of nations.

Under EC guidelines, connecting transformers to line and load require finger safe connections. While other manufacturers provide leads, Dongan provides finger safe terminals on all ES-31 transformers. This feature eliminates the necessity of a difficult, labor intensive installation of terminals in the wiring compartment by the end user.

The voltage combinations offered represent some of the most universally used. However, any combination of primary and secondary incorporating voltages of 600 volts and below is available on a short lead time, special order basis. In addition, capacities up to 40 kVA and special temperature rise configurations can be furnished.

Please consult your distributor, Dongan Representative, or the factory for special ES Series transformer requirements.



Series ES - 31

### Features

- CE Marked
- TÜV Rheinland Licensed, R 9679035.01 Agency Compliance
- UL Listed, File E3210. 
- CSA Listed thru UL, File E3210
- NEMA 12, IP54 enclosure.
- Epoxy Encapsulated.
- All copper windings.
- IEC type finger safe terminals.
- 200°C Insulation System.
- 50/60 Hertz.
- Class 1, general use, isolating transformer.
- All Series ES are provided with an electrostatic shield (earth metal screen).
- All Series ES are provided with a color coded protective earth (PE) terminal.
- Consult factory for desired voltage combinations and kVA sizes not listed.

#### Three Phase Core & Coil Configurations Available

Dongan is licensed by TÜV Rheinland to manufacture CE Marked, three phase core and coil units up to 40 kVA. Please consult your Dongan Distributor or the factory for open style designs of ES three phase transformers.

Dimensions & weights may change. Consult factory for certified drawings.

# Three Phase Transformers

## SERIES ES-31 CE MARKED

General Information									
Pri. Volts	380 Delta	416 Delta	Dimensions (inches)						Weight (lbs)
Sec. Volts	240 / 120 Delta Center - Tapped	240 / 120 Delta Center - Tapped	A	B	C	Mounting			
kVA Cap.	Catalog Number	Catalog Number				D	E	F	
1	ES-31200.542	ES-31200.552	15.00	18.00	12.50	12.00	8.00	16.00	170
3	ES-31250.542	ES-31250.552	15.00	18.00	12.50	12.00	8.00	16.00	180
6	ES-31310.542	ES-31310.552	15.00	18.00	12.50	12.00	8.00	16.00	200
10	ES-31360.542	ES-31360.552	18.00	21.00	10.50	10.00	8.00	19.00	295
15	ES-31380.542	ES-31380.552	18.00	21.00	10.50	10.00	8.00	19.00	315
20	ES-31390.542	ES-31390.552	27.50	24.75	12.25	12.00	5.00	23.25	430
25	ES-31410.542	ES-31410.552	27.50	24.75	12.25	12.00	5.00	23.25	450
30	ES-31420.542	ES-31420.552	27.50	24.75	12.25	12.00	5.00	23.25	500
40	ES-31450.542	ES-31450.552	27.50	24.75	16.25	16.00	9.00	23.25	535

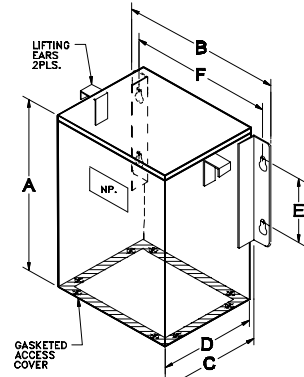

1 - 15 kVA  
Wall Mount - Encapsulated -  
NEMA 12 - IP54

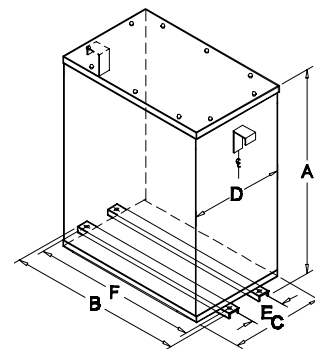

20 - 40 kVA  
Floor Mount - Encapsulated -  
NEMA 12 - IP54

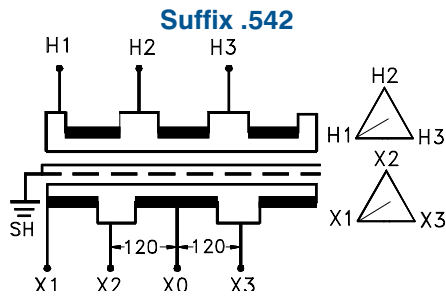

Primary Connections		Secondary Connections	
Pri. Voltage	Connect Incoming Lines To:	Sec. Voltage	Connect Load Lines To:
380 Delta, 3 Phase	H1, H2, H3	240 Delta, 3 Phase	X1, X2, X3
		120 1 Phase*	X0 & X2 X0 & X3

\* Single Phase load is limited to a maximum of 5% of nameplate kVA distributed equally on either side of X0.

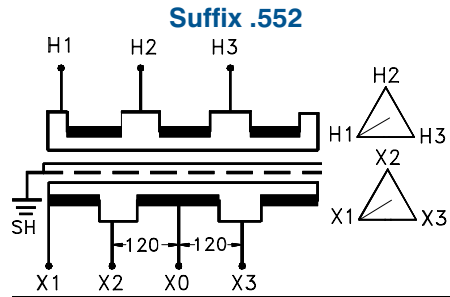

Primary Connections		Secondary Connections	
Pri. Voltage	Connect Incoming Lines To:	Sec. Voltage	Connect Load Lines To:
416 Delta, 3 Phase	H1, H2, H3	240 Delta, 3 Phase	X1, X2, X3
		120 1 Phase*	X0 & X2 X0 & X3

\* Single Phase load is limited to a maximum of 5% of nameplate kVA distributed equally on either side of X0.

### Series ES Single Phase and Industrial Control Transformers

Please see Series ES CE Marked Single Phase on page 18 - 19 and Industrial Control transformers on pages 82 - 83 of this catalog. A Declaration of Conformity is available by contacting your Dongan Representative or the factory Customer Service Department.



# Motor Drive Isolation Transformers

DONGAN ELECTRIC MANUFACTURING CO. • 2987 FRANKLIN • DETROIT, MI 48207  
800.428.2626 • 313.567.8500 • FAX 313.567.8828 • www.dongan.com

Dongan Motor Drive Isolation Transformers are specifically designed to meet the requirements of SCR controlled variable speed motor drives. They are ruggedly constructed to withstand the high mechanical forces associated with SCR drive duty cycles. The double-wound construction isolates the line from most SCR generated voltage spikes and transient feedback. These transformers also assist in reducing some types of line transient that can cause SCR misfiring.

## Features

- **UL Listed, File E78234.**
- **CSA Certified, LR560.**
- **Three Phase 3 - 145 kVA.**
- **Electrostatic shield** between windings provides cleaner output voltage and helps to reduce spikes and transients.
- **Vibration dampening pads** provide quiet operation.
- **Wall Mounting brackets** are available for sizes 11 kVA through 75 kVA (see page 29).
- **Ground studs** provided for bonding compatibility with both metallic and nonmetallic conduit.

- **Core and coil and nonstandard designs** are available by consulting the factory or your Dongan Representative.
- **3 - 7.5 kVA** are copper wound and equipped with a UL 200°C insulation system and a 115°C temperature rise. Windings connect to compression style terminals, eliminating the need to purchase additional connectors. † **NEMA-3R**, ventilated, cabinet style, wall mount enclosure suitable for indoor or outdoor use. **No extra rainshields required for outdoor use.**
- **11 - 145 kVA** are aluminum wound and equipped with a UL 220°C insulation system and a 150°C temperature rise. Windings connect to buss bar style terminations equipped with NEMA standard holes for user supplied compression style terminals. † **NEMA-3R**, ventilated, cabinet style, floor mount enclosure suitable for indoor or



11 - 145 kVA

outdoor use. **No extra rainshields required for outdoor use.**

		General Information						Taps	Weight (lbs)
Delta Pri.		230	230	460	460	575	575		
Wye Sec.		230Y/133	460Y/266	230Y/133	460Y/266	230Y/133	460Y/266		
kVA Cap.	Motor HP	Catalog Number	Catalog Number	Catalog Number	Catalog Number	Catalog Number	Catalog Number		
3	2	63-0103SH	63-0403SH	63-0503SH	63-0703SH	63-0803SH	63-0903SH	0	70
6	3	63-0106SH	63-0406SH	63-0506SH	63-0706SH	63-0806SH	63-0906SH	0	136
7.5	5	63-0107SH	63-0407SH	63-0507SH	63-0707SH	63-0807SH	63-0907SH	0	185
11	7.5	63-2111SH	63-2411SH	63-2511SH	63-2711SH	63-2811SH	63-2911SH	2	225
14	10	63-2114SH	63-2414SH	63-2514SH	63-2714SH	63-2814SH	63-2914SH	2	245
20	15	63-2120SH	63-2420SH	63-2520SH	63-2720SH	63-2820SH	63-2920SH	2	275
27	20	63-2127SH	63-2427SH	63-2527SH	63-2727SH	63-2827SH	63-2927SH	2	290
34	25	63-2134SH	63-2434SH	63-2534SH	63-2734SH	63-2834SH	63-2934SH	2	415
40	30	63-2140SH	63-2440SH	63-2540SH	63-2740SH	63-2840SH	63-2940SH	2	440
51	40	63-2151SH	63-2451SH	63-2551SH	63-2751SH	63-2851SH	63-2951SH	2	500
63	50	63-2163SH	63-2463SH	63-2563SH	63-2763SH	63-2863SH	63-2963SH	2	560
75	60	63-2175SH	63-2475SH	63-2575SH	63-2775SH	63-2875SH	63-2975SH	2	580
93	75	63-2193SH	63-2493SH	63-2593SH	63-2793SH	63-2893SH	63-2993SH	2	1000
118	100	63-21118SH	63-24118SH	63-25118SH	63-27118SH	63-28118SH	63-29118SH	2	1100
145	125	63-21145SH	63-24145SH	63-25145SH	63-27145SH	63-28145SH	63-29145SH	2	1200

Connection Diagrams may be found on Pg. 39

### Tap Configurations:

- 0 = No Taps
- 2 = 1 - 5% FCAN, 1 - 5% FCBN
- 4 = 2 - 2½% FCAN, 2 - 2½% FCBN
- 6 = 2 - 2½% FCAN, 4 - 2½% FCBN

Dimensions & weights may change. Consult factory for certified drawings.

# Motor Drive Isolation Transformers

Dimensions										
kVA	Motor HP	Physical			Mounting				Taps	Dwg. No.
		Height A	Width B	Depth C	D	E	F	Mtg Type*		
3	2	11.50	15.50	7.75	6.31	14.00	0.437	WM	0	1
6	3	14.00	18.50	9.00	8.50	17.00	0.437	WM	0	1
7.5	5	17.50	17.00	10.00	11.50	15.50	0.562	WM	0	1
11	7.5	23.50	18.87	18.50	13.00	16.87	0.437	FM	2	2
14	10	23.50	18.87	18.50	13.00	16.87	0.437	FM	2	2
20	15	29.00	24.25	20.87	15.37	22.25	0.437	FM	2	2
27	20	29.00	24.25	20.87	15.37	22.25	0.437	FM	2	2
34	25	29.00	24.25	20.87	15.37	22.25	0.437	FM	2	2
40	30	29.00	24.25	20.87	15.37	22.25	0.437	FM	2	2
51	40	32.00	27.25	26.25	20.75	25.25	0.562	FM	2	2
63	50	32.00	27.25	26.25	20.75	25.25	0.562	FM	2	2
75	60	32.00	27.25	26.25	20.75	25.25	0.562	FM	2	2
93	75	41.00	34.25	26.75	21.25	32.25	0.562	FM	2	2
118	100	41.00	34.25	26.75	21.25	32.25	0.562	FM	2	2
145	125	41.00	34.25	26.75	21.25	32.25	0.562	FM	2	2

\*WM = WALL MOUNT    FM = FLOOR MOUNT

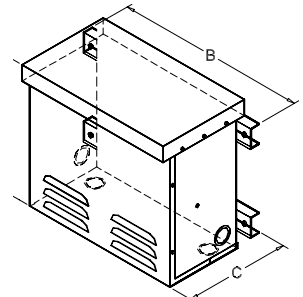

**Drawing 1**  
3 - 7.5 kVA  
Wall Mount - Ventilated - NEMA 3R

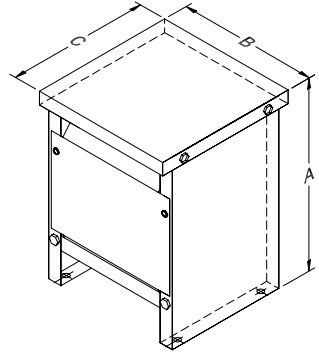

**Drawing 2**  
11 - 145 kVA  
Floor Mount - Ventilated - NEMA 3R

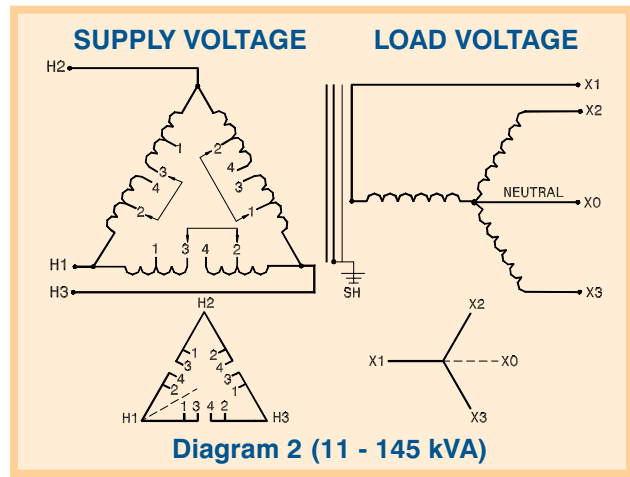
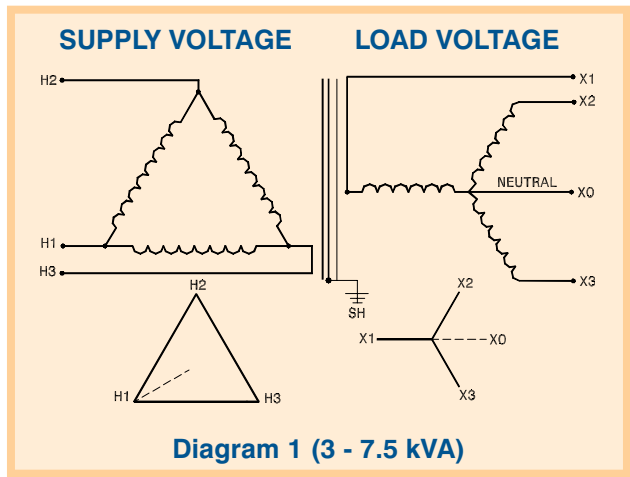

DONGAN ELECTRIC MANUFACTURING CO. • 2987 FRANKLIN • DETROIT, MI 48207  
800.428.2626 • 313.567.8500 • Fax 313.567.8828 • www.dongan.com

## K-Factor Transformers for Harmonic Loads

**DONGAN ELECTRIC MANUFACTURING Co. • 2987 FRANKLIN • DETROIT, MI 48207**  
**800.428.2626 • 313.567.8500 • FAX 313.567.8828 • www.dongan.com**

Domestic distribution systems and linear loads operate at the fundamental frequency of 60 Hz. Harmonic content in distribution systems means that there are integer multipliers of the fundamental 60 Hz frequency present. For instance, the second harmonic is 120 Hz, the third harmonic is 180 Hz, the fourth harmonic is 240 Hz, etc.

Traditionally, linear transformer loads exhibit voltage and current typically at the fundamental frequency and generally have little harmonic content. Nonlinear transformer loads, on the other hand, introduce significant harmonics into a distribution system. Harmonics are created due to the method in which nonlinear devices draw current in pulses at the voltage peak of the AC sine wave waveform.

Transformers operating in a distribution system containing significant harmonics will exhibit potentially serious effects of increased operating temperature. Additionally, it is common to find overloaded neutral conductors resulting from the additive effect of third harmonic and succeeding odd multiple harmonic current flow (triplen harmonics) as well as circulating currents in the primary, eddy current losses, and skin effect losses.

Nonlinear loads should be suspected where there is a presence of switch mode power supplies commonly found in desktop personal computers, printers, mainframes, and other electronic equipment. Other sources include electronic ballasts, variable speed AC motor drives, certain fluorescent lighting fixtures, and some types of welders. As existing distribution systems have these types of devices installed, harmonic problems multiply!

Harmonic content of a distribution system is indicated by a number called K-Factor. Larger



values of “K” indicate the presence of more harmonics in the load. Harmonic content of a load may be determined by measurement utilizing a recording analyzing meter. Linear loads have a K-Factor of 1. Switch mode power supplies have a K-Factor as high as K-20. Other nonlinear loads have a K-Factor which varies with the device.

Dongan K-Factor transformers are specifically engineered to operate at full load and full harmonic rating without exceeding the rated insulation system values - effectively neutralizing the dangerous effects of temperature and circulating currents. Windings and cores are designed to operate in the presence of triplen harmonics without overheating or forcing the core into saturation. These transformers will provide years of trouble free service to large office buildings, industrial plants, processing equipment and any load with a designated harmonic content.

### K - 4, Primary 480 Volts Delta, Secondary 208Y / 120, 60 Hz

General Information			Winding Specifications			Dimensions		
kVA Cap.	Catalog Number	Wgt. Lbs	Taps	Maximum Amps		Height A	Width B	Depth C
				Pri. 480	Sec. 208Y/120			
15.0	TK04-6315SH	280	6	18.0	41.6	23.50	18.88	18.50
30.0	TK04-6330SH	350	6	36.1	83.0	29.00	24.25	20.88
45.0	TK04-6345SH	550	6	54.0	125.0	29.00	24.25	20.88
75.0	TK04-6375SH	860	6	90.0	208.0	32.00	27.25	26.25
112.5	TK04-63112SH	1100	6	135.0	312.0	41.00	34.25	26.75
150.0	TK04-63150SH	1320	6	180.0	416.0	41.00	34.25	26.75

Connection Diagrams may be found on Pg. 41

#### Tap Configurations:

- 0 = No Taps
- 2 = 1 - 5% FCAN, 1 - 5% FCBN
- 4 = 2 - 2½% FCAN, 2 - 2½% FCBN
- 6 = 2 - 2½% FCAN, 4 - 2½% FCBN

Dimensions & weights may change. Consult factory for certified drawings.

# K-Factor Transformers for Harmonic Loads

## Features

- **UL Recognized Insulation System File E100887.**
- **Three Phase: 15 - 150 kVA**
- **Electrostatic shield** between windings provides cleaner output voltage and helps to reduce spikes and transients.
- **Aluminum windings** connect to bus bar style terminations equipped with NEMA standard holes for compression style terminals.
- **UL Class 220°C insulation system** with 150°C

- temperature rise at full load and rated ambient.
- **NEMA-3R**, ventilated, cabinet style, floor mount enclosure suitable for indoor or outdoor use. **No extra rainshields required for outdoor use.**
- **Vibration dampening pads** provide quiet operation.
- **Wall Mounting brackets** are available in sizes up to 75 kVA (See pg. 29).
- **Ground studs** provided for bonding compatibility with both metallic and nonmetallic conduit.
- **Nonstandard designs** are available by consulting the factory or your Dongan representative.

## K - 13, Primary 480 Volts Delta, Secondary 208Y / 120, 60 Hz

General Information			Winding Specifications			Dimensions		
kVA Cap.	Catalog Number	Wgt. Lbs	Taps	Maximum Amps		Height A	Width B	Depth C
				Pri. 480	Sec. 208Y/120			
15.0	TK13-6315SH	300	6	18.0	41.6	29.00	24.25	20.88
30.0	TK13-6330SH	450	6	36.1	83.0	29.00	24.25	20.88
45.0	TK13-6345SH	600	6	54.0	125.0	32.00	27.25	26.25
75.0	TK13-6375SH	950	6	90.0	208.0	41.00	34.25	26.75
112.5	TK13-63112SH	1200	6	135.0	312.0	41.00	34.25	26.75
150.0	TK13-63150SH	1400	6	180.0	416.0	41.00	34.25	26.75

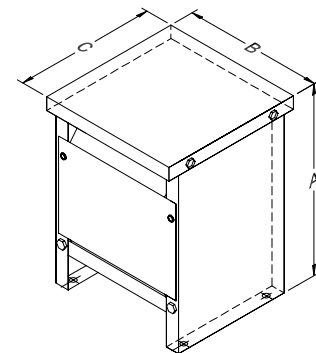

15 - 150 kVA  
Floor Mount - Ventilated - NEMA 3R

## K - 20, Primary 480 Volts Delta, Secondary 208Y / 120, 60 Hz

General Information			Winding Specifications			Dimensions		
kVA Cap.	Catalog Number	Wgt. Lbs	Taps	Maximum Amps		Height A	Width B	Depth C
				Pri. 480	Sec. 208Y/120			
15.0	TK20-6315SH	350	6	18.0	41.6	29.00	24.25	20.88
30.0	TK20-6330SH	550	6	36.1	83.0	29.00	24.25	20.88
45.0	TK20-6345SH	650	6	54.0	125.0	32.00	27.25	26.25
75.0	TK20-6375SH	1000	6	90.0	208.0	41.00	34.25	26.75
112.5	TK20-63112SH	1300	6	135.0	312.0	41.00	34.25	26.75
150.0	TK20-63150SH	1700	6	180.0	416.0	44.00	48.00	30.00

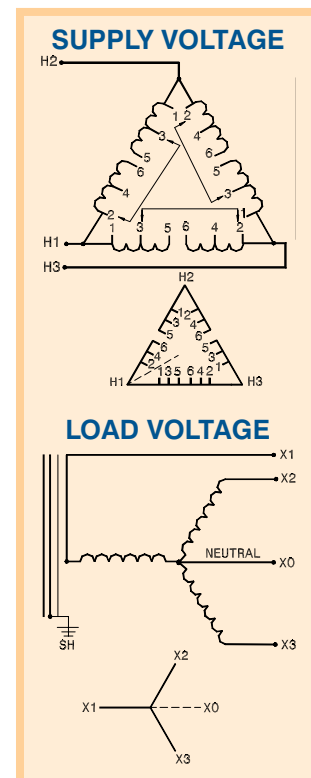

## THREE PHASE ISOLATED BANKS OF 2 OR 3 SINGLE PHASE TRANSFORMERS

Single phase, stock, general purpose transformers may be banked to achieve a variety of three phase voltage combinations. These combinations are achieved by connecting two or three identical 240/480 volt, or 600 volt primary, single phase transformers into three phase banks. When connected per the diagrams, these banks provide isolation between primary and secondary just as a three phase, general purpose transformer would.

Typically, banks of three single phase transformers are connected in a Delta Primary and Delta Secondary, or a Delta Primary and Wye Secondary configuration. The capacity of the three unit, three phase bank is equal to the sum of the individual single phase kVA ratings. For example, three single phase 10 kVA transformers connected in this

manner will have a capacity of 3 x 10 kVA - or 30 kVA, three phase.

Conversely, two transformer banks are connected almost solely in an Open Delta configuration. The capacity of the 2 unit, three phase bank is equal to the sum of the individual single phase kVA ratings multiplied by 86.6% (.866). For example, two single phase 10 kVA transformers connected in this manner will have a capacity of 2 x 10 kVA x .866 - or 17.3 kVA, three phase.

The configurations shown represent some of the more popular combinations. Please consult the factory to obtain information on any configuration not shown in the charts below.

**O INDICATES OVERCURRENT PROTECTION**

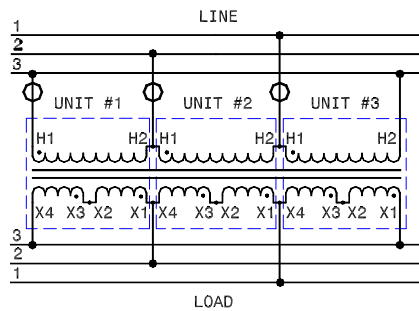

600 Δ, 240 Δ, 3 Phase - 3 Unit Bank

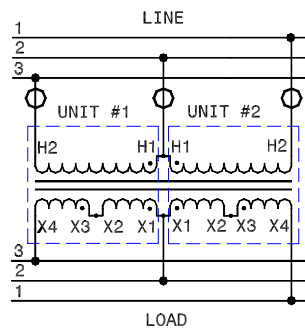

600 Δ, 240 Δ, 3 Phase - 2 Unit Bank

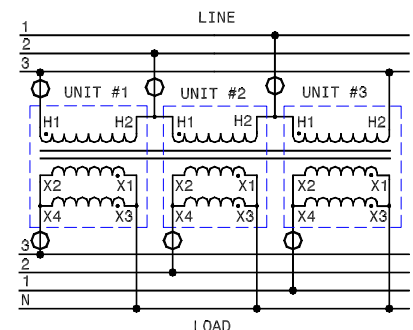

600 Δ, 208Y/120, 3 Phase - 3 Unit Bank

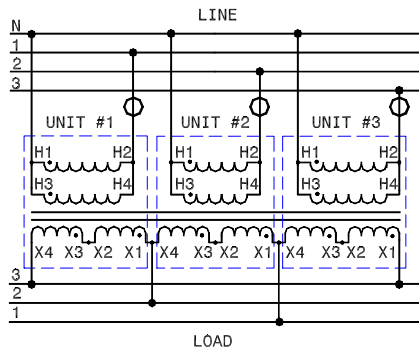

415Y/240, 240 Δ, 3 Phase - 3 Unit Bank

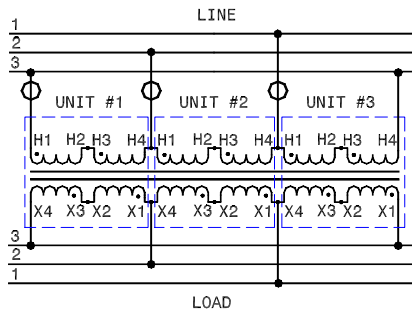

480 Δ, 240 Δ, 3 Phase - 3 Unit Bank

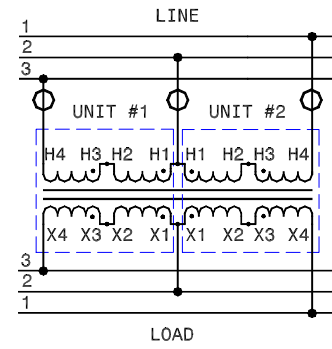

480 Δ, 240 Δ, 3 Phase - 2 Unit Bank

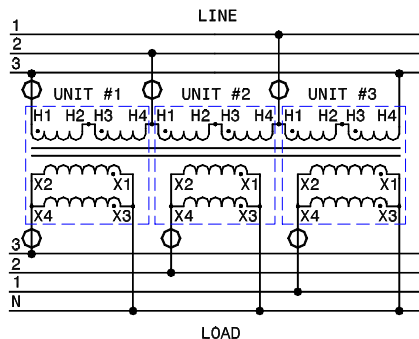

480 Δ, 208Y/120, 3 Phase - 3 Unit Bank

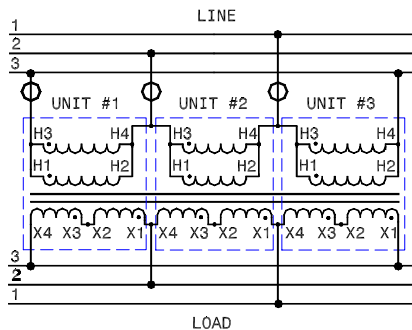

240 Δ, 240 Δ, 3 Phase - 3 Unit Bank

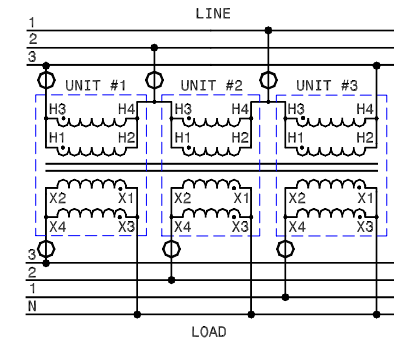

240 Δ, 208Y/120, 3 Phase - 3 Unit Bank





## Three Phase - Specialty Applications

# THREE PHASE OPEN DELTA AUTOTRANSFORMER CONNECTIONS

Single phase, general purpose transformers may be used to achieve a wide variety of nonstandard voltage combinations. These combinations are achieved by connecting two identical, 240/480 volt primary, 120 x 240 volt secondary, single phase transformers into three phase, autotransformer banks - much like the buck-boost configurations featured on pages 48 - 66 later in this catalog.

The configurations shown represent some of the more popular combinations. Many other combinations are available. Please consult the factory to obtain information on any configuration not shown in the charts below.

Dongan will provide easy to read connection diagrams at your request. Contact Dongan Customer Service at the number below and request the appropriate diagram # from chart for your application.

General Information			Pri. Volts - 480 Sec. Volts - 380				Pri. Volts - 600 Sec. Volts - 480				Pri. Volts - 600 Sec. Volts - 240			
kVA Cap.	Catalog Number	Qty. Req'd	Maximum Amps		Bank KVA	Conn. Dia. No.	Maximum Amps		Bank KVA	Conn. Dia. No.	Maximum Amps		Bank KVA	Conn. Dia. No.
			480	380			600	480			600	240		
.500	85-1025SH*	2	4.0	5.0	3.3	Dia-2034	4.2	5.2	4.3	Dia-2038	1.4	3.5	1.5	Dia-2031
.750	85-1030SH*	2	6.0	7.0	4.9	Dia-2034	6.3	7.8	6.5	Dia-2038	2.1	5.2	2.2	Dia-2031
1	85-1035SH*	2	8.0	10.0	6.6	Dia-2034	8.3	10.4	8.6	Dia-2038	2.8	7.0	2.9	Dia-2031
1.5	85-1040SH*	2	12.0	15.0	9.9	Dia-2034	12.5	15.6	13.0	Dia-2038	4.2	10.4	4.3	Dia-2031
2	85-1045SH*	2	16.0	20.0	13.0	Dia-2034	16.6	20.8	17.3	Dia-2038	5.6	14.0	5.8	Dia-2031
3	85-1050SH*	2	24	30	19.7	Dia-2034	25	31	25.9	Dia-2038	8	21	8.7	Dia-2031
5	85-1055SH*	2	40	49	32.9	Dia-2034	41	52	43.2	Dia-2038	14	35	14.5	Dia-2031
7.5	85-1060SH*	2	60	74	49.4	Dia-2034	62	78	64.8	Dia-2038	21	52	21.7	Dia-2031
10	61-1465SH	2	79	99	65.8	Dia-2035	83	104	86.4	Dia-2039	28	70	29.0	Dia-2032
15	61-1470SH	2	120	152	100	Dia-2035	125	156	129	Dia-2039	41	103	43	Dia-2032
25	61-1475SH	2	198	251	165	Dia-2035	208	260	216	Dia-2039	69	174	72	Dia-2032
37.5	61-1680SH	2	301	380	250	Dia-2036	312	390	325	Dia-2040	104	261	108	Dia-2033
50	61-1685SH	2	397	501	330	Dia-2036	416	520	432	Dia-2040	139	344	144	Dia-2033
75	61-1690SH	2	601	760	500	Dia-2036	625	780	650	Dia-2040	209	522	216	Dia-2033
100	61-1695SH	2	794	1003	660	Dia-2036	832	1040	865	Dia-2040	278	695	289	Dia-2033

General Information			Pri. Volts - 380 Sec. Volts - 240				Pri. Volts - 480 Sec. Volts - 240				Pri. Volts - 575 Sec. Volts - 480			
kVA Cap.	Catalog Number	Qty. Req'd	Maximum Amps		Bank KVA	Conn. Dia. No.	Maximum Amps		Bank KVA	Conn. Dia. No.	Maximum Amps		Bank KVA	Conn. Dia. No.
			380	240			480	240			575	480		
.500	85-1025SH*	2	4.0	6.3	2.6	Dia-4411	2.0	4.0	1.7	Dia-3080	4.3	5.2	4.3	Dia-4264
.750	85-1030SH*	2	6.0	9.4	4.0	Dia-4411	3.1	6.2	2.6	Dia-3080	6.4	7.7	6.4	Dia-4264
1	85-1035SH*	2	8.0	12.5	5.3	Dia-4411	4.1	8.2	3.4	Dia-3080	8.6	10.3	8.5	Dia-4264
1.5	85-1040SH*	2	12.5	19.0	8.0	Dia-4411	6.2	12.4	5.1	Dia-3080	12.8	15.2	12.5	Dia-4264
2	85-1045SH*	2	14.0	23.0	9.5	Dia-4411	8.2	16.4	6.8	Dia-3080	17.2	20.6	17	Dia-4264
3	85-1050SH*	2	21	34	14	Dia-4411	12	24	10	Dia-3080	25	31	26	Dia-4264
5	85-1055SH*	2	35	56	24	Dia-4411	20	40	17	Dia-3080	43	51.5	43	Dia-4264
7.5	85-1060SH*	2	53	84	35	Dia-4411	31	62	26	Dia-3080	62	75	62	Dia-4264
10	61-1465SH	2	72	114	47	Dia-4103	41	82	34	Dia-3081	82	100	85	Dia-4112
15	61-1470SH	2	106	168	70	Dia-4103	62	124	51	Dia-3081	124	150	125	Dia-4112
25	61-1475SH	2	178	280	117	Dia-4103	102	204	85	Dia-3081	204	244	210	Dia-4112
37.5	61-1680SH	2	265	420	175	Dia-4412	153	306	128	Dia-3082	306	367	320	Dia-2040
50	61-1685SH	2	350	555	230	Dia-4412	205	410	170	Dia-3082	410	492	425	Dia-2040
75	61-1690SH	2	530	840	350	Dia-4412	310	620	258	Dia-3082	620	744	638	Dia-2040
100	61-1695SH	2	700	1100	460	Dia-4412	415	830	344	Dia-3082	830	995	850	Dia-2040

Connection diagrams furnished upon request. Please consult the factory, or your Dongan Representative, to obtain the correct diagram for your specific application.

Dimensional information may be found in the single phase section of this catalog. Please be sure to order two (2) single phase units for the three phase applications listed on this page. Untapped versions, indicated by an asterisk (\*), may have output voltages varying by approximately 5% higher or lower than indicated.

Dimensions & weights may change. Consult factory for certified drawings.

DONGAN ELECTRIC MANUFACTURING CO. • 2987 FRANKLIN • DETROIT, MI 48207  
800.428.2626 • 313.567.8500 • FAX 313.567.8828 • www.dongan.com

## SERIES ODY - FACTORY PRE-CONNECTED AUTOTRANSFORMERS

Series ODY Autotransformers offer a fast, economical, factory pre-connected installation for transforming three phase lines from 208 to 240, or from 240 to 208. Simply bring in three wires on the

line side and take out three wires on the load side. Series ODY offer an economical method of bucking and boosting 208 and 240 volt lines where the presence of a fourth wire neutral is not needed.

General Information				Winding Specifications				Dimensions		
kVA Cap.	Catalog Number	Hz.	Wgt. Lbs	Taps	Maximum Amps		Conn Dia.	Height A	Width B	Depth C
					208	240				
2.8	34-280-ODY	60	21	0	7.8	6.7	ODY	10.75	4.50	4.06
5.6	34-560-ODY	60	37	0	15.6	13.5	ODY	12.25	5.31	4.75
8.4	34-840-ODY	60	54	0	23.4	20.2	ODY	15.50	5.31	4.75
11.2	84-1120-ODY	60	55	0	31.2	27.0	ODY	15.50	5.31	4.75
16.9	84-1690-ODY	60	65	0	46.8	40.5	ODY	16.13	7.19	5.81
22.5	84-2250-ODY	60	74	0	62.4	54.1	ODY	17.13	7.19	5.81
33.0	84-3300-ODY	60	127	0	93.6	81.1	ODY	20.50	7.69	6.75
56.0	84-5600-ODY	60	158	0	156.1	135.3	ODY	24.88	7.69	6.75

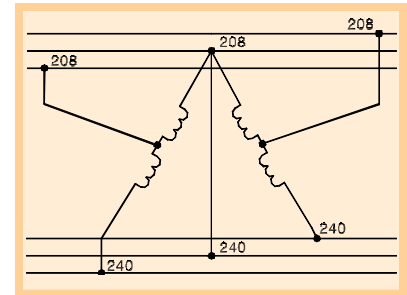

Wiring Diagram - ODY

## SERIES 3PTT

Series 3PTT Three Phase Auto Testing Transformers allow three phase line voltages to be transformed into various three phase voltages found around the world. Manufacturers, motor rewinders, machinery builders, and automation suppliers will find these versatile autotransformers particularly useful in testing motors and other loads at their rated voltage.

Voltages include 208, 220, 240, 380, 440, 480, 550, and 600 volts three phase. All taps are designed to carry full load current at rated voltage. All 3PTT Series transformers are copper wound. All units incorporate a 200°C insulation system and a 115°C rise for significant overload capacity. All are UL Listed in File E78234 and CSA Certified in File LR560.

General Information				Winding Specifications										Dimensions				
kVA Cap.	Catalog Number	Hz.	Wgt. Lbs	Taps	Maximum Amps										Conn Dia.	Height A	Width B	Depth C
					208	220	240	380	440	480	550	600						
5	84-500-3PTT	50/60	70	0	13	13	12	7	6	6	5	4	3PTT	11.50	15.50	7.75		
10	84-1000-3PTT	50/60	150	0	27	26	24	15	13	12	10	9	3PTT	21.88	25.00	18.13		
15	84-1500-3PTT	50/60	180	0	41	39	36	22	19	18	15	14	3PTT	21.88	25.00	18.13		
25	84-2500-3PTT	50/60	350	0	69	65	60	38	32	30	26	24	3PTT	29.00	24.25	20.88		
37	84-3750-3PTT	50/60	430	0	104	98	90	57	49	45	39	36	3PTT	29.00	24.25	20.88		
50	84-5000-3PTT	50/60	550	0	138	131	120	76	65	60	52	48	3PTT	29.00	24.25	20.88		
75	84-7500-3PTT	50/60	650	0	208	197	180	114	98	90	78	72	3PTT	32.00	27.25	26.25		
100	84-10000-3PTT	50/60	780	0	277	262	240	152	131	120	105	96	3PTT	32.00	27.25	26.25		

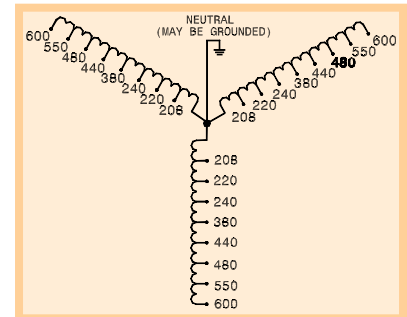

Wiring Diagram - 3PTT

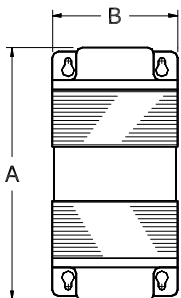

Series ODY

Wall Mount - Ventilated - NEMA 3R

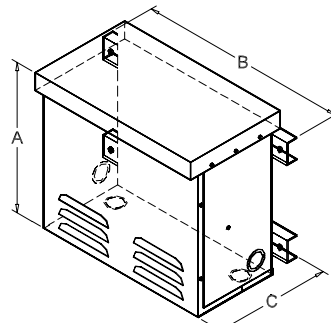

Series 3PTT, 5 - 15 kVA

Wall Mount - Ventilated - NEMA 3R

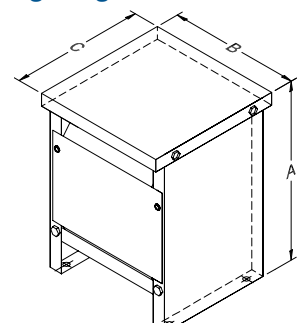

Series 3PTT, 25 - 100 kVA

Floor Mount - Ventilated - NEMA 3R

Dimensions & weights may change. Consult factory for certified drawings.

## Three Phase - Specialty Applications

### ZIG-ZAG CONNECTED AUTOTRANSFORMERS

For developing a neutral from a three phase, 3-wire supply

Three, single phase isolation transformers may be connected into a three phase "zig-zag" bank to obtain 277 volts by creating a neutral from an existing 480 volt, three phase, three wire service. This neutral can be grounded, allowing a ground fault on any phase to trip the overcurrent protection. The zig-zag connection stabilizes the neutral point so that 277 volts will be maintained between each phase and neutral under unbalanced load conditions, and also accurately reflects any ground fault condition back to the supply overcurrent protection.

**The bank's connections require three identical single phase transformers, each having a 240 x**

**480 volt primary and a 120 / 240 volt secondary.**

The chart below indicates kVA and ampere ratings for zig-zag banks of three transformers each. For example, when three 5 kVA transformers are connected per the connection diagram below, the resultant bank provides 17.3 kVA per phase, or 51.9 kVA for the bank. In this example, 17.3 kVA equals the maximum continuous load per phase at 277 volts.

In addition to providing a solution utilizing off-the-shelf transformers, the zig-zag bank is extremely economical when compared to a conventional three phase isolation transformer of similar capacity.

General Information				Winding Specifications			Dimensions		
kVA Cap.	Catalog Number	Hz.	Qty. Req'd	Maximum Per Phase		Total Bank kVA	Height A	Width B	Depth C
				kVA	Amps				
.50	85-1025SH	50 / 60	3	1.7	6.3	5.1	12.00	4.88	5.25
.75	85-1030SH	50 / 60	3	2.6	9.3	7.7	12.00	4.88	5.25
1.0	85-1035SH	60	3	3.5	12.5	10.5	15.25	5.75	5.88
1.5	85-1040SH	60	3	5.2	18.8	15.6	15.25	5.75	5.88
2.0	85-1045SH	60	3	6.9	25.0	20.7	15.25	5.75	5.88
3.0	85-1050SH	60	3	10.4	37.5	31.2	15.25	8.25	7.88
5.0	85-1055SH	60	3	17.3	62.5	51.9	15.25	8.25	7.88
7.5	85-1060SH	60	3	26	94	78	15.75	14.25	8.75
10	61-1465SH	60	3	34.6	125	105	22.00	16.00	14.00
15	61-1470SH	60	3	52	187.5	156	23.50	18.63	16.00
25	61-1475SH	60	3	86	312	261	23.50	18.63	16.00
37.5	61-1680SH	60	3	130	468	390	32.00	27.00	26.25
50	61-1685SH	60	3	173	625	519	32.00	27.00	26.25
75	61-1690SH	60	3	260	935	780	41.00	34.00	26.75
100	61-1695SH	60	3	346	1250	1038	41.00	34.00	26.75

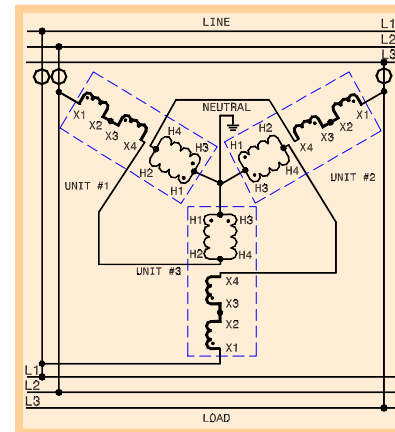

(O Indicates Overcurrent Protection)

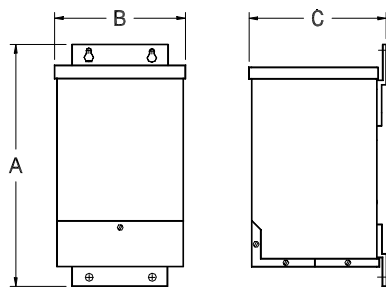

.5 kVA to 5 kVA

Wall Mount - Encapsulated - NEMA 3R

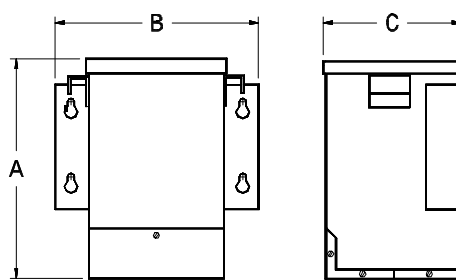

7.5 kVA

Wall Mount - Encapsulated - NEMA 3R

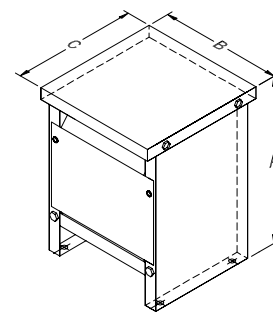

10 kVA to 100 kVA

Floor Mount - Ventilated - NEMA 3R

Connection diagrams furnished upon request. Please consult the factory, or your Dongan Representative, to obtain the correct diagram for your specific application.

Dimensional information may be found in the single phase section of this catalog. Please be sure to order two (3) single phase units for the three phase applications listed on this page.

## Outline Drawings

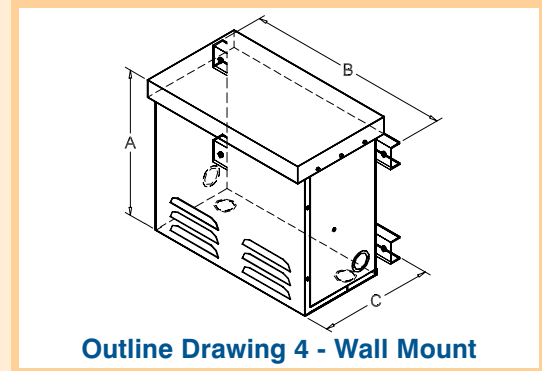
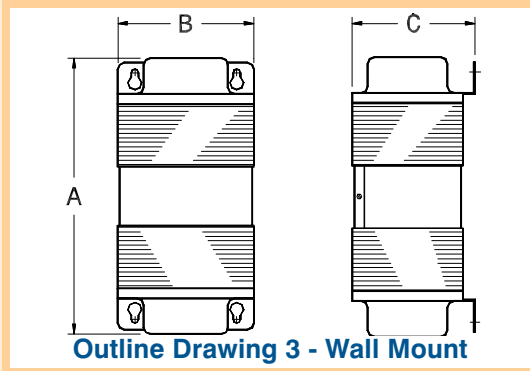
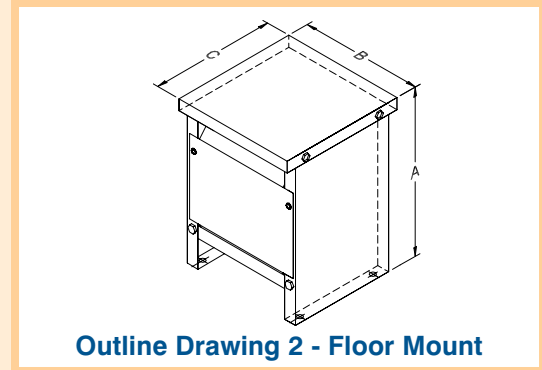
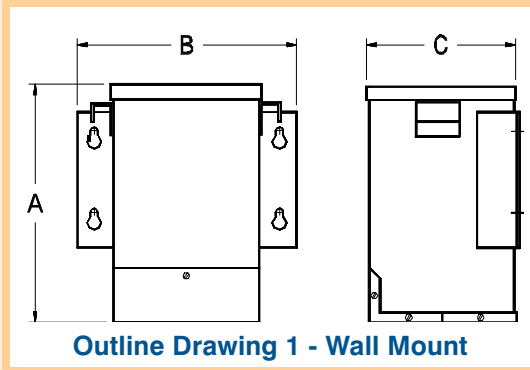

## Wall Mounting Brackets - Three Phase 15 kVA - 75 kVA

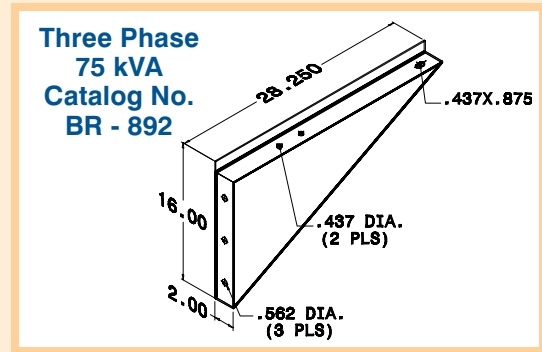
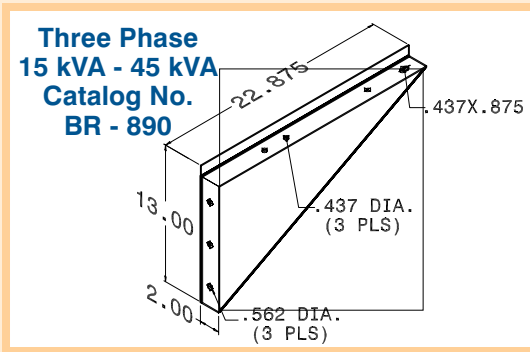

## Buck - Boost Transformers

### Contents

Buck - Boost Transformers - Terms & Definitions .....	48
Buck - Boost Transformers - Sizing .....	50
Quick Reference Chart - 208, 230, 240 Volts Single & Three Phase .....	52
Single Phase Buck - Boost Sizing Tables .....	53
Three Phase Buck - Boost Sizing Tables .....	56
Buck - Boost Connection Diagrams .....	59
Encapsulated Buck - Boost Transformers .....	64
Ventilated Buck - Boost Transformers .....	65
Series ODY Buck - Boost Transformers .....	66

DONGAN ELECTRIC MANUFACTURING Co. • 2987 FRANKLIN • DETROIT, MI 48207  
 800.428.2626 • 313.567.8500 • Fax 313.567.8828 • www.dongan.com

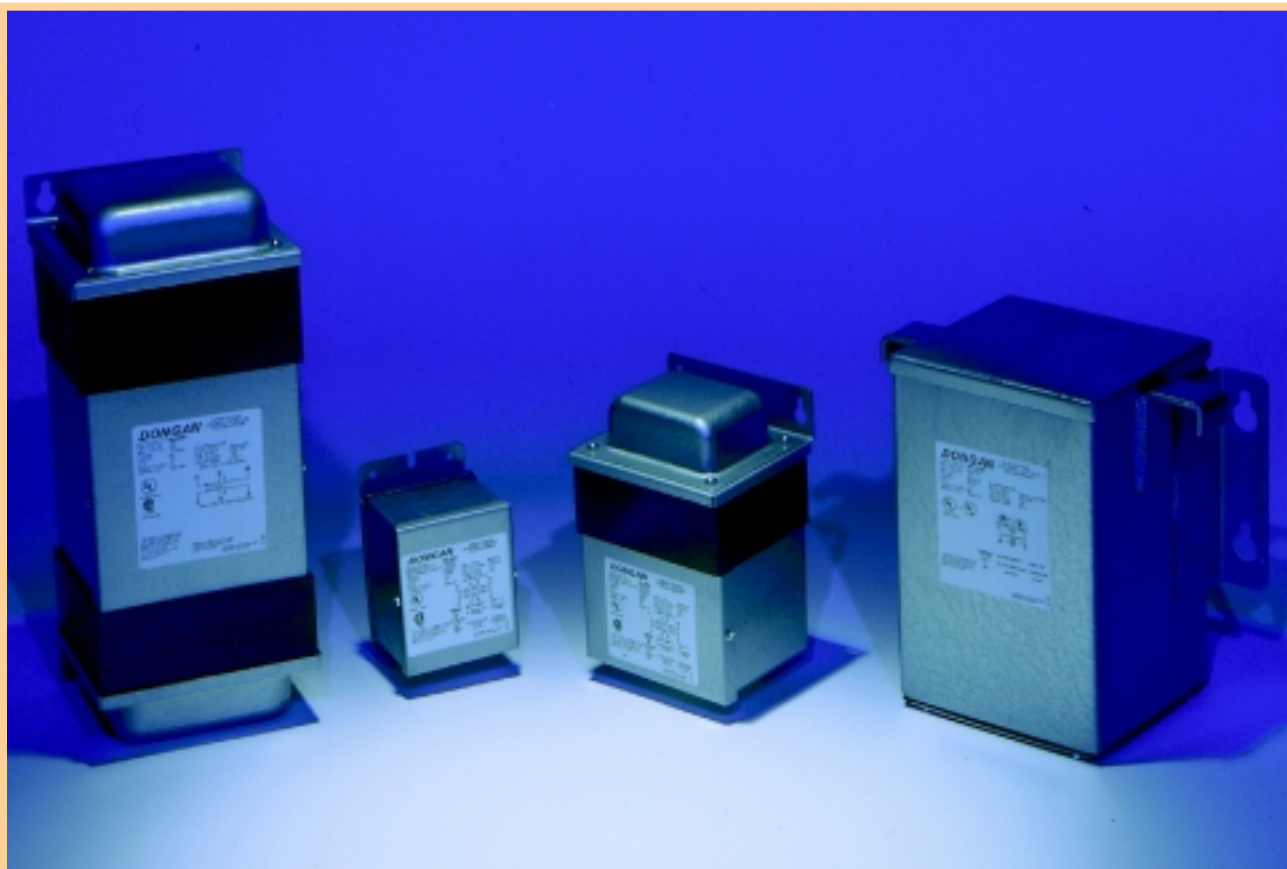



## Buck - Boost Transformer Terms & Definitions

DONGAN ELECTRIC MANUFACTURING CO. • 2987 FRANKLIN • DETROIT, MI 48207  
800.428.2626 • 313.567.8500 • FAX 313.567.8828 • www.dongan.com

Buck-Boost transformers are single phase, four winding transformers designed for two purposes. The first purpose is as a low voltage isolation transformer for use on 12, 16, 24, 32, or 48 volt circuits. When used as low voltage transformers, Buck-Boost transformers have capacities of .050 kVA to 5.0 kVA. Their second, and more important use, is as a "Buck-Boost" transformer. Buck-Boost means that these transformers are used to buck (lower) or boost (increase) line voltage to match required load voltage.

Buck-Boost transformers are used to correct consistently low or high voltage conditions, where the voltage difference ranges from approximately 5% to 27%. Variation of the input voltage is passed through to the output side of the transformer in the same percentage. This concept is important because the question is frequently asked if Buck-Boost transformers will stabilize variable voltages. They will not!

Low voltage conditions may be found at the end of long wire runs where a line voltage drop has occurred due to resistance in the wire. While high voltage supply lines are less frequent, they may be found close to voltage distribution points. Buck-Boost transformers offer a simple, economical solution to these common voltage problems and mitigate the harmful heating effects of low or high voltage.

Buck-Boost transformers are typically four winding isolation transformers as they leave the factory. Connected as an isolation transformer, these products may be used for many low voltage applications such as low voltage control panels or indoor/outdoor low voltage lighting. Low voltage connection charts may be found on Page 66. Type M, Type Y, and Type LM transformers connected per these charts are isolating type transformers.

When connected as a Buck Boost transformer, these transformers, with dual primaries of 120 x 240, or 240 x 480, and dual secondaries of 12 / 24, 16 / 32, or 24 / 48 volts, have literally hundreds of voltage matching applications.

Buck-Boost connections result when a lead(s) from the primary winding is interconnected to a lead(s) from the secondary winding. This interconnection modifies the transformer from an isolation transformer into an autotransformer because the primary and secondary windings are no longer electrically isolated from each other. This distinction is depicted in the diagrams below.

When used in this fashion, the Buck-Boost transformer's kVA capacity is substantially greater than when connected as a low voltage, isolation transformer, as a portion of the line current flows directly through to the connected load.

Buck-Boost transformers are simple and straight forward to specify, size and connect. Buck-Boost connections are achieved by interconnecting the 8 copper lead wires supplied with each transformer in accordance with the charts contained in this section. In addition, each transformer shipped from the factory is equipped with a similar chart to assure ease of use at the installation site.

### Applications:

The most common applications for these transformers are boosting 208 volt lines to 230 or 240 volts, and vice-versa. These applications include both single and three phase lines and are particularly common in HVAC applications for air-conditioning appliances. A chart is specifically provided for convenient sizing of these applications on page 52.

Additionally, Buck-Boost transformers are very well suited to motor loads, boosting 240 to 277 for lighting loads and many applications where nominal voltage is above or below 120 volts. Their use should be considered where supply line voltage is found to be consistently above or below desired nominal values of load voltage.

### Single Phase Applications:

Single phase applications require the purchase of one transformer. Charts are provided on Pages 53 - 55 for sizing and specifying single phase applications.

### Three Phase Applications:

Three phase applications require banking either 2 or 3 Buck-Boost transformers. Charts are provided on Pages 56 - 58 for sizing and specifying three phase applications.

Series ODY Autotransformers provide an economical, factory preconnected installation for transforming three phase lines from 208 to 240, or 240 to 208. This series banks 2 Buck-Boost transformers into one assembly for mounting and one assembly for connecting. Simply bring in three wires on the line side and take out three wires on the load side.

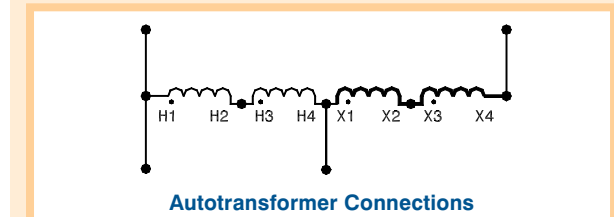
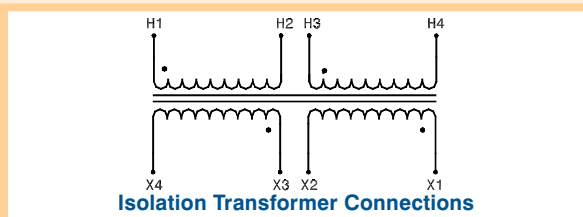

# Buck - Boost Transformer Terms & Definitions

## Connection/Configurations to Avoid:

Some line/load distribution system combinations are to be avoided. For instance, closed delta connections are not recommended because they may cause phase shifting to occur on the load side of the bank. In addition, they require larger transformers to accomplish similar results and are, therefore, less efficient and more expensive. Also, a three phase, 4 wire wye supply line should be connected to a wye configuration, 3 transformer bank. This configuration will assure sufficient current carrying capacity in the neutral of the wye circuit.

The chart below indicates distribution system restrictions.

Input (Supply System)	Desired Output Connection	
WYE 4 wire	WYE 3 or 4 wire	OK
WYE 3 or 4 wire	OPEN DELTA 3 wire	OK
CLOSED DELTA 3 Wire	OPEN DELTA 3 wire	OK
DELTA 3 Wire	WYE 3 or 4 wire	DO NOT USE
OPEN DELTA 3 wire	WYE 3 or 4 wire	DO NOT USE
WYE 3 or 4 wire	CLOSED DELTA 3 Wire	DO NOT USE

## Fusing Buck-Boost Transformers:

Buck-Boost kVA capacity is significantly higher than the low voltage isolation capacity listed on the nameplate of the transformer. Frequently, this disparity leads to questions of how to fuse the transformer. The Buck-Boost sizing charts on the following pages conveniently provide a fuse size for each transformer application.

In addition, paragraph 450-4 of the *National Electric Code*® provides more detailed information:

### 450-4. Autotransformers 600 Volts, Nominal, or Less.

- (a) Overcurrent Protection. Each autotransformer 600 volts, nominal, or less, shall be protected by an individual overcurrent device installed in series with each ungrounded input conductor. Such overcurrent device shall be rated or set at not more than 125 percent of the rated full-load input current of the autotransformer. An overcurrent device shall not be installed in series with the shunt winding (the winding common to both the input and the output circuits) of the

autotransformer between Points A and B as shown in Figure 450-4.

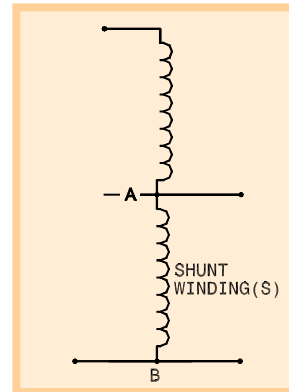
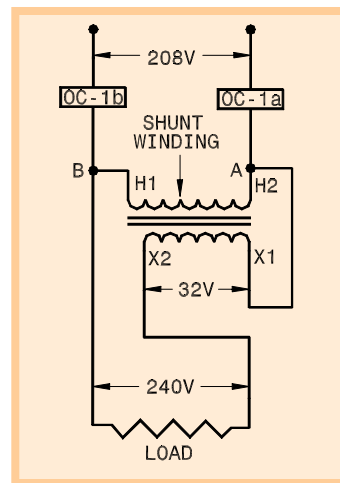

Figure 450-4

*Exception:* Where the rated input current of an autotransformer is 9 amperes or more and 125 percent of this current does not correspond to a standard rating of a fuse or nonadjustable circuit breaker, the next higher standard rating described in Section 240-6 (NEC) shall be permitted. Where the rated input current is less than 9 amperes, an overcurrent device rated or set at not more than 167 percent of the input current shall be permitted.



The drawing above indicates proper overcurrent placement in a typical Buck-Boost application.

- (b) Transformer Field-Connected as an Autotransformer. A transformer field-connected as an autotransformer shall be identified for use at elevated voltage.

Reprinted with permission from NFPA 70-1996, The *National Electrical Code*®, Copyright© 1995, National Fire Protection Association, Quincy, MA 02269. This reprinted material is not the complete and official position of the National Fire Protection Association on the referenced subject, which is represented only by the standard in its entirety.

## Sizing Buck-Boost Transformers:

Please turn to the next page for the proper questions to ask when sizing these installations. Sizing will be self evident when the examples are followed.



## Buck - Boost Transformer - Sizing

DONGAN ELECTRIC MANUFACTURING CO. • 2987 FRANKLIN • DETROIT, MI 48207  
 800.428.2626 • 313.567.8500 • FAX 313.567.8828 • www.dongan.com

Determine the information below in order to select the correct buck- boost transformer for your application. Reference tables, sizing formulae, kVA, amps, and motor horsepower are provided on the

following page. Any questions on sizing may be handled by your Dongan Representative or by contacting Dongan Customer Service at ( 800 ) 428-2626.

Required Data	Explanation:	Examples	
		Single Phase	Three Phase
<b>Phase Requirements</b>	Determine load phase requirements <ul style="list-style-type: none"> <li>• Single phase</li> <li>• Three phase</li> </ul>	<b>1 Phase</b>	<b>3 Phase</b>
<b>Line Voltage</b>	Determine the supply or line voltage at the installation site where the transformer will be connected. This is best accomplished by measuring the voltage with a suitable voltmeter.	<b>106 volts</b>	<b>208 volts</b>
<b>Load Voltage</b>	Determine the voltage you require to operate the load to be connected to the transformer. If you are unsure of the correct voltage, check the nameplate of the devices intended for operation.	<b>120 volts</b>	<b>240 volts</b>
<b>Frequency</b>	Be certain the supply line frequency and the load frequency required are the same. Remember: a transformer is not capable of changing frequency.	<b>60 Hz</b>	<b>60 Hz</b>
<b>Load Amps or kVA</b>	Determine either load kVA or load amps by adding all loads to be supplied by the transformer. This is best accomplished by again referring to the equipment nameplates.	<b>4 kVA</b>	<b>15 kVA</b>
<b>Select Correct Catalog No. from Charts</b>	<p>Now turn to the appropriate single or three phase buck - boost chart. Select the column closest to the line/load voltage combination for your application. Move down the column until values of load kVA or load amps meet or exceed your load amps or load kVA required. Never size smaller than your requirements demand. Then read across the row to select the correct catalog number for your application.</p> <p>Remember, three phase applications require banks of two or three transformers, while single phase applications require only one unit. The charts note the correct combination of units required at the bottom of the columns. Be sure to specify and order the correct number of units for your three phase applications.</p>	<b>Cat No. 85-Y030 or 35-Y030 1 Unit Required</b>	<b>Cat No. 85-Y040 or 80-Y040 2 Units Required</b>
<b>Connect Transformer per Supplied Diagrams</b>	The transformer may now be connected per the diagram indicated at the bottom of the column from which you selected your line/load combination. A connection diagram is packaged with each Buck-Boost transformer for your convenience.	<b>Diagram SP-11</b>	<b>Diagram TP-5</b>

# Buck - Boost Sizing Data

## HOW TO DETERMINE TRANSFORMER kVA RATINGS

### Transformer Load expressed in amperes:

Select the appropriate kVA size from the selection charts listed on this page or by using the single phase or three phase sizing formula listed below. Be sure to select a transformer kVA rating equal to or greater than the anticipated connected load.

$$\text{Single Phase kVA} = \frac{\text{Load Voltage} \times \text{Load Amps}}{1000} \quad \text{kVA} = \frac{\text{Volt Amperes}}{1000}$$

$$\text{Three Phase kVA} = \frac{\text{Load Voltage} \times \text{Load Amps} \times 1.73}{1000} \quad \text{VA} = \text{kVA} \times 1000$$

### Transformer Load expressed in kVA:

Select the appropriate size from the selection charts. Be sure to select a transformer kVA rating equal to or greater than the anticipated connected load.

### Transformer Load expressed in wattage:

Convert wattage into a kVA rating by using the formula listed below. Or you may refer to the equipment nameplate to obtain the ampere requirements of the connected load. Be sure to select a transformer kVA rating equal to or greater than the anticipated connected load.

$$\text{kVA} = \frac{\text{Wattage}}{(1000 \times \text{Power Factor of the Load})}$$

### Transformer Load expressed in motor horsepower:

Select the appropriate size kVA rating from the motor horsepower charts on this page. Be sure to select a transformer kVA rating equal to or greater than the anticipated load requirements.

#### Note:

**High Ambient Temperature Applications:** Derate the transformer nameplate kVA 8% for each 10°C above 40°C up to 60°C. Consult factory for ambients above 60°C.

**High Altitude Applications:** To allow for reduced cooling at higher elevations derate the transformer nameplate kVA by .3% for each 330 feet over 3300 feet above sea level.

kVA / Ampacity Ratings for Single Phase AC Voltages													
kVA	12V	16V	24V	32V	48V	120V	208V	240V	277V	380V	415V	480V	600V
.050	4.2	3.1	2.1	1.6	1.0	.42	.24	.21	.18	.13	.12	.10	.08
.100	8.3	6.2	4.2	3.3	2.0	.83	.48	.42	.36	.26	.24	.21	.17
.150	12.5	9.4	6.3	4.6	3.1	1.3	.72	.63	.54	.39	.36	.31	.25
.250	20.8	15.6	10.4	7.8	5.2	2.1	1.2	1.0	.90	.66	.60	.52	.42
.500	41.7	31.2	20.8	15.6	10.4	4.2	2.4	2.1	1.8	1.3	1.2	1.0	.83
.750	62	47	31.3	23.4	16.6	6.3	3.6	3.1	2.7	2.0	1.8	1.6	1.3
1	83	62	41.7	31.2	20.8	8.3	4.8	4.2	3.6	2.6	2.4	2.1	1.7
1.5	125	94	62	47	31.2	12.5	7.2	6.3	5.4	3.9	3.6	3.1	2.5
2	166	125	83	62.5	41.6	16.7	9.6	8.3	7.2	5.3	4.8	4.2	3.3
3	250	188	125	94	62	25.0	14.4	12.5	10.8	7.9	7.2	6.3	5.0
5	416	312	208	156	104	41.7	24.0	20.8	18.1	13.2	12.0	10.4	8.3
7.5						62	36.1	31.3	27.1	19.7	18.1	15.6	12.5
10						83	48.1	41.7	36.1	26.3	24.1	20.8	16.7
15						125	72	62	54	39.5	36.1	31.3	25.0
25						208	120	104	90	65	60	52	41.7
37.5						312	180	156	135	98	90	78	62
50						416	240	208	180	131	120	104	83
75						625	360	312	270	197	180	156	125
100						833	480	416	361	263	240	208	166

kVA / Ampacity Ratings for Three Phase AC Voltages								
kVA	200V	208V	240V	380V	415V	480V	575V	600V
3	8.6	8.3	7.2	4.5	4.1	3.6	3.0	2.8
6	17.3	16.6	14.4	9.1	8.3	7.2	6.0	5.7
9	26.0	25.0	21.6	13.6	12.5	10.8	9.0	8.6
15	43.3	41.6	36.1	22.8	20.8	18.0	15.0	14.4
25	72	69	60	38.0	34.8	30.1	25.1	24.0
30	86	83	72	45.6	41.7	36.1	30.1	28.9
45	130	125	108	68	62	54	45.2	43.3
75	216	208	180	114	104	90	75	72
112.5	325	312	270	171	156	135	113	108
150	433	416	361	228	208	180	150	144

Full Load Amperes - Single Phase AC Motor Voltages						
HP	115V	200V	208V	230V	Minimum Transformer kVA	Std. Dongan Size
1/6	4.4	2.5	2.4	2.2	.53	.750
1/4	5.8	3.3	3.2	2.9	.70	.750
1/3	7.2	4.1	4.0	3.6	.87	1
1/2	9.8	5.6	5.4	4.9	1.18	1.5
3/4	13.8	7.9	7.6	6.9	1.68	2
1	16	9.2	8.8	8	1.92	2
1 1/2	20	11.5	11	10	2.40	3
2	24	13.8	13.2	12	2.88	3
3	34	19.6	18.7	17	4.10	5
5	56	32.2	30.8	28	6.72	7.5
7 1/2	80	46	44	40	9.60	10
10	100	57.5	55	50	12.0	15

Full Load Amperes - Three Phase AC Motor Voltages						
HP	208V	230V	460V	575V	Min. Transformer kVA	Std. Dongan Size
1/2	2.4	2.2	1.1	.9	0.9	3
3/4	3.5	3.2	1.6	1.3	1.2	3
1	4.6	4.2	2.1	1.7	1.5	3
1 1/2	6.6	6.0	3.0	2.4	2.1	3
2	7.5	6.8	3.4	2.7	2.7	3
3	10.6	9.6	4.8	3.9	3.8	6
5	16.7	15.2	7.6	6.1	6.3	9
7 1/2	24.2	22	11	9	9.2	15
10	30.8	28	14	11	11.2	15
15	46.2	42	21	17	16.6	25
20	59.4	54	27	22	21.6	25
25	74.8	68	34	27	26.6	30
30	88	80	40	32	32.4	45
40	114	104	52	41	43.2	45
50	143	130	65	52	52	75
60	169	154	77	62	64	75
75	211	192	96	77	80	112.5
100	273	248	124	99	103	112.5
125	343	312	156	125	130	150
150	396	360	180	144	150	150

#### Note:

Increase transformer kVA by 20% when motors are started more than once per hour.

Multiply motor ampacity by 1.1 and 1.25 respectively for 90% and 80% power factors.





# Quick Reference Chart - 208, 230, 240 Volts Single & Three Phase Buck - Boost

DONGAN ELECTRIC MANUFACTURING CO. • 2987 FRANKLIN • DETROIT, MI 48207  
 800.428.2626 • 313.567.8500 • FAX 313.567.8828 • www.dongan.com

The most common buck - boost transformer uses are those involving line / load combinations of 208, 230 and 240 volts, in both single and three phase installations. These applications include air conditioning loads, motor loads, and machinery loads of all kinds.

The charts below provide simple solutions to these common applications with easy access data for kVA, line, and load amps information.

Three phase installations are easily accomplished with the use of Series ODY factory preconnected three phase buck boost transformers. The ODY Series allows you to *install and connect one preconnected transformer* for your three phase applications.

Other voltage combinations may be found on the following pages.

Single Phase			Single Phase		
Type M - 1 Unit			Type Y - 1 Unit		
Catalog Number	230		Catalog Number	240	
	208			208	
35-M005 .45 kVA	Max Amps at 230 V.	1.9	35-Y005 .37 kVA	Max Amps at 240 V.	1.5
	Max Amps at 208 V.	2.1		Max Amps at 208 V.	1.8
	208V Fuse	5		208V Fuse	5
35-M010 .90 kVA	Max Amps at 230 V.	3.9	35-Y010 .75 kVA	Max Amps at 240 V.	3.1
	Max Amps at 208 V.	4.3		Max Amps at 208 V.	3.6
	208V Fuse	8		208V Fuse	5
35-M015 1.36kVA	Max Amps at 230 V.	5.9	35-Y015 1.12 kVA	Max Amps at 240 V.	4.6
	Max Amps at 208 V.	6.5		Max Amps at 208 V.	5.4
	208V Fuse	12		208V Fuse	8
85-M020 2.2 kVA	Max Amps at 230 V.	9.8	85-Y020 1.8 kVA	Max Amps at 240 V.	7.5
	Max Amps at 208 V.	10.8		Max Amps at 208 V.	9.0
	208V Fuse	15		208V Fuse	15
85-M025 4.5 kVA	Max Amps at 230 V.	19.7	85-Y025 3.7 kVA	Max Amps at 240 V.	15.4
	Max Amps at 208 V.	21.7		Max Amps at 208 V.	18.0
	208V Fuse	30		208V Fuse	25
85-M030 6.7 kVA	Max Amps at 230 V.	29.5	85-Y030 5.6 kVA	Max Amps at 240 V.	23.3
	Max Amps at 208 V.	32.6		Max Amps at 208 V.	27.0
	208V Fuse	45		208V Fuse	30
85-M035 9.0 kVA	Max Amps at 230 V.	39.4	85-Y035 7.5 kVA	Max Amps at 240 V.	31.2
	Max Amps at 208 V.	43.5		Max Amps at 208 V.	36.0
	208V Fuse	60		208V Fuse	40
85-M040 13.5 kVA	Max Amps at 230 V.	59.1	85-Y040 11.2 kVA	Max Amps at 240 V.	46.6
	Max Amps at 208 V.	64.9		Max Amps at 208 V.	54.0
	208V Fuse	90		208V Fuse	60
85-M045 18.1 kVA	Max Amps at 230 V.	78.8	85-Y045 15.0 kVA	Max Amps at 240 V.	62.5
	Max Amps at 208 V.	87.0		Max Amps at 208 V.	72.1
	208V Fuse	125		208V Fuse	80
85-M050 27.1 kVA	Max Amps at 230 V.	118.2	85-Y050 22.5 kVA	Max Amps at 240 V.	93.7
	Max Amps at 208 V.	130.2		Max Amps at 208 V.	108.0
	208V Fuse	175		208V Fuse	125
85-M055 45.3 kVA	Max Amps at 230 V.	197.0	85-Y055 37.5 kVA	Max Amps at 240 V.	156.2
	Max Amps at 208 V.	217.7		Max Amps at 208 V.	180.2
	208V Fuse	300		208V Fuse	200
Qty. Required	1		Qty. Required	1	
Connection Dia.	SP- 14		Connection Dia.	SP- 15	
Page	60		Page	60	

Three Phase			Three Phase		
Type ODY - 1 Unit			Type Y - 2 Units		
Catalog Number	240	Max Amps	Catalog Number	240	Max Amps
	208			208	
<b>Series ODY</b>					
Autotransformers provide an economical, factory preconnected installation for transforming three phase lines from 208 to 240, or 240 to 208. Simply bring in three wires on the line side and take out three wires on the load side.					
34-280-ODY 2.8 kVA	Max Amps at 240 V.	6.7	85-Y020 2.8 kVA	Max Amps at 240 V.	6.7
	Max Amps at 208 V.	7.8		Max Amps at 208 V.	7.8
	Fuse Size	15		Fuse Size	15
34-560-ODY 5.6 kVA	Max Amps at 240 V.	13.5	85-Y025 5.6 kVA	Max Amps at 240 V.	13.5
	Max Amps at 208 V.	15.6		Max Amps at 208 V.	15.6
	Fuse Size	25		Fuse Size	25
34-840-ODY 8.4 kVA	Max Amps at 240 V.	20.2	85-Y030 8.4 kVA	Max Amps at 240 V.	20.2
	Max Amps at 208 V.	23.4		Max Amps at 208 V.	23.4
	Fuse Size	30		Fuse Size	30
84-1120-ODY 11.2 kVA	Max Amps at 240 V.	27.0	85-Y035 11.2 kVA	Max Amps at 240 V.	27.0
	Max Amps at 208 V.	31.2		Max Amps at 208 V.	31.2
	Fuse Size	45		Fuse Size	45
84-1690-ODY 16.9 kVA	Max Amps at 240 V.	40.5	85-Y040 16.9 kVA	Max Amps at 240 V.	40.5
	Max Amps at 208 V.	46.8		Max Amps at 208 V.	46.8
	Fuse Size	60		Fuse Size	60
84-2250-ODY 22.5 kVA	Max Amps at 240 V.	54.1	85-Y045 22.5 kVA	Max Amps at 240 V.	54.1
	Max Amps at 208 V.	62.4		Max Amps at 208 V.	62.4
	Fuse Size	80		Fuse Size	80
84-3300-ODY 33.7 kVA	Max Amps at 240 V.	81.1	85-Y050 33.7 kVA	Max Amps at 240 V.	81.1
	Max Amps at 208 V.	93.6		Max Amps at 208 V.	93.6
	Fuse Size	125		Fuse Size	125
84-5600-ODY 56.2 kVA	Max Amps at 240 V.	135.3	85-Y055 56.2 kVA	Max Amps at 240 V.	135.3
	Max Amps at 208 V.	156.1		Max Amps at 208 V.	156.1
	Fuse Size	200		Fuse Size	200
Qty. Required	1		Qty. Required	2	
Connection Dia.	TP-25		Connection Dia.	TP-26	
Page	63		Page	63	





# Single Phase Buck - Boost Sizing Tables

## SINGLE PHASE BUCK - BOOST TABLE, TYPE M

Type M		Single Phase / Single Unit - Type M												
Catalog Number	Load Line	Boost - Increase Voltage								Buck - Decrease Voltage				
		120	120	120	120	240	240	240	230	120	120	208	240	240
		96	100	108	109	216	218	228	208	132	144	230	252	264
35-M005	Load Amps	2.0	2.0	3.7	4.1	2.0	2.0	4.1	1.9	4.5	2.5	2.1	4.3	2.2
	kVA	0.25	0.25	0.45	0.49	0.50	0.49	1.00	0.45	0.55	0.30	0.45	1.05	0.55
	Line Fuse	5	5	8	8	5	5	7	5	7	5	5	7	5
35-M010	Load Amps	4.1	4.1	7.5	8.2	4.1	4.1	8.3	3.9	9.1	5.0	4.3	8.7	4.5
	kVA	0.50	0.50	0.90	0.99	1.00	0.99	2.00	0.90	1.10	0.60	0.91	2.10	1.10
	Line Fuse	10	10	15	15	8	8	15	8	15	7	7	15	7
35-M015	Load Amps	6.2	6.2	11.2	12.3	6.2	6.1	12.5	5.9	13.7	7.5	6.5	13.1	6.8
	kVA	0.75	0.75	1.35	1.48	1.50	1.48	3.00	1.36	1.65	0.90	1.36	3.15	1.65
	Line Fuse	15	15	20	20	12	12	20	12	20	12	10	20	12
85-M020	Load Amps	10.4	10.4	18.7	20.6	10.4	10.3	20.8	9.8	22.9	12.5	10.9	21.8	11.4
	kVA	1.25	1.25	2.25	2.47	2.50	2.47	5.00	2.26	2.75	1.50	2.27	5.25	2.75
	Line Fuse	20	20	30	30	15	15	30	15	30	15	15	30	15
85-M025	Load Amps	20.8	20.8	37.5	41.2	20.8	20.6	41.6	19.7	45.8	25.0	21.8	43.7	22.9
	kVA	2.50	2.50	4.50	4.95	5.00	4.95	10.00	4.53	5.50	3.00	4.55	10.50	5.50
	Line Fuse	35	35	60	60	30	30	60	30	60	30	30	60	30
85-M030	Load Amps	31.2	31.2	56.2	61.9	31.2	30.9	62.5	29.5	68.7	37.5	32.8	65.6	34.3
	kVA	3.75	3.75	6.75	7.43	7.50	7.43	15.00	6.79	8.25	4.50	6.83	15.75	8.25
	Line Fuse	50	50	80	90	45	45	80	45	80	40	40	80	40
85-M035	Load Amps	41.6	41.6	75.0	82.5	41.6	41.2	83.3	39.4	91.6	50.0	43.7	87.5	45.8
	kVA	5.00	5.00	9.00	9.90	10.00	9.90	20.00	9.06	11.00	6.00	9.10	21.00	11.00
	Line Fuse	70	70	125	125	60	60	110	60	110	60	60	110	60
85-M040	Load Amps	62.5	62.5	112.5	123.8	62.5	61.9	125.0	59.1	137.5	75.0	65.6	131.2	68.7
	kVA	7.5	7.5	13.5	14.8	15.0	14.8	30.0	13.5	16.5	9.0	13.6	31.5	16.5
	Line Fuse	100	100	175	175	80	80	175	90	175	80	80	175	80
85-M045	Load Amps	83.3	83.3	150.0	165.1	83.3	82.5	166.6	78.8	183.3	100.0	87.5	175.0	91.6
	kVA	10.0	10.0	18.0	19.8	20.0	19.8	40.0	18.1	22.0	12.0	18.2	42.0	22.0
	Line Fuse	150	150	250	250	125	125	225	125	225	110	110	225	110
85-M050	Load Amps	125.0	125.0	225.0	247.7	125.0	123.8	250.0	118.2	275.0	150.0	131.3	262.5	137.5
	kVA	15.0	15.0	27.0	29.7	30.0	29.7	60.0	27.1	33.0	18.0	27.3	63.0	33.0
	Line Fuse	200	200	350	350	175	175	350	175	350	175	150	350	175
85-M055	Load Amps	208.3	208.3	375.0	412.8	208.3	206.4	416.6	197.0	458.3	250.0	218.9	437.5	229.1
	kVA	25.0	25.0	45.0	49.5	50.0	49.5	100.0	45.3	55.0	30.0	45.5	105.0	55.0
	Line Fuse	350	350	600	600	300	300	600	300	600	300	250	600	300
Qty. Required Connection Dia. Page		1 SP - 8 59	1 SP -12 60	1 SP - 7 59	1 SP -11 60	1 SP - 6 59	1 SP -10 60	1 SP - 5 59	1 SP -10 60	1 SP - 3 59	1 SP - 4 59	1 SP - 2 59	1 SP -1 59	1 SP - 2 59

DONGAN ELECTRIC MANUFACTURING CO. • 2987 FRANKLIN • DETROIT, MI 48207  
 800.428.2626 • 313.567.8500 • FAX 313.567.8828 • www.dongan.com

Connection diagrams may be found on Pgs. 59 - 60.  
**Connections found on this Page require ordering 1 Buck - Boost Transformer**  
 The appropriate size 35 or 80 Series Transformer may be substituted for the 85 Series where desired.



# Single Phase Buck - Boost Sizing Tables

## SINGLE PHASE BUCK - BOOST TABLE, TYPE Y

Type Y		Single Phase / Single Unit - Type Y												
Catalog Number	Load Line	Boost - Increase Voltage								Buck - Decrease Voltage				
		120	120	120	120	240	240	240	240	120	120	240	240	208
		88	95	104	106	212	224	225	208	136	152	256	272	240
35-Y005	Load Amps	1.5	1.9	3.1	3.1	1.5	3.1	3.1	1.5	3.5	1.9	3.3	1.7	1.8
	kVA	0.18	0.23	0.37	0.37	0.37	0.75	0.75	0.37	0.42	0.23	0.80	0.42	0.37
	Line Fuse	5	5	5	5	5	5	5	5	5	5	5	5	5
35-Y010	Load Amps	3.1	3.9	6.2	6.3	3.1	6.2	6.2	3.1	7.0	3.9	6.6	3.5	3.6
	kVA	0.37	0.47	0.75	0.75	0.75	1.50	1.50	0.75	0.85	0.47	1.60	0.85	0.75
	Line Fuse	7	8	12	12	6	10	10	6	10	5	10	5	5
35-Y015	Load Amps	4.6	5.9	9.3	9.4	4.7	9.3	9.3	4.6	10.6	5.9	10.0	5.3	5.4
	kVA	0.56	0.71	1.12	1.13	1.13	2.25	2.25	1.12	1.27	0.71	2.40	1.27	1.12
	Line Fuse	10	15	15	15	9	15	15	9	15	8	15	8	8
85-Y020	Load Amps	7.8	9.8	15.6	15.7	7.8	15.6	15.6	7.8	17.7	9.8	16.6	8.8	9.0
	kVA	0.93	1.18	1.87	1.89	1.89	3.75	3.75	1.87	2.12	1.18	4.00	2.12	1.87
	Line Fuse	15	25	25	25	15	25	25	15	20	15	20	15	15
85-Y025	Load Amps	15.6	19.7	31.2	31.5	15.7	31.2	31.2	15.6	35.4	19.7	33.3	17.7	18.0
	kVA	1.87	2.37	3.75	3.78	3.78	7.50	7.50	3.75	4.25	2.37	8.00	4.25	3.75
	Line Fuse	30	35	45	45	25	45	45	25	40	25	40	25	25
85-Y030	Load Amps	23.4	29.6	46.8	47.3	23.6	46.8	46.8	23.4	53.1	29.6	50.0	26.5	27.0
	kVA	2.81	3.56	5.62	5.67	5.67	11.25	11.25	5.62	6.37	3.56	12.00	6.37	5.62
	Line Fuse	40	50	70	70	35	70	70	35	60	30	60	35	30
85-Y035	Load Amps	31.2	39.5	62.5	63.0	31.5	62.5	62.5	31.2	70.8	39.5	66.6	35.4	36.0
	kVA	3.75	4.75	7.50	7.57	7.57	15.00	15.00	7.50	8.50	4.75	16.00	8.50	7.50
	Line Fuse	60	70	90	90	45	90	90	50	80	40	80	45	40
85-Y040	Load Amps	46.8	59.3	93.7	94.6	47.3	93.7	93.7	46.8	106.2	59.3	100.0	53.1	54.0
	kVA	5.6	7.1	11.2	11.3	11.3	22.5	22.5	11.2	12.7	7.1	24.0	12.7	11.2
	Line Fuse	80	100	150	150	70	125	125	70	125	60	125	70	60
85-Y045	Load Amps	62.5	79.1	125.0	126.1	63.0	125.0	125.0	62.5	141.6	79.1	133.3	70.8	72.1
	kVA	7.5	9.5	15.0	15.1	15.1	30.0	30.0	15.0	17.0	9.5	32.0	17.0	15.0
	Line Fuse	110	125	200	200	90	175	175	100	175	80	150	90	80
85-Y050	Load Amps	93.7	118.7	187.5	189.2	94.6	187.5	187.5	93.7	212.5	118.7	200.0	106.2	108.1
	kVA	11.2	14.2	22.5	22.7	22.7	45.0	45.0	22.5	25.5	14.2	48.0	25.5	22.5
	Line Fuse	175	200	300	300	150	300	300	150	250	125	225	150	125
85-Y055	Load Amps	156.2	197.9	312.5	315.4	157.7	312.5	312.5	156.2	354.1	197.9	333.3	177.0	180.2
	kVA	18.7	23.7	37.5	37.8	37.8	75.0	75.0	37.5	42.5	23.7	80.0	42.5	37.5
	Line Fuse	300	350	500	450	250	450	450	250	400	200	400	250	200
Qty. Required		1	1	1	1	1	1	1	1	1	1	1	1	1
Connection Dia.		SP - 8	SP -12	SP - 7	SP -11	SP - 10	SP - 5	SP - 9	SP - 6	SP - 3	SP - 4	SP - 1	SP - 2	SP -13
Page		59	60	59	60	60	59	60	59	59	59	59	59	60

Connection diagrams may be found on Pgs. 59 - 60.

Connections found on this Page require ordering  
**1 Buck - Boost Transformer**

The appropriate size 35 or 80 Series Transformer may be substituted for the 85 Series where desired.



# Single Phase Buck - Boost Sizing Tables

## SINGLE PHASE BUCK - BOOST TABLE, TYPE LM

Type LM		Single Phase / Single Unit - Type LM													
Catalog Number	Load Line	Boost - Increase Voltage								Buck - Decrease Voltage					
		240	240	240	240	480	480	480	480	230	230	240	240	480	480
35-LM010	Line	192	200	216	218	432	437	456	457	253	277	264	288	504	528
	Load Amps	2.0	2.0	4.1	4.1	2.0	2.1	4.1	4.1	4.5	2.4	4.5	2.5	4.3	2.2
	kVA	0.50	0.50	1.00	1.00	1.00	1.01	2.00	1.98	1.05	0.56	1.10	0.60	2.10	1.10
35-LM015	Line Fuse	5	5	8	7	5	5	7	7	7	5	7	7	5	7
	Load Amps	3.1	3.1	6.2	6.2	3.1	3.1	6.2	6.2	6.8	3.6	6.8	3.7	6.5	3.4
	kVA	0.75	0.75	1.50	1.50	1.50	1.52	3.00	2.98	1.58	0.84	1.65	0.90	3.15	1.65
85-LM020	Line Fuse	7	7	10	12	6	6	10	10	10	5	10	5	10	5
	Load Amps	5.2	5.2	10.4	10.4	5.2	5.2	10.4	10.3	11.4	6.1	11.4	6.2	10.9	5.7
	kVA	1.25	1.25	2.50	2.50	2.50	2.54	5.00	4.96	2.63	1.41	2.75	1.50	5.25	2.75
85-LM025	Line Fuse	10	10	15	15	10	10	15	15	15	9	15	9	15	9
	Load Amps	10.4	10.4	20.8	20.8	10.4	10.5	20.8	20.6	22.9	12.2	22.9	12.5	21.8	11.4
	kVA	2.50	2.50	5.00	5.00	5.00	5.08	10.00	9.93	5.27	2.82	5.50	3.00	10.50	5.50
85-LM030	Line Fuse	20	20	30	30	15	15	30	30	30	15	30	15	30	15
	Load Amps	15.6	15.6	31.2	31.2	15.6	15.8	31.2	31.0	34.3	18.4	34.3	18.7	32.8	17.1
	kVA	3.75	3.75	7.50	7.50	7.50	7.62	15.00	14.90	7.90	4.23	8.25	4.50	15.75	8.25
85-LM035	Line Fuse	25	25	45	45	25	25	45	45	40	20	20	20	40	20
	Load Amps	20.8	20.8	41.6	41.6	20.8	21.1	41.6	41.3	45.8	24.5	45.8	25.0	43.7	22.9
	kVA	5.00	5.00	10.00	10.00	10.00	10.16	20.00	19.87	10.54	5.64	11.00	6.00	21.00	11.00
85-LM040	Line Fuse	35	35	60	60	30	30	60	60	60	30	60	30	60	30
	Load Amps	31.2	31.2	62.5	62.5	31.2	31.7	62.5	62.0	68.7	36.8	68.7	37.5	65.6	34.3
	kVA	7.50	7.50	15.00	15.00	15.00	15.24	30.00	29.80	15.81	8.47	16.50	9.00	31.50	16.50
85-LM045	Line Fuse	50	50	90	90	45	45	90	90	80	40	80	40	80	40
	Load Amps	41.6	41.6	83.3	83.3	41.6	42.3	83.3	82.7	91.6	49.1	91.6	50.0	87.5	45.8
	kVA	10.0	10.0	20.0	20.0	20.0	20.3	40.0	39.7	21.0	11.2	22.0	12.0	42.0	22.0
85-LM050	Line Fuse	70	70	125	125	60	60	110	110	110	60	110	60	110	60
	Load Amps	62.5	62.5	125.0	124.9	62.5	63.5	125.0	124.1	137.5	73.6	137.5	75.0	131.2	68.7
	kVA	15.0	15.0	30.0	30.0	30.0	30.4	60.0	59.6	31.6	16.9	33.0	18.0	63.0	33.0
85-LM055	Line Fuse	100	100	175	175	90	90	175	175	175	80	175	80	175	80
	Load Amps	104.1	104.1	208.3	208.3	104.1	105.8	208.3	206.9	229.1	122.7	229.1	125.0	218.7	114.5
	kVA	25.0	25.0	50.0	50.0	50.0	50.8	100.0	99.3	52.7	28.2	55.0	30.0	105.0	55.0
Qty. Required	Line Fuse	175	175	300	300	150	150	300	300	300	150	300	150	300	150
	Connection Dia. Page	1 SP - 8 59	1 SP -12 60	1 SP - 7 59	1 SP -11 60	1 SP - 6 59	1 SP -10 60	1 SP - 5 59	1 SP - 9 60	1 SP - 3 59	1 SP - 4 59	1 SP - 3 59	1 SP - 4 59	1 SP - 1 59	1 SP - 2 59

DONGAN ELECTRIC MANUFACTURING CO. • 2987 FRANKLIN • DETROIT, MI 48207  
 800.428.2626 • 313.567.8500 • FAX 313.567.8828 • www.dongan.com

$$\text{Single Phase kVA} = \frac{\text{Load Voltage} \times \text{Load Amps}}{1000} \qquad \text{kVA} = \frac{\text{Volt Amperes}}{1000}$$

$$\text{Three Phase kVA} = \frac{\text{Load Voltage} \times \text{Load Amps} \times 1.73}{1000} \qquad \text{VA} = \text{kVA} \times 1000$$

Connection diagrams may be found on Pgs. 59 - 60.  
**Connections found on this Page require ordering 1 Buck - Boost Transformer**  
 The appropriate size 35 or 80 Series Transformer may be substituted for the 85 Series where desired.



# Three Phase Buck - Boost Sizing Tables

DONGAN ELECTRIC MANUFACTURING CO. • 2987 FRANKLIN • DETROIT, MI 48207  
 800.428.2626 • 313.567.8500 • FAX 313.567.8828 • www.dongan.com

## THREE PHASE BUCK - BOOST TABLE, TYPE M

Type M		Three Phase / Two or Three Units - Type M															
Catalog Number	Load Line	Boost - Increase Voltage										Buck - Decrease Voltage					
		208	208	208	230	240	240	416	416	416	416	208	208	240	240	416	416
		166	173	187	208	216	228	374	377	395	397	230	249	252	264	437	457
35-M005	Load Amps	1.6	2.0	3.6	4.1	1.8	3.9	1.8	2.0	3.9	4.1	4.5	2.4	4.3	2.2	4.3	2.2
	kVA	0.60	0.75	1.30	1.64	0.77	1.64	1.34	1.50	2.85	3.95	1.64	0.90	1.82	0.95	3.12	1.65
	Line Fuse	5	5	7	8	5	7	5	5	7	7	7	5	7	5	7	5
35-M010	Load Amps	3.3	4.1	7.2	8.2	3.7	7.8	3.7	4.1	7.9	8.3	9.1	4.9	8.7	4.5	8.6	4.5
	kVA	1.20	1.49	2.60	3.29	1.55	3.28	2.69	3.00	5.70	5.99	3.29	1.80	3.64	1.90	6.24	3.30
	Line Fuse	7	8	15	12	7	15	7	7.5	15	15	15	7	15		15	7
35-M015	Load Amps	4.9	6.2	10.8	12.4	5.5	11.8	5.6	6.2	11.8	12.4	13.7	7.4	13.1	6.8	12.9	6.8
	kVA	1.80	2.24	3.90	4.94	2.32	4.92	4.04	4.50	8.55	8.99	4.94	2.70	5.46	2.86	9.36	4.95
	Line Fuse	10	12	20	20	10	20	12	10	20	20	20	10	20	10	20	10
85-M020	Load Amps	8.3	10.4	18.0	20.6	9.3	19.7	9.3	10.4	19.7	20.8	22.8	12.4	21.9	11.4	21.6	11.4
	kVA	3.00	3.74	6.50	8.23	3.87	8.20	6.74	7.50	14.26	14.99	8.23	4.50	9.10	4.76	15.60	8.25
	Line Fuse	15	20	30	30	15	30	15	15	30	30	30	15	30	15	30	15
85-M025	Load Amps	16.6	20.8	36.0	41.3	18.6	39.4	18.7	20.8	39.5	41.6	45.7	24.9	43.8	22.9	43.3	22.9
	kVA	6.00	7.49	13.00	16.46	7.75	16.40	13.49	15.00	28.52	29.98	16.46	9.00	18.20	9.53	31.21	16.50
	Line Fuse	30	35	60	60	30	60	30	30	60	60	60	30	60	30	60	30
85-M030	Load Amps	24.9	31.2	54.1	62.0	27.9	59.1	28.0	31.2	59.3	62.42	68.5	37.4	65.7	34.4	64.9	34.3
	kVA	9.00	11.24	19.50	24.69	11.62	24.60	20.23	22.50	42.78	44.97	24.69	13.50	27.31	14.30	46.82	24.75
	Line Fuse	45	50	80	90	45	80	45	45	80	90	80	45	80	45	80	45
85-M035	Load Amps	33.3	41.6	72.1	82.6	37.2	78.9	37.4	41.6	79.1	83.2	91.4	49.9	87.6	45.8	86.6	45.8
	kVA	12.00	14.99	26.00	32.93	15.50	32.80	26.98	30.00	57.05	59.97	32.93	18.00	36.41	19.07	62.49	33.00
	Line Fuse	60	70	110	125	60	110	60	60	110	110	110	60	110	60	110	60
85-M040	Load Amps	49.9	62.4	108.2	124.0	55.9	118.3	56.17	62.45	118.7	124.8	137.1	74.9	131.4	68.8	129.9	68.7
	kVA	18.00	22.49	39.00	49.39	23.25	49.20	40.47	45.00	85.57	89.95	49.39	27.00	54.62	28.61	93.64	49.50
	Line Fuse	80	100	175	175	80	175	80	90	175	175	175	80	175	80	175	80
85-M045	Load Amps	66.6	83.2	144.3	165.3	74.5	157.8	74.8	83.2	158.3	166.4	182.8	99.9	175.2	91.7	173.2	91.6
	kVA	24.0	29.9	52.0	65.8	31.1	65.6	53.9	60.0	114.1	119.9	65.8	36.0	72.8	38.1	124.8	66.0
	Line Fuse	110	150	225	250	110	250	110	125	250	250	225	110	225	110	225	110
85-M050	Load Amps	99.9	124.8	216.5	248.0	111.8	236.7	112.3	124.9	237.5	249.6	274.2	149.9	262.8	137.6	259.9	137.4
	kVA	36.0	44.9	78.8	98.7	46.5	98.4	80.9	90.00	171.1	179.9	98.7	54.0	109.2	57.2	187.2	99.0
	Line Fuse	175	200	350	400	175	250	175	175	350	350	350	175	350	175	350	175
85-M055	Load Amps	166.6	208.1	360.8	413.3	186.4	394.5	187.2	208.1	395.9	416.1	457.0	249.8	438.0	229.4	433.2	229.0
	kVA	60.0	74.9	130.0	164.6	77.5	164.0	134.9	150.0	285.2	299.8	164.6	90.0	182.0	95.3	312.1	165.0
	Line Fuse	300	350	600	600	300	600	200	300	600	600	600	300	600	300	600	300
Qty. Required		3	3	3	3	2	2	3	3	3	3	3	3	2	2	3	3
Connection Dia.		TP-18	TP-22	TP-17	TP-21	TP-5	TP-6	TP-20	TP-24	TP-19	TP-23	TP-13	TP-14	TP-10	TP-9	TP-15	TP-16
Page		62	63	62	63	61	61	63	63	63	63	62	62	62	61	62	62

$$\text{Single Phase kVA} = \frac{\text{Load Voltage} \times \text{Load Amps}}{1000} \quad \text{kVA} = \frac{\text{Volt Amperes}}{1000}$$

$$\text{Three Phase kVA} = \frac{\text{Load Voltage} \times \text{Load Amps} \times 1.73}{1000} \quad \text{VA} = \text{kVA} \times 1000$$

Connection diagrams may be found on Pgs. 61 - 63.

**Connections found on this Page require ordering 2 or 3 Buck - Boost Transformers**

The appropriate size 35 or 80 Series Transformer may be substituted for the 85 Series where desired.



# Three Phase Buck - Boost Sizing Tables

## THREE PHASE BUCK - BOOST TABLE, TYPE Y

Type Y		Three Phase / Two and Three Units - Type Y										Buck - Decrease Voltage					
Catalog Number	Load Line	Boost - Increase Voltage										Buck - Decrease Voltage					
		208	208	208	235	240	240	240	416	416	471	208	208	208	240	240	416
		152	164	180	208	208	212	224	360	388	416	263	235	240	256	272	390
35-Y005	Load Amps	1.5	1.5	2.6	3.1	1.3	1.5	2.9	1.3	2.9	1.5	1.9	3.5	1.5	3.3	1.77	3.1
	kVA	0.55	0.55	0.96	1.27	0.56	0.64	1.21	0.96	2.09	1.25	0.69	1.27	0.56	1.38	.73	2.25
	Line Fuse	5	5	5	5	5	5	5	5	5	5	5	5	4	5	5	5.6
35-Y010	Load Amps	3.0	3.1	5.3	6.2	2.7	3.0	5.8	2.6	5.8	3.0	3.8	7.0	3.1	6.6	3.5	6.2
	kVA	1.11	1.11	1.93	2.54	1.12	1.28	2.42	1.93	4.19	2.50	1.39	2.54	1.12	2.77	1.47	4.50
	Line Fuse	5	7	10	12	5	5	10	5	12	6	5	10	5	10	5	7
35-Y015	Load Amps	4.6	4.6	8.0	9.3	4.0	4.6	8.7	4.0	8.7	4.6	5.8	10.6	4.6	10.0	5.3	9.3
	kVA	1.67	1.67	2.89	3.81	1.68	1.92	3.63	2.89	6.28	3.75	2.09	3.81	1.68	4.16	2.21	6.75
	Line Fuse	8	10	12	15	8	9	15	7.5	15	9	8	15	7	15	9	15
85-Y020	Load Amps	7.7	7.7	13.4	15.6	6.7	7.7	14.5	6.7	14.5	7.6	9.7	17.6	7.8	16.6	8.8	15.6
	kVA	2.78	2.79	4.83	6.36	2.81	3.21	6.05	4.83	10.47	6.26	3.49	6.36	2.81	6.93	3.68	11.25
	Line Fuse	12	15	25	30	15	15	25	15	25	15	15	25	10	25	15	25
85-Y025	Load Amps	15.4	15.5	26.8	31.2	13.5	15.4	29.1	13.4	29.0	15.3	19.4	35.3	15.6	33.3	17.7	31.2
	kVA	5.57	5.58	9.66	12.72	5.62	6.42	12.10	9.66	20.94	12.52	6.99	12.72	5.62	13.87	7.37	22.51
	Line Fuse	25	25	45	45	25	25	45	25	45	25	25	45	25	45	25	45
85-Y030	Load Amps	23.1	23.2	40.2	46.9	20.2	23.1	43.6	20.1	43.6	23.0	29.1	53.0	23.4	50.0	26.5	46.8
	kVA	8.35	8.38	14.49	19.09	8.43	9.64	18.15	14.49	31.42	18.78	10.49	19.09	8.43	20.80	11.05	33.76
	Line Fuse	35	45	60	70	35	35	60	35	60	35	30	60	30	60	30	70
85-Y035	Load Amps	30.9	31.0	53.6	62.5	27.0	30.9	58.2	26.8	58.1	30.7	38.8	70.6	31.2	66.7	35.4	62.4
	kVA	11.14	11.17	19.32	25.45	11.25	12.85	24.21	19.32	41.89	25.04	13.98	25.45	11.25	27.74	14.73	45.02
	Line Fuse	45	50	80	90	45	45	80	45	80	45	45	80	40	80	40	90
85-Y040	Load Amps	46.3	46.5	80.4	93.8	40.5	46.3	87.3	40.2	87.2	46.0	58.2	106.0	46.8	100.1	53.1	93.7
	kVA	16.7	16.7	28.9	38.1	16.8	19.2	36.3	28.9	62.8	37.5	20.9	38.1	16.8	41.6	22.1	67.5
	Line Fuse	60	80	125	150	60	70	125	60	125	70	60	125	60	125	70	125
85-Y045	Load Amps	61.8	62.0	107.2	125.0	54.1	61.8	116.4	53.6	116.2	61.4	77.6	141.3	62.4	133.4	70.9	124.9
	kVA	22.2	22.3	38.6	50.9	22.5	25.7	48.4	38.6	83.7	50.0	27.9	50.9	22.5	55.4	29.4	90.0
	Line Fuse	80	100	175	200	80	90	175	80	175	125	80	175	70	175	80	175
85-Y050	Load Amps	92.7	93.0	160.9	187.6	81.1	92.7	174.7	80.4	174.4	92.1	116.4	212.0	93.6	200.2	106.3	187.4
	kVA	33.4	33.5	57.9	76.3	33.7	38.5	72.6	57.9	125.6	75.1	41.9	76.3	33.7	83.2	44.2	135.0
	Line Fuse	125	175	250	300	125	150	250	150	250	150	125	250	125	250	150	250
85-Y055	Load Amps	154.6	155.1	268.1	312.7	135.3	154.6	291.2	134.0	290.7	153.5	194.1	353.3	156.1	333.7	177.2	312.4
	kVA	55.7	55.8	96.6	127.2	56.2	64.2	121.0	96.6	209.4	125.2	69.9	127.2	56.2	138.7	73.6	225.1
	Line Fuse	200	250	400	450	200	225	400	200	400	250	250	400	175	400	200	450
Qty. Required		3	3	3	3	2	2	2	3	3	3	3	3	2	2	2	3
Connection Dia.		TP-18	TP-22	TP-17	TP-21	TP-5	TP-1	TP-6	TP-20	TP-19	TP-24	TP-14	TP-13	TP-2	TP-10	TP-9	TP-23
Page		62	63	62	63	61	61	61	63	63	63	62	62	61	62	61	63

$$\text{Single Phase kVA} = \frac{\text{Load Voltage} \times \text{Load Amps}}{1000}$$

$$\text{kVA} = \frac{\text{Volt Amperes}}{1000}$$

$$\text{Three Phase kVA} = \frac{\text{Load Voltage} \times \text{Load Amps} \times 1.73}{1000}$$

$$\text{VA} = \text{kVA} \times 1000$$

Connection diagrams may be found on Pgs. 61 - 63.

Connections found on this Page require ordering 2 or 3 Buck - Boost Transformers

The appropriate size 35 or 80 Series Transformer may be substituted for the 85 Series where desired.

DONGAN ELECTRIC MANUFACTURING CO. • 2987 FRANKLIN • DETROIT, MI 48207  
 800.428.2626 • 313.567.8500 • FAX 313.567.8828 • www.dongan.com





# Three Phase Buck - Boost Sizing Tables

DONGAN ELECTRIC MANUFACTURING CO. • 2987 FRANKLIN • DETROIT, MI 48207  
 800.428.2626 • 313.567.8500 • FAX 313.567.8828 • www.dongan.com

## THREE PHASE BUCK - BOOST TABLE, TYPE LM

Type LM		Three Phase / Two or Three Units - Type LM																	
Catalog Number	Load Line	Boost - Increase Voltage									Buck - Decrease Voltage								
		240	240	240	416	416	440	480	480	480	200	216	230	230	240	240	416	480	480
35-LM010	Load Amps	1.6	2.0	3.7	1.6	2.0	4.1	2.1	1.8	3.9	2.4	4.1	4.5	2.4	4.5	2.5	2.5	4.3	2.2
	kVA	0.68	0.86	1.54	1.20	1.50	3.13	1.80	1.54	3.28	0.86	1.54	1.80	0.98	1.90	1.04	1.80	3.64	1.90
	Line Fuse	5	5	7	5	5	7	5	5	7	5	6	7	5	7	5	5	7	5
35-LM015	Load Amps	2.4	3.1	5.5	2.5	3.1	6.1	3.2	2.7	5.9	3.7	6.1	6.7	3.7	6.8	3.7	3.7	6.5	3.4
	kVA	1.02	1.29	2.31	1.80	2.26	4.70	2.70	2.31	4.92	1.29	2.31	2.70	1.47	2.86	1.56	2.70	5.46	2.86
	Line Fuse	5	6	10	5	6	10	6	5	10	5	9	10	5	10	5	5	10	5
85-LM020	Load Amps	4.0	5.1	9.2	4.1	5.2	10.2	5.4	4.6	9.8	6.2	10.2	11.3	6.1	11.4	6.2	6.2	10.9	5.7
	kVA	1.70	2.15	3.85	3.00	3.76	7.83	4.50	3.85	8.20	2.15	3.85	4.51	2.46	4.76	2.60	4.50	9.10	4.76
	Line Fuse	8	10	15	9	10	15	10	8	15	8	15	15	8	15	9	9	15	9
85-LM025	Load Amps	8.1	10.3	18.5	8.3	10.4	20.5	10.8	9.2	19.7	12.4	20.8	22.6	12.3	12.9	12.5	12.5	21.9	11.4
	kVA	3.40	4.30	7.70	6.01	7.53	15.67	9.00	7.70	16.40	4.30	7.70	9.02	4.92	9.53	5.20	9.01	18.20	9.53
	Line Fuse	15	20	30	15	20	30	20	15	30	15	25	30	15	30	15	15	30	15
85-LM030	Load Amps	12.2	15.5	27.7	12.5	15.6	30.8	16.2	13.8	29.5	18.6	30.8	33.9	18.5	34.4	18.7	18.7	32.8	17.2
	kVA	5.10	6.46	11.55	9.02	11.29	23.51	13.50	11.55	24.60	6.46	11.55	13.5	7.38	14.30	7.80	13.52	27.31	14.30
	Line Fuse	25	25	45	25	25	45	25	25	45	25	45	45	25	45	25	25	45	25
85-LM035	Load Amps	16.3	20.7	37.0	16.7	20.9	41.1	21.6	18.5	39.4	24.8	41.1	45.2	24.7	45.8	25.0	25.0	43.8	22.9
	kVA	6.80	8.61	15.40	12.03	15.06	31.35	18.00	15.40	32.80	8.61	15.40	18.04	9.84	19.07	10.40	18.03	36.41	19.07
	Line Fuse	30	35	60	30	35	60	35	30	60	30	50	60	30	60	30	30	60	30
85-LM040	Load Amps	24.5	31.0	55.5	25.0	31.3	61.7	32.4	27.7	59.1	37.3	61.7	67.9	37.0	68.8	37.5	37.5	65.7	34.4
	kVA	10.2	12.9	23.1	18.0	22.5	47.0	27.0	23.1	49.2	12.9	23.1	27.0	14.7	28.6	15.6	27.0	54.6	28.6
	Line Fuse	45	50	80	45	50	90	50	45	80	45	80	80	45	80	45	45	80	45
85-LM045	Load Amps	32.7	41.4	74.0	33.4	41.8	82.2	43.3	37.0	78.9	49.7	82.3	90.5	49.4	91.7	50.0	50.0	87.6	45.8
	kVA	13.6	17.2	30.8	24.0	30.1	62.7	36.0	30.8	65.6	17.2	30.8	36.0	19.6	38.1	20.8	36.0	72.8	38.1
	Line Fuse	60	60	110	60	70	125	70	60	110	60	100	110	60	110	60	60	110	60
85-LM050	Load Amps	49.0	62.1	111.1	50.1	62.7	123.4	64.9	55.5	118.3	74.6	123.4	135.8	74.1	137.6	75.0	75.0	131.4	68.8
	kVA	20.4	25.8	46.2	36.1	45.1	94.0	54.0	46.2	98.4	25.8	46.2	54.1	29.5	57.2	31.2	54.1	109.2	57.2
	Line Fuse	80	100	175	80	100	175	100	80	175	80	150	175	80	175	80	80	175	80
85-LM055	Load Amps	81.7	103.6	185.2	83.5	104.5	205.6	108.2	92.6	197.2	124.3	205.8	226.4	123.5	229.4	125.1	125.1	219.0	114.7
	kVA	34.0	43.0	77.0	60.1	75.3	156.7	90.0	77.6	164.0	43.0	77.0	90.2	49.2	95.3	52.0	90.1	182.0	95.3
	Line Fuse	150	175	300	150	175	300	175	150	300	150	250	300	150	300	150	150	300	150
Qty. Required		2	2	2	3	3	3	3	2	2	2	2	2	2	2	2	3	2	2
Connection Dia.		TP-7	TP-3	TP-4	TP-18	TP-22	TP-21	TP-22	TP-5	TP-6	TP-11	TP-8	TP-12	TP-11	TP-12	TP-11	TP-14	TP-10	TP-9
Page		61	61	61	62	63	63	63	61	61	62	61	62	62	62	62	62	62	61

$$\text{Single Phase kVA} = \frac{\text{Load Voltage} \times \text{Load Amps}}{1000}$$

$$\text{kVA} = \frac{\text{Volt Amperes}}{1000}$$

$$\text{Three Phase kVA} = \frac{\text{Load Voltage} \times \text{Load Amps} \times 1.73}{1000}$$

$$\text{VA} = \text{kVA} \times 1000$$

Connection diagrams may be found on Pgs. 61 - 63.

**Connections found on this Page require ordering 2 or 3 Buck - Boost Transformers**

The appropriate size 35 or 80 Series Transformer may be substituted for the 85 Series where desired.

# Buck - Boost Connection Diagrams

## Single Phase Connection Diagrams

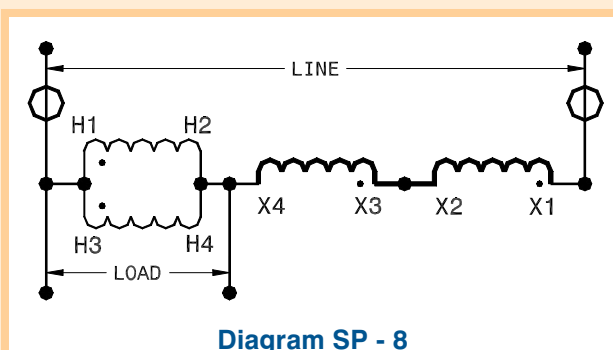
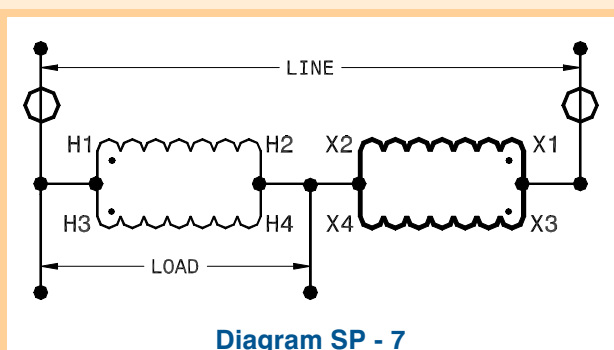
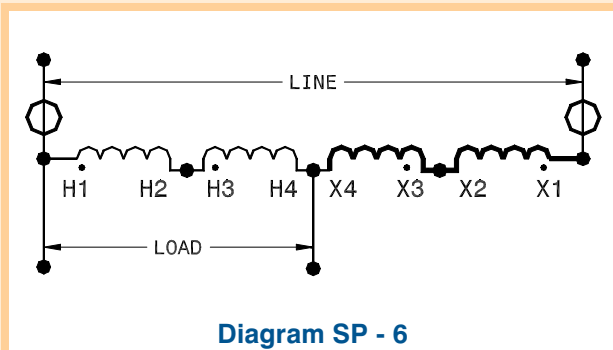
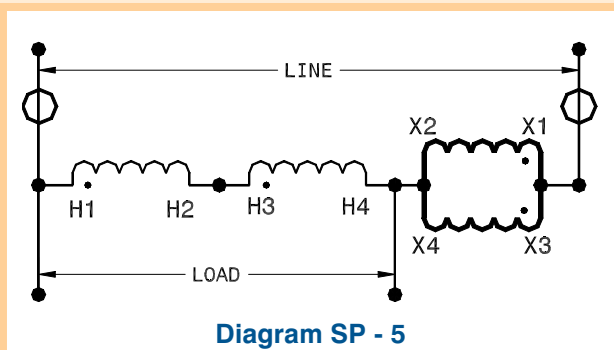
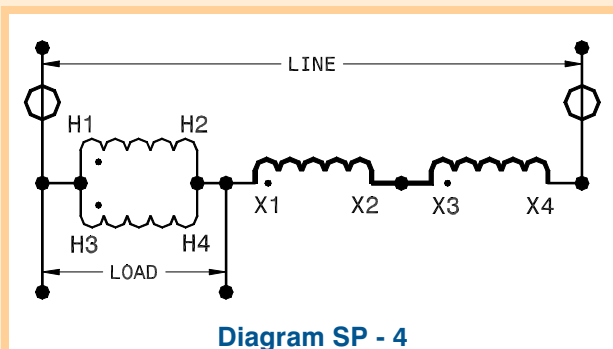
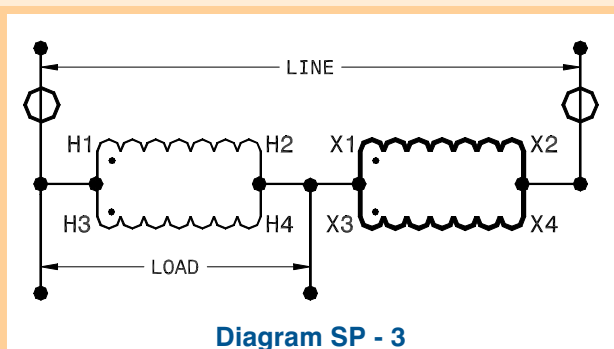
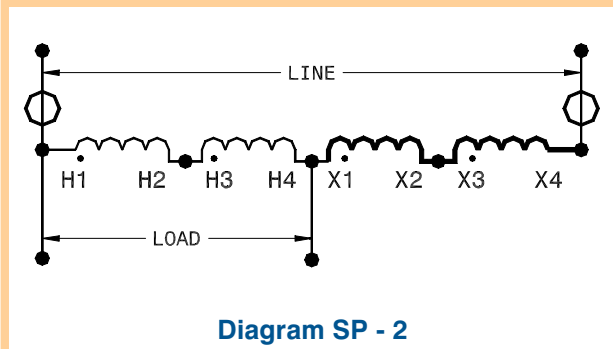
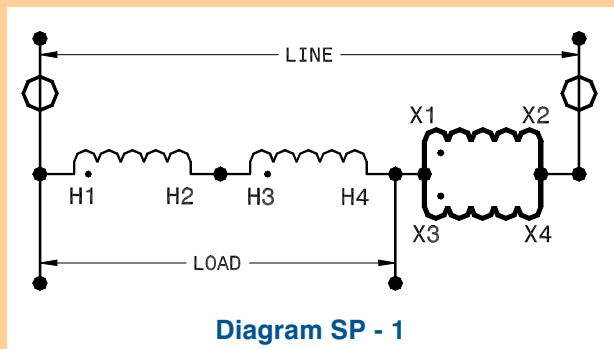

# Buck - Boost Connection Diagrams

DONGAN ELECTRIC MANUFACTURING CO. • 2987 FRANKLIN • DETROIT, MI 48207  
 800.428.2626 • 313.567.8500 • FAX 313.567.8828 • www.dongan.com

## Single Phase Connection Diagrams

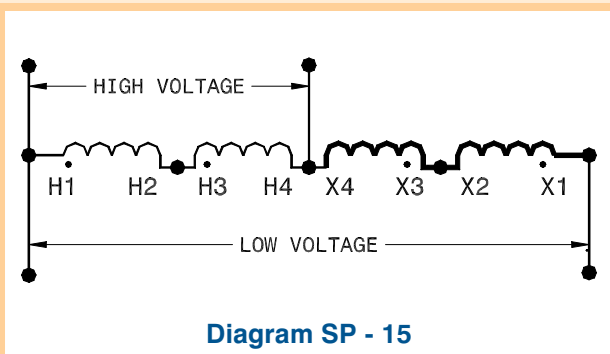
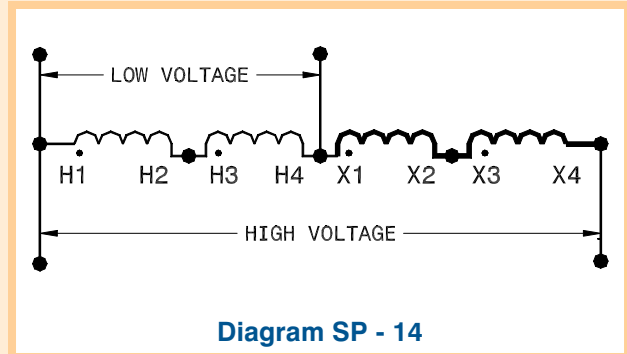
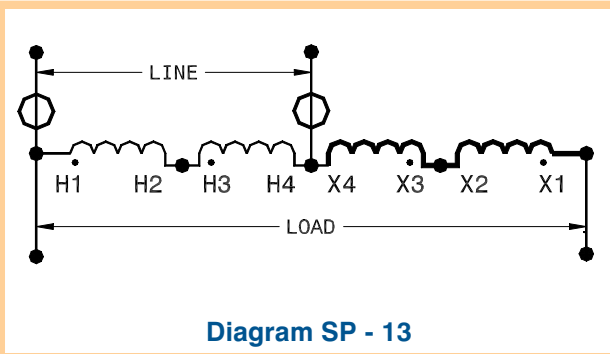
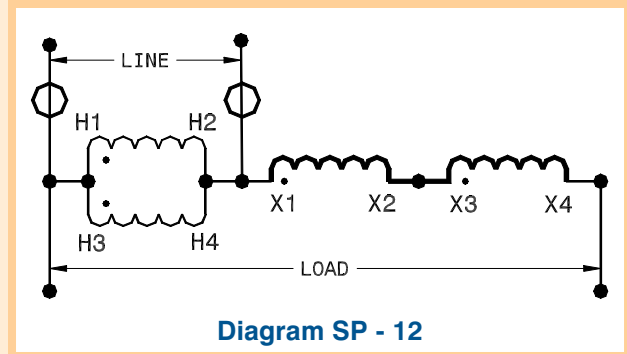
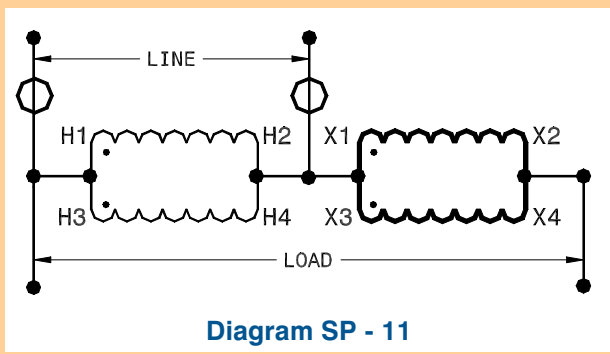
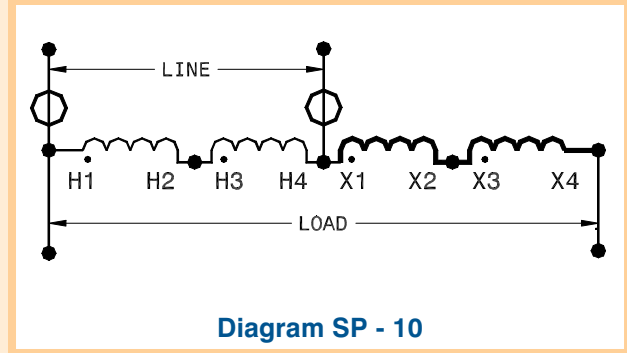
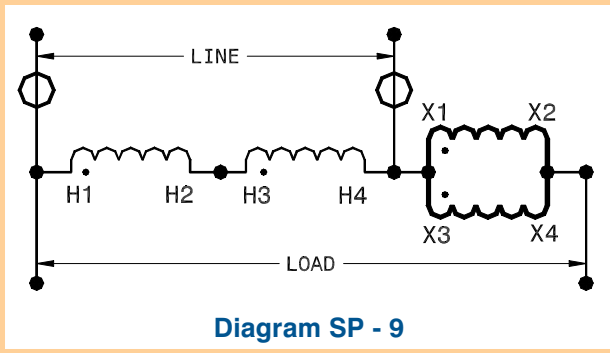

### Symbol Key

**O** - Indicates Overcurrent Protection

**Note:** If present, do not fuse grounded conductor

# Buck - Boost Connection Diagrams

## Three Phase Connection Diagrams

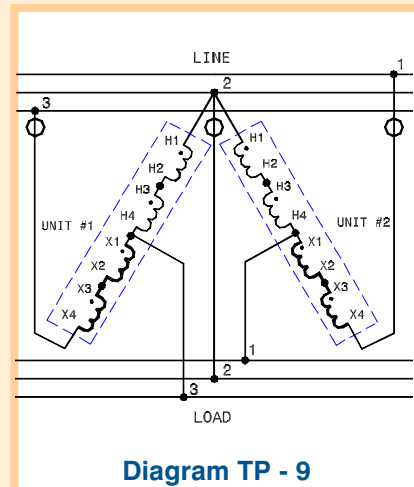
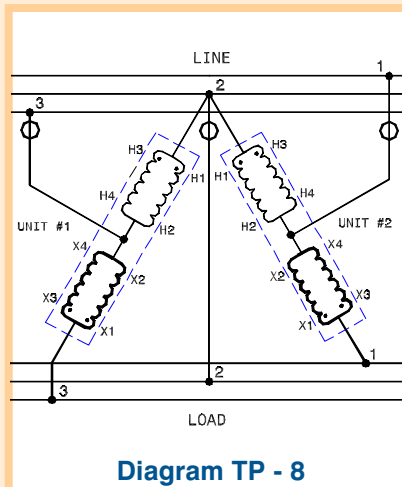
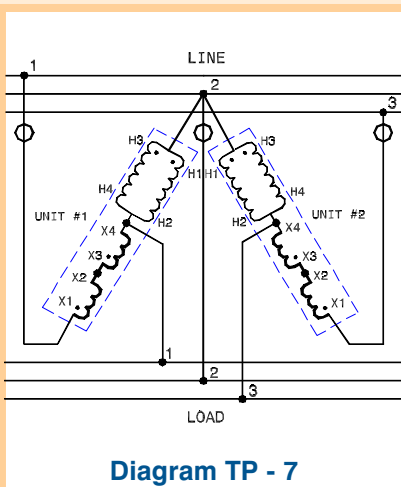
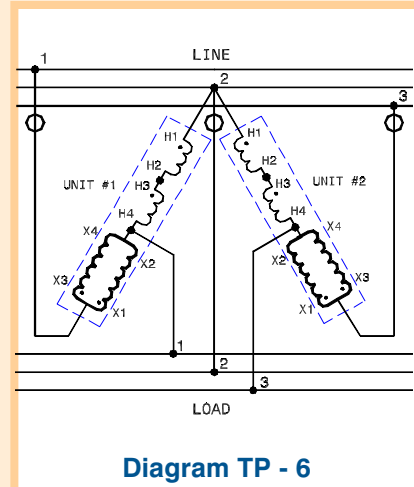
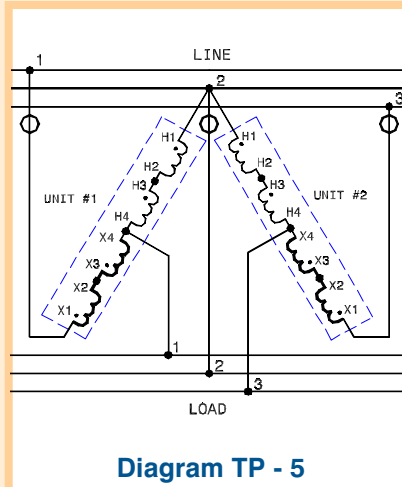
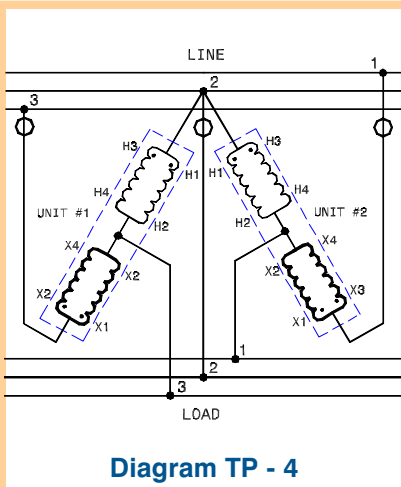
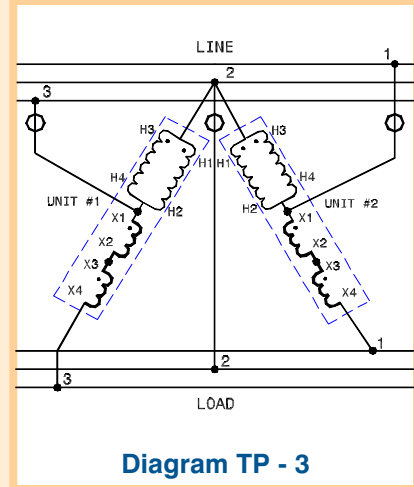
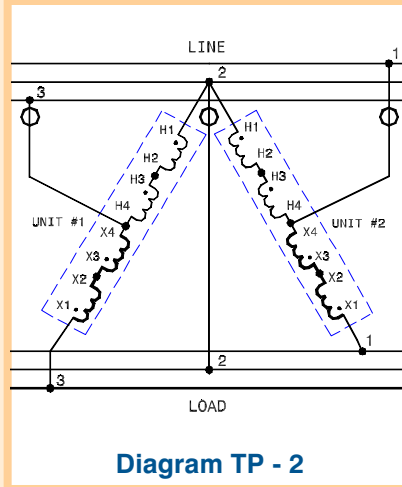
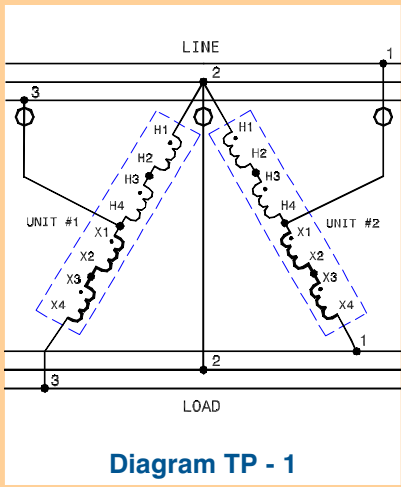

DONGAN ELECTRIC MANUFACTURING CO. • 2987 FRANKLIN • DETROIT, MI 48207  
800.428.2626 • 313.567.8500 • FAX 313.567.8828 • www.dongan.com

## Three Phase Connection Diagrams

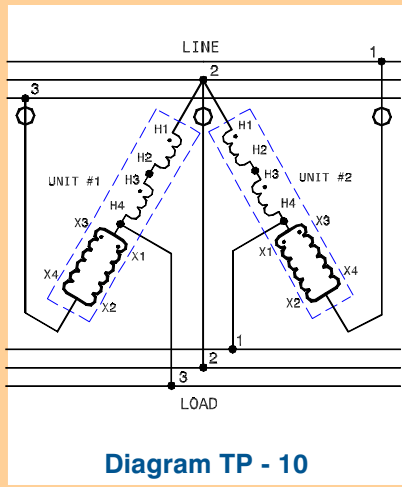

**Diagram TP - 10**

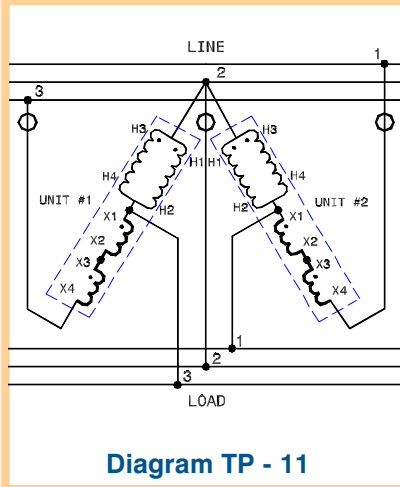

**Diagram TP - 11**

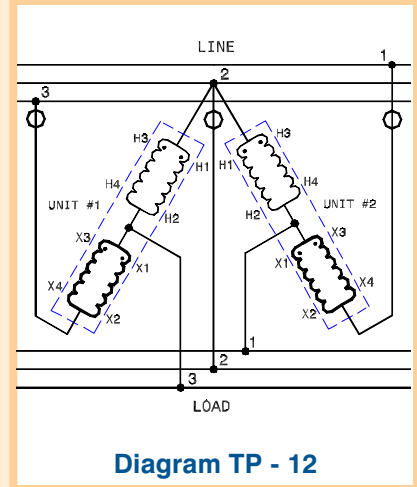

**Diagram TP - 12**

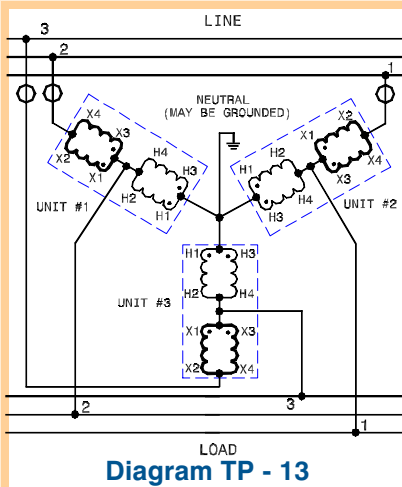

**Diagram TP - 13**

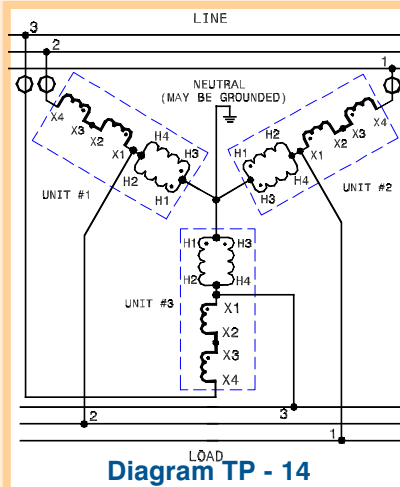

**Diagram TP - 14**

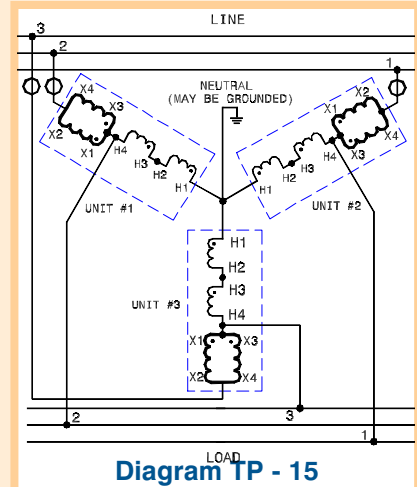

**Diagram TP - 15**

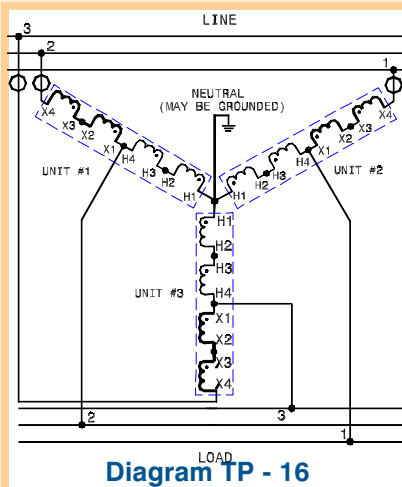

**Diagram TP - 16**

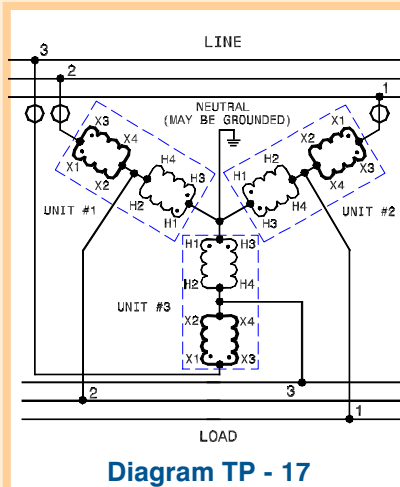

**Diagram TP - 17**

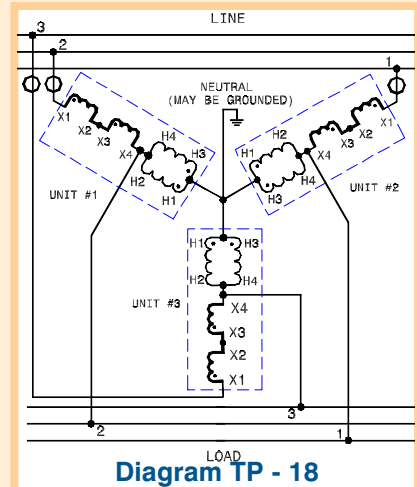
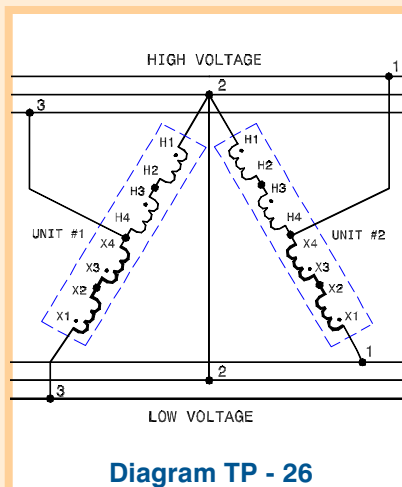
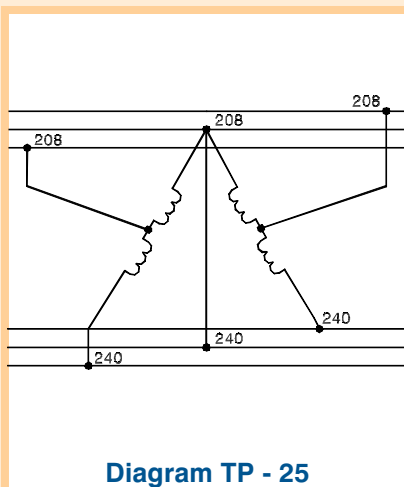
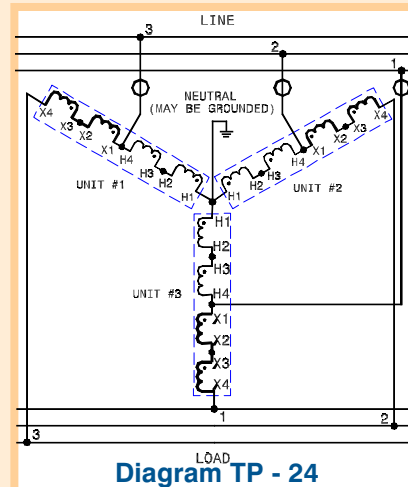
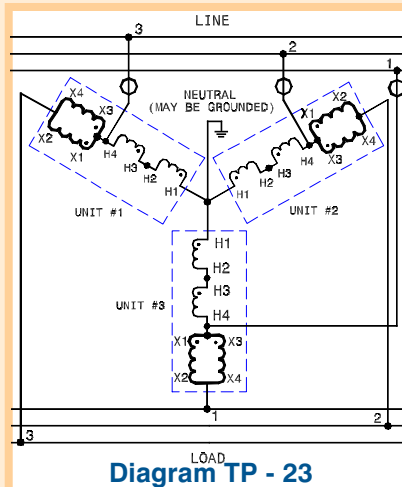
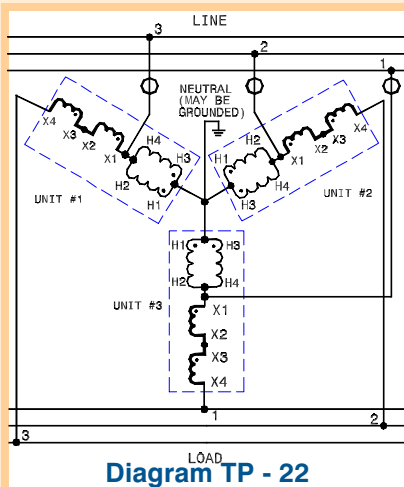
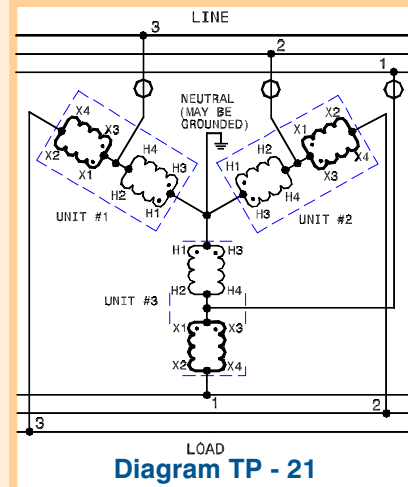
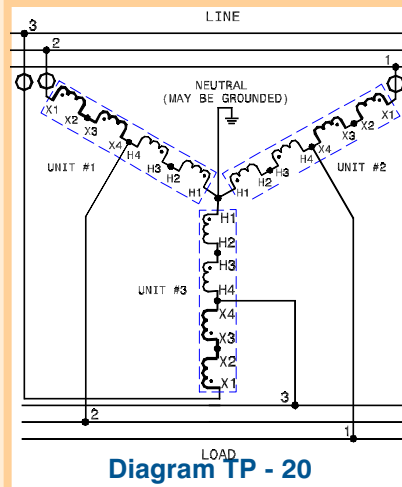
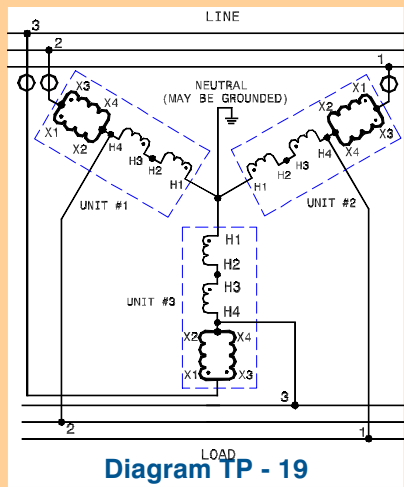

**Diagram TP - 18**



# Buck - Boost Connection Diagrams

## Three Phase Connection Diagrams



**Symbol Key**

**O** - Indicates Overcurrent Protection

**Note:** If present, do not fuse grounded conductor

DONGAN ELECTRIC MANUFACTURING CO. • 2987 FRANKLIN • DETROIT, MI 48207  
 800.428.2626 • 313.567.8500 • FAX 313.567.8828 • www.dongan.com

## PRIMARY VOLTS 120 X 240, SECONDARY VOLTS 12 / 24

General Information				Winding Specifications			Dimensions				
kVA Cap.	Catalog Number	Hz.	Wgt. Lbs	Taps	Maximum Amps		Conn Dia. Pg. 66	Height A	Width B	Depth C	Outline Dwg.
					Pri.	Sec.					
.050	35-M005*	50/60	4	0	.4 / .2	4.1 / 2.0	18	6.37	3.75	3.37	1
.100	35-M010*	50/60	5	0	.8 / .4	8.3 / 4.1	18	6.37	3.75	3.37	1
.150	35-M015*	50/60	7	0	1.2 / .6	12.5 / 6.2	18	7.00	3.87	3.37	2
.250	85-M020	50/60	15	0	2.0 / 1.0	20.8 / 10.4	18	12.00	4.87	5.25	3
.500	85-M025	50/60	19	0	4.1 / 2.0	41.6 / 20.8	18	12.00	4.87	5.25	3
.750	85-M030	50/60	23	0	6.2 / 3.1	62.5 / 31.2	18	12.00	4.87	5.25	3
1.0	85-M035	60	28	0	8 / 4	83 / 41	18	15.25	5.75	5.87	3
1.5	85-M040	60	39	0	12 / 6	125 / 62	18	15.25	5.75	5.87	3
2.0	85-M045	60	43	0	16 / 8	166 / 83	18	15.25	5.75	5.87	3
3.0	85-M050	60	69	0	25 / 12	250 / 125	18	15.25	8.25	7.87	3
5.0	85-M055	60	89	0	41 / 20	416 / 208	18	15.25	8.25	7.87	3

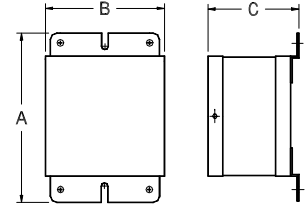

**Outline Drawing 1**  
Wall Mount - Ventilated - NEMA 1

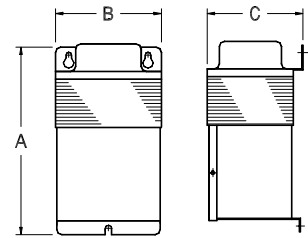

**Outline Drawing 2**  
Wall Mount - Ventilated - NEMA 3R

## PRIMARY VOLTS 120 X 240, SECONDARY VOLTS 16 / 32

General Information				Winding Specifications			Dimensions				
kVA Cap.	Catalog Number	Hz.	Wgt. Lbs	Taps	Maximum Amps		Conn Dia. Pg. 66	Height A	Width B	Depth C	Outline Dwg.
					Pri.	Sec.					
.050	35-Y005*	50/60	4	0	.4 / .2	3.1 / 1.5	19	6.37	3.75	3.37	1
.100	35-Y010*	50/60	5	0	.8 / .4	6.2 / 3.1	19	6.37	3.75	3.37	1
.150	35-Y015*	50/60	7	0	1.2 / .6	9.3 / 4.6	19	7.00	4.00	3.63	2
.250	85-Y020	50/60	15	0	2.0 / 1.0	15.6 / 7.8	19	12.00	4.87	5.25	3
.500	85-Y025	50/60	19	0	4.1 / 2.0	31.2 / 15.6	19	12.00	4.87	5.25	3
.750	85-Y030	50/60	23	0	6.2 / 3.1	46.8 / 23.4	19	12.00	4.87	5.25	3
1.0	85-Y035	60	28	0	8 / 4	62 / 31	19	15.25	5.75	5.87	3
1.5	85-Y040	60	39	0	12 / 6	93 / 46	19	15.25	5.75	5.87	3
2.0	85-Y045	60	43	0	16 / 8	125 / 62	19	15.25	5.75	5.87	3
3.0	85-Y050	60	69	0	25 / 12	187 / 93	19	15.25	8.25	7.87	3
5.0	85-Y055	60	89	0	41 / 20	312 / 156	19	15.25	8.25	7.87	3

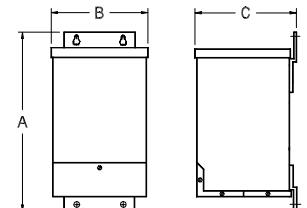

**Outline Drawing 3**  
Wall Mount - Encapsulated - NEMA 3R  
Note: 3 kVA & 5kVA 85 Series are also available in Outline Drawing 4 Configuration

## PRIMARY VOLTS 240 X 480, SECONDARY VOLTS 24 / 48

General Information				Winding Specifications			Dimensions				
kVA Cap.	Catalog Number	Hz.	Wgt. Lbs	Taps	Maximum Amps		Conn Dia. Pg. 66	Height A	Width B	Depth C	Outline Dwg.
					Pri.	Sec.					
.100	35-LM010*	50/60	5	0	.4 / .2	4.1 / 2.0	20	6.37	3.75	3.37	1
.150	35-LM015*	50/60	7	0	.6 / .3	6.2 / 3.1	20	7.00	4.00	3.63	2
.250	85-LM020	50/60	15	0	1.0 / .52	10.4 / 5.2	20	12.00	4.87	5.25	3
.500	85-LM025	50/60	19	0	2.0 / 1.0	20.8 / 10.4	20	12.00	4.87	5.25	3
.750	85-LM030	50/60	23	0	3.1 / 1.6	31.2 / 15.6	20	12.00	4.87	5.25	3
1.0	85-LM035	60	28	0	4 / 2	41 / 20	20	15.25	5.75	5.87	3
1.5	85-LM040	60	39	0	6 / 3	62 / 31	20	15.25	5.75	5.87	3
2.0	85-LM045	60	43	0	8 / 4	83 / 41	20	15.25	5.75	5.87	3
3.0	85-LM050	60	69	0	12 / 6	125 / 62	20	15.25	8.25	7.87	3
5.0	85-LM055	60	89	0	20 / 10	208 / 104	20	15.25	8.25	7.87	3

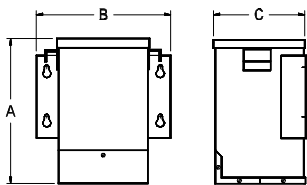

**Outline Drawing 4**  
Wall Mount - Encapsulated - NEMA 3R

Dimensions & weights may change. Consult factory for certified drawings.

kVA capacity, primary amps, and secondary amps are shown with values when used as a low voltage, isolation transformer. Buck - Boost capacities are found on the charts on pages 52 - 58.

\*Series 35 are ventilated units.

# Ventilated Buck - Boost Transformers

## PRIMARY VOLTS 120 X 240, SECONDARY VOLTS 12 / 24

General Information				Winding Specifications			Dimensions				
kVA Cap.	Catalog Number	Hz.	Wgt. Lbs.	Taps	Maximum Amps		Conn Dia. Pg. 66	Height A	Width B	Depth C	Outline Dwg.
					Pri.	Sec.					
.050	35-M005	50/60	5	0	.4 / .2	4.1 / 2.0	18	6.37	3.75	3.37	1
.100	35-M010	50/60	8	0	.8 / .4	8.3 / 4.1	18	6.37	3.75	3.37	1
.150	35-M015	50/60	8	0	1.2 / .6	12.5 / 6.2	18	7.00	4.00	3.63	2
.250	35-M020	50/60	11	0	2.0 / 1.0	20.8 / 10.4	18	7.50	4.63	4.00	2
.500	35-M025	50/60	20	0	4.1 / 2.0	41.6 / 20.8	18	9.28	5.50	4.75	2
.750	35-M030	50/60	28	0	6.2 / 3.1	62.5 / 31.2	18	10.88	5.50	4.75	2
1.0	80-M035	50/60	29	0	8 / 4	83 / 41	18	10.88	5.50	4.75	2
1.5	80-M040	50/60	37	0	12 / 6	125 / 62	18	10.63	6.63	5.88	2
2.0	80-M045	60	42	0	16 / 8	166 / 83	18	11.00	6.63	5.88	2
3.0	80-M050	60	58	0	25 / 12	250 / 125	18	16.38	7.69	6.88	2
5.0	80-M055	60	82	0	41 / 20	416 / 208	18	18.50	7.69	6.88	2

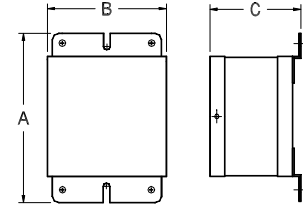

Outline Drawing 1  
Wall Mount - Ventilated - NEMA 1

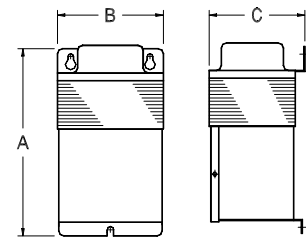

Outline Drawing 2  
Wall Mount - Ventilated - NEMA 3R

## PRIMARY VOLTS 120 X 240, SECONDARY VOLTS 16 / 32

General Information				Winding Specifications			Dimensions				
kVA Cap.	Catalog Number	Hz.	Wgt. Lbs.	Taps	Maximum Amps		Conn Dia. Pg. 66	Height A	Width B	Depth C	Outline Dwg.
					Pri.	Sec.					
.050	35-Y005	50/60	5	0	.4 / .2	3.1 / 1.5	19	6.37	3.75	3.37	1
.100	35-Y010	50/60	8	0	.8 / .4	6.2 / 3.1	19	6.37	3.75	3.37	1
.150	35-Y015	50/60	8	0	1.2 / .6	9.3 / 4.6	19	7.00	4.00	3.63	2
.250	35-Y020	50/60	11	0	2.0 / 1.0	15.6 / 7.8	19	7.50	4.63	4.00	2
.500	35-Y025	50/60	20	0	4.1 / 2.0	31.2 / 15.6	19	9.25	5.50	4.75	2
.750	35-Y030	50/60	28	0	6.2 / 3.1	46.8 / 23.4	19	10.88	5.50	4.75	2
1.0	80-Y035	50/60	29	0	8 / 4	62 / 31	19	10.88	5.50	4.75	2
1.5	80-Y040	50/60	37	0	12 / 6	93 / 46	19	10.63	6.63	5.88	2
2.0	80-Y045	60	42	0	16 / 8	125 / 62	19	11.00	6.63	5.88	2
3.0	80-Y050	60	58	0	25 / 12	187 / 93	19	16.38	7.69	6.88	2
5.0	80-Y055	60	82	0	41 / 20	312 / 156	19	18.50	7.69	6.88	2

## PRIMARY VOLTS 240 X 480, SECONDARY VOLTS 24 / 48

General Information				Windings Specifications			Dimensions				
kVA Cap.	Catalog Number	Hz.	Wgt. Lbs.	Taps	Maximum Amps		Conn Dia. Pg. 66	Height A	Width B	Depth C	Outline Dwg.
					Pri.	Sec.					
.100	35-LM010	50/60	8	0	.4 / .2	4.1 / 2.0	20	6.37	3.75	3.37	1
.150	35-LM015	50/60	8	0	.6 / .3	6.2 / 3.1	20	7.00	4.00	3.63	2
.250	35-LM020	50/60	11	0	1.0 / .52	10.4 / 5.2	20	7.50	4.63	4.00	2
.500	35-LM025	50/60	20	0	2.0 / 1.0	20.8 / 10.4	20	9.25	5.50	4.75	2
.750	35-LM030	50/60	28	0	3.1 / 1.6	31.2 / 15.6	20	10.88	5.50	4.75	2
1.0	80-LM035	50/60	29	0	4 / 2	41 / 20	20	10.88	5.50	4.75	2
1.5	80-LM040	50/60	37	0	6 / 3	62 / 31	20	10.63	6.63	5.88	2
2.0	80-LM045	60	42	0	8 / 4	83 / 41	20	11.00	6.63	5.88	2
3.0	80-LM050	60	58	0	12 / 6	125 / 62	20	16.38	7.69	6.88	2
5.0	80-LM055	60	82	0	20 / 10	208 / 104	20	18.50	7.69	6.88	2

Dimensions & weights may change. Consult factory for certified drawings.

kVA capacity, primary amps, and secondary amps are shown with values when used as a low voltage, isolation transformer. Buck - Boost capacities are found on the charts on pages 52 - 58.

DONGAN ELECTRIC MANUFACTURING CO. • 2987 FRANKLIN • DETROIT, MI 48207  
800.428.2626 • 313.567.8500 • FAX 313.567.8828 • www.dongan.com

## SERIES ODY DIMENSIONS

General Information				Winding Specifications			Dimensions			
kVA Cap.	Catalog Number	Hz.	Wgt. Lbs	Taps	Maximum Amps		Conn Dia.	Height A	Width B	Depth C
					208	240				
2.8	34-280-ODY	60	21	0	7.8	6.7	ODY	10.75	4.50	4.06
5.6	34-560-ODY	60	37	0	15.6	13.5	ODY	12.25	5.31	4.75
8.4	34-840-ODY	60	54	0	23.4	20.2	ODY	15.50	5.31	4.75
11.2	84-1120-ODY	60	55	0	31.2	27.0	ODY	15.50	5.31	4.75
16.9	84-1690-ODY	60	65	0	46.8	40.5	ODY	16.13	7.19	5.81
22.5	84-2250-ODY	60	74	0	62.4	54.1	ODY	17.13	7.19	5.81
33.0	84-3300-ODY	60	127	0	93.6	81.1	ODY	20.50	7.69	6.75
56.0	84-5600-ODY	60	158	0	156.1	135.3	ODY	24.88	7.69	6.75

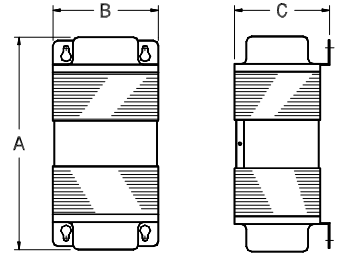

Series ODY  
Wall Mount - Ventiladed - NEMA 3R

## LOW VOLTAGE CONNECTION DIAGRAMS

Dia. 18	Catalog Series 35-MOXX & 80-MOXX 85-MOXX		
Tap Arrangement	No Taps		
% High Voltage	High Voltage 120 X 240	Inter-Connect	Connect High Voltage Lines To
100	120	H1 To H3 H2 To H4	H1H3 & H2H4
100	240	H2 To H3	H1 & H4
% Low Voltage	Low Voltage 12 / 24	Inter-Connect	Connect Low Voltage Lines To
100	12	X1 To X3 X2 To X4	X1X3 & X2X4
100	12 / 24	X2 To X3	X1 & X2X3 & X4
100	24	X2 To X3	X1 & X4

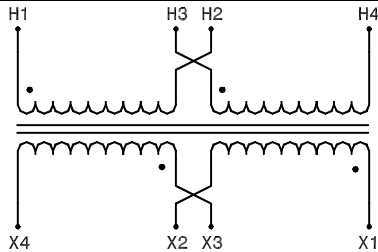

Dia. 19	Catalog Series 35-YOXX & 80-YOXX 85-YOXX		
Tap Arrangement	No Taps		
% High Voltage	High Voltage 120 X 240	Inter-Connect	Connect High Voltage Lines To
100	120	H1 To H3 H2 To H4	H1H3 & H2H4
100	240	H2 To H3	H1 & H4
% Low Voltage	Low Voltage 16 / 32	Inter-Connect	Connect Low Voltage Lines To
100	16	X1 To X3 X2 To X4	X1X3 & X2X4
100	16 / 32	X2 To X3	X1 & X2X3 & X4
100	32	X2 To X3	X1 & X4

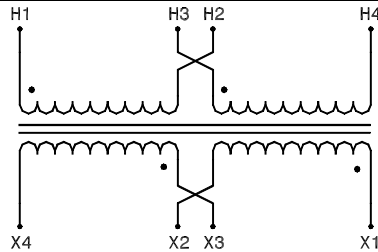

Dia. 20	Catalog Series 35-LMOXX & 80-LMOXX 85-LMOXX		
Tap Arrangement	No Taps		
% High Voltage	High Voltage 240 X 480	Inter-Connect	Connect High Voltage Lines To
100	240	H1 To H3 H2 To H4	H1H3 & H2H4
100	480	H2 To H3	H1 & H4
% Low Voltage	Low Voltage 24 / 48	Inter-Connect	Connect Low Voltage Lines To
100	24	X1 To X3 X2 To X4	X1X3 & X2X4
100	24 / 48	X2 To X3	X1 & X2X3 & X4
100	48	X2 To X3	X1 & X4

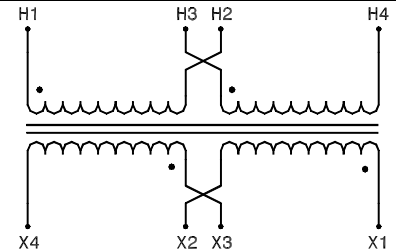

# Industrial Control Transformers

## Contents

Selecting and Sizing an Industrial Control Transformer .....	68
Series 50 Industrial Control Transformers .....	70
Series 50 Industrial Control Transformer Connection Diagrams .....	74
Series 50 Fuse Kits .....	75
Series HC Industrial Control Transformers .....	76
Series HC Fuse Kits .....	79
Series HC Industrial Control Transformer Connection Diagrams .....	80
Control Circuit Overcurrent Protection .....	81
Series ES-10 CE Marked Industrial Control Transformers .....	82
Series ES-10 CE Marked Industrial Control Transformer Connection Diagrams .....	83
Series AP12 - Encapsulated Industrial Control Transformers .....	84
Series FP12 - Encapsulated Industrial Control Transformers .....	85
OHM's Law Equations .....	86

DONGAN ELECTRIC MANUFACTURING Co. • 2987 FRANKLIN • DETROIT, MI 48207  
800.428.2626 • 313.567.8500 • Fax 313.567.8828 • www.dongan.com







# Selecting and Sizing an Industrial Control Transformer

DONGAN ELECTRIC MANUFACTURING CO. • 2987 FRANKLIN • DETROIT, MI 48207  
800.428.2626 • 313.567.8500 • FAX 313.567.8828 • www.dongan.com

## THE IMPORTANCE OF USING AN INDUSTRIAL CONTROL TRANSFORMER

The use of an industrial control transformer is absolutely essential for the safe and reliable operation of control devices. Electromagnetic control components such as solenoids, contactors and timers place heavy demands on transformers powering them. These increased demands take place during start-up and the energizing of control sequences due to the inductive nature of most control devices. This results in very high inrush currents flowing through the transformer during start-up phases of control operation.

Dongan industrial control transformers are specifically designed for use in control circuits characterized by high inrush VA loads. When properly selected and sized, these transformers can accommodate the severe demands placed on them while maintaining adequate voltage for control component operation.

Electromagnetic control component loads are characterized by high amperage inrush currents when they are energized. This results in **inrush volt-ampere (inrush VA)** loads many times larger than nameplate VA being demanded of the transformer during start-up. Inrush VA loads can be 3 to 10 times ( in some case 20 times) higher than **sealed (steady state) VA** loads.

A general purpose transformer should not be used for control applications. They are not designed for high inrush loads. Their use could result in a serious lowering of secondary output voltage during the inrush period of 30 to 50 milliseconds. Reduced output voltage can prevent safe and normal component operation and may lead to premature failure of the transformer and connected control devices.

## DETERMINING SELECTION INRUSH VA

Transformer *Selection Inrush VA* refers to the effective load placed upon the industrial control transformer. *Selection Inrush VA* is calculated using both the sealed VA and the inrush VA. When *Selection Inrush VA* is calculated and known, the proper transformer VA can be obtained from the regulation and selection tables.

*Selection Inrush VA* is calculated by using total sealed VA and the total inrush VA. The total sealed VA is the VA the transformer must supply to the load for an extended length of time. It can be computed by adding up all the individual sealed VA of all devices in the control circuit. The inrush VA is usually available from the component manufacturer. In cases when it is not available, assume a 40% power factor to calculate from sealed VA. Total inrush VA is determined by adding up all the individual inrush VA loads of all components.

### Calculating selection inrush VA

**Method 1:** The most accurate formula for determining *Selection Inrush VA* is to calculate the total inrush VA vectorially:

**Selection Inrush VA =**

$$\sqrt{(VA \text{ sealed})^2 + (VA \text{ inrush})^2}$$

**Method 2:** While usually resulting in a slightly oversized transformer, a simpler method to determine *Selection Inrush VA* is to calculate it arithmetically:

**Selection Inrush VA =**

$$VA \text{ sealed} + VA \text{ inrush}$$



Series 50

Suffix Codes-052, -053, -054, -056, -058, -059, -134

Pages 70 - 75



Series HC

Suffix Codes-41, -44, -46, -47

Pages 76 - 79

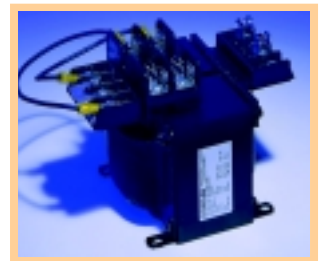

Series HC

Suffix Codes-4100, -4400

Page 77

# Selecting and Sizing an Industrial Control Transformer

## SELECTING THE CORRECT VA CAPACITY

Once *Selection Inrush VA* is calculated by one of the above methods, the selection charts below can be used. Calculated *Selection Inrush VA* should not exceed maximum inrush VA from the chart. To assure adequate capacity, a power factor of 40% has been employed in the selection chart. To assure adequate capacity, power factors of both 40% and 20% have been employed.

### SELECTION INRUSH VA CHART - SERIES 50

Series 50 Inrush VA		Selection Inrush Volt - Amperes at 85%, 90%, and 95% Of Rated Secondary Voltage					
		20% Power Factor			40% Power Factor		
		85% Sec Voltage	90% Sec Voltage	95% Sec Voltage	85% Sec Voltage	90% Sec Voltage	95% Sec Voltage
kVA Cap.	Catalog Number						
.050	50-0050-xxx	270	230	190	250	185	140
.075	50-0075-xxx	580	480	350	460	340	250
.100	50-0100-xxx	820	660	490	520	410	305
.150	50-0150-xxx	1350	1000	820	1250	900	640
.200	50-0200-xxx	1920	1380	840	1320	960	690
.250	50-0250-xxx	2780	1990	1190	1840	1290	790
.300	50-0300-xxx	3600	2680	1630	2470	1800	1070
.375	50-0375-xxx	4580	3300	2050	3100	2250	1300
.500	50-0500-xxx	6150	4450	2750	4350	3100	1900
.750	50-0750-xxx	10200	7300	4300	8450	5500	3700
1.0	50-1000-xxx	11800	8400	4600	8900	5900	3950
1.5	50-1500-xxx	22400	16300	9200	16500	12900	6900
2.0	50-2000-xxx	24600	16800	9800	19600	13300	7200
3.0	50-3000-xxx	32500	23600	13900	26500	19600	11700
5.0	50-5000-xxx	62000	46000	26800	49800	37200	29500

### SELECTION INRUSH VA CHART - SERIES HC

Series HC Inrush VA		Selection Inrush Volt - Ampere at 85%, 90%, and 95% Of Rated Secondary Voltage					
		20% Power Factor			40% Power Factor		
		85% Sec Voltage	90% Sec Voltage	95% Sec Voltage	85% Sec Voltage	90% Sec Voltage	95% Sec Voltage
kVA Cap.	Catalog Number						
.050	HC-0050-xx	270	230	190	250	185	140
.075	HC-0075-xx	580	480	350	460	340	250
.100	HC-0100-xx	810	630	440	620	530	350
.150	HC-0150-xx	1350	1050	820	1250	900	640
.250	HC-0250-xx	2040	1610	1170	1940	1420	980
.375	HC-0375-xx	3240	2450	2030	2900	2050	1650
.500	HC-0500-xx	5600	4050	2900	4500	3500	2350
.750	HC-0750-xx	9300	6650	4800	7100	5650	3850
1.0	HC-1000-xx	14500	11000	7900	12600	9700	5800
1.5	HC-1500-xx	24200	18700	13500	19500	14100	9800
2.0	HC-2000-xx	37500	27500	19800	27500	20500	14000

The use of the 90% or 95% of rated secondary voltage column is recommended for transformer selection. The use of the 85% rated secondary voltage column does not provide adequate voltage output to accommodate existing below normal distribution voltages and voltage dips and during equipment and motor start-ups.

#### Example:

Sizing Data:

Sealed VA = 270 VA

Inrush VA = 1,728 VA

Using the formula in **Method 1:**

**Selection Inrush VA**

$$= \sqrt{(VA \text{ sealed})^2 + (VA \text{ inrush})^2}$$

$$= \sqrt{(270)^2 + (1,728)^2}$$

$$= 1749 \text{ VA}$$

In above example at 95% of rated secondary voltage and 40% (.4) P.F., the correct size is 500 VA.

Using the formula in **Method 2:**

**Selection Inrush VA**

$$= VA \text{ sealed} + VA \text{ inrush}$$

$$= 270 + 1728$$

$$= 1998 \text{ VA}$$

In above example at 95% of rated secondary voltage and 40% (.4) P.F., the correct size is 750 VA.

#### Conversion to kVA

The formula used to convert VA to kVA is listed below

$$kVA = \frac{VA \text{ (Volt amperes)}}{(1000)}$$

## Series 50 Industrial Control Transformers

DONGAN ELECTRIC MANUFACTURING CO. • 2987 FRANKLIN • DETROIT, MI 48207  
 800.428.2626 • 313.567.8500 • FAX 313.567.8828 • www.dongan.com

Series 50 Industrial Control Transformers are designed to the highest NEMA and industrial standards. Series 50 offer compact designs for ease of installation in hundreds of control panel and automation applications.

All Series 50 transformers are UL approved and CSA certified.

Series 50 are available in both domestic and export voltage combinations. Other voltage, frequency and size requirements are readily manufactured by consulting the factory or your Dongan representative.

CE Marked, TÜV Licensed Industrial Control Transformers are featured on pgs. 82-83 in this section.

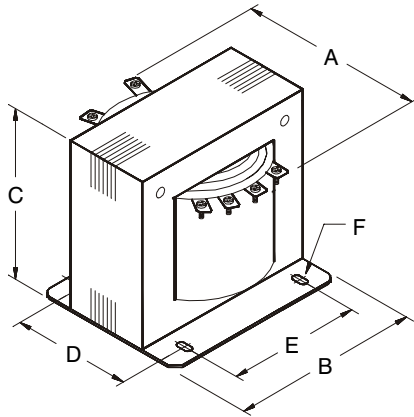

### Domestic Series:

## Features

- **UL Listed, File E3210.**
- **CSA Certified, File LR 560.**
- **All copper windings.**
- **All designs are rated 50 / 60 Hertz.**
- **Rugged coil mounted screw terminals.**
- **Primary fuse blocks and secondary fuse holders are available and are easily installed.**
- **Regulation characteristics equal or exceed the highest industry standards.**
- **Transformers .750 kVA and below employ a UL Class 105°C insulation system with 55°C temperature rise at a maximum ambient of 40°C.**
- **Transformers 1.0 kVA and above are designed with a UL Class 180°C insulation system with 115°C temperature rise at a maximum ambient of 40°C.**
- **Nonstandard designs are available by consulting the factory or your Dongan Representative.**

### Voltage Combinations:

Suffix	Primary	Secondary
-052	120 x 240	24
-053	240 x 480	120
-054	208	120
-056	600	120
-134	240 x 480	120 / 240

## SUFFIX -052, 50 / 60 HZ

Primary Volts 120 X 240, Secondary Volts 24

General Information			Dimensions (inches)						Primary		Secondary		
kVA Cap.	Catalog Number	Wgt. Lbs	Height A	Width B	Depth C	Mounting			Pri. Max. Amps 120V / 240V	Pri. Fuse Kit	Sec. Max. Amps	Sec. Fuse Kit	Sec. Fuse Size
						D	E	F					
.050	<b>50-0050-052</b>	3	3.00	3.00	2.50	2.00	2.50	.203 x .375	.42 / .21	BR-734-1	2.08	GLF 1¼	2.25
.075	<b>50-0075-052</b>	3	3.38	3.00	2.50	2.50	2.50	.203 x .375	.63 / .31	BR-734-1	3.13	GLF 1¼	3.2
.100	<b>50-0100-052</b>	4	3.38	3.38	2.81	2.38	2.81	.203 x .375	.83 / .42	BR-734-2	4.17	GLF 1¼	4.5
.150	<b>50-0150-052</b>	6	3.90	3.75	3.13	2.63	3.13	.203 x .375	1.25 / .63	BR-734-3	6.25	GLF 1¼	6.25
.200	<b>50-0200-052</b>	8	4.12	4.50	3.75	2.50	3.75	.203 x .375	1.67 / .83	BR-734-4	8.33	GLF 1¼	9
.250	<b>50-0250-052</b>	9	4.25	4.50	3.75	2.75	3.75	.203 x .375	2.08 / 1.04	BR-734-4	10.42	GLF 1¼	10
.300	<b>50-0300-052</b>	11	4.75	4.50	3.75	3.13	3.75	.203 x .375	2.50 / 1.25	BR-734-4	12.50	GLF 1¼	15
.375	<b>50-0375-052</b>	12	5.25	4.50	3.75	3.63	3.75	.203 x .375	3.13 / 1.56	BR-734-4	16.63	GLF 1¼	20
.500	<b>50-0500-052</b>	17	5.88	5.25	4.38	3.63	4.38	.281 x .562	4.17 / 2.08	BR-734-6	20.83	265 B	25
.750	<b>50-0750-052</b>	25	7.50	5.25	4.38	5.25	4.38	.281 x .562	6.25 / 3.13	BR-734-6	31.25	265 B	30
1.0	<b>50-1000-052</b>	26	7.50	5.25	4.38	5.25	4.38	.281 x .562	8.33 / 4.17	BR-734-6	41.67	--	--

# Series 50 Industrial Control Transformers

Export Series:

## Features

- **UL Listed, File E3210.**
- **CSA Certified, File LR 560.**
- All copper windings.
- All designs are rated 50 / 60 Hertz.
- Rugged coil mounted screw terminals.
- Primary fuse blocks and secondary fuse holders are available and are easily installed.
- Regulation characteristics equal or exceed the highest industry standards.
- Transformers .750 kVA and below employ a UL Class 105°C insulation system with 55°C temperature rise at a maximum ambient of 40°C.
- Transformers 1.0 kVA and above are designed with a UL Class 180°C insulation system with 115°C temperature rise at a maximum ambient of 40°C.
- Nonstandard designs are available by consulting the factory or your Dongan Representative.



Connection Diagrams may be found on Pg. 74

Note: Dimension C increases approximately 1 3/8" when Primary Fuse Kit BR-734-X is installed. Drawing is for dimensional purposes only. Actual terminal arrangements may vary.

Dimensions & weights may change. Consult factory for certified drawings.

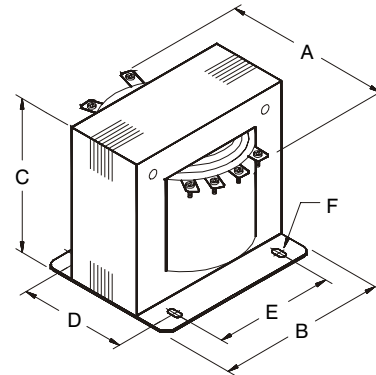

### Voltage Combinations:

Suffix	Primary	Secondary
-058	220/380/415	95/115
-059	208 or 500	85/100/110
	220/380/440/550	91/110/120
	230/400/460/575	95/115/125
	240/416/480/600	99/120/130

## SUFFIX -053, 50 / 60 HZ

Primary Volts 240 X 480, 230 X 460, 220 X 440, Secondary Volts 120/115/110

General Information			Dimensions (inches)						Primary		Secondary		
kVA Cap.	Catalog Number	Wgt. Lbs	Height A	Width B	Depth C	Mounting			Pri. Max. Amps 240V / 480V	Pri. Fuse Kit	Sec. Max. Amps	Sec. Fuse Kit	120 V Fuse Size
						D	E	F					
.050	50-0050-053	3	3.00	3.00	2.50	2.00	2.50	.203 x .375	.21 / .10	BR-734-1	.42	GLF 1¼	.5
.075	50-0075-053	3	3.38	3.00	2.50	2.50	2.50	.203 x .375	.31 / .16	BR-734-1	.63	GLF 1¼	.6
.100	50-0100-053	4	3.38	3.38	2.81	2.38	2.81	.203 x .375	.42 / .21	BR-734-2	.83	GLF 1¼	1
.150	50-0150-053	6	3.90	3.75	3.13	2.63	3.13	.203 x .375	.63 / .31	BR-734-3	1.25	GLF 1¼	1.25
.200	50-0200-053	8	4.12	4.50	3.75	2.50	3.75	.203 x .375	.83 / .42	BR-734-4	1.67	GLF 1¼	2
.250	50-0250-053	9	4.25	4.50	3.75	2.75	3.75	.203 x .375	1.04 / .52	BR-734-4	2.08	GLF 1¼	2.25
.300	50-0300-053	11	4.75	4.50	3.75	3.13	3.75	.203 x .375	1.25 / .63	BR-734-4	2.50	GLF 1¼	2.5
.375	50-0375-053	12	5.25	4.50	3.75	3.63	3.75	.203 x .375	1.56 / .78	BR-734-4	3.13	GLF 1¼	3.2
.500	50-0500-053	17	5.88	5.25	4.38	3.63	4.38	.281 x .562	2.08 / 1.04	BR-734-6	4.17	265 B	4.5
.750	50-0750-053	25	7.50	5.25	4.38	5.25	4.38	.281 x .562	3.13 / 1.56	BR-734-6	6.25	265 B	6.25
1.0	50-1000-053	26	7.50	5.25	4.38	5.25	4.38	.281 x .562	4.17 / 2.08	BR-734-6	8.33	265 B	9
1.5	50-1500-053	32	7.00	6.38	5.62	4.50	5.31	.312 x .625	6.25 / 3.13	BR-734-7	12.50	265 B	15
2.0	50-2000-053	38	7.62	6.38	5.62	5.00	5.31	.312 x .625	6.25 / 3.13	BR-734-7	16.67	265 B	20
3.0	50-3000-053	50	7.75	7.50	6.62	4.75	6.75	.312 x .625	12.50 / 6.25	BR-734-8	25.00	265 B	25
5.0	50-5000-053	70	10.25	7.50	6.62	6.88	6.75	.312 x .625	20.83 / 10.42	BR-734-8	41.67	--	--

DONGAN ELECTRIC MANUFACTURING CO. • 2987 FRANKLIN • DETROIT, MI 48207  
 800.428.2626 • 313.567.8500 • Fax 313.567.8828 • www.dongan.com



# Series 50 Industrial Control Transformers

DONGAN ELECTRIC MANUFACTURING CO. • 2987 FRANKLIN • DETROIT, MI 48207  
 800.428.2626 • 313.567.8500 • FAX 313.567.8828 • www.dongan.com

## SUFFIX -054, 50 / 60 HZ

Primary Volts 208, Secondary Volts 120

General Information			Dimensions (inches)						Primary		Secondary		
kVA Cap.	Catalog Number	Wgt. Lbs	Height A	Width B	Depth C	Mounting			Pri. Max. Amps 208V	Pri. Fuse Kit	Sec. Max. Amps	Sec. Fuse Kit	Sec. Fuse Size
						D	E	F					
.050	50-0050-054	3	3.00	3.00	2.50	2.00	2.50	.203 x .375	.24	BR-734-1	.42	GLF 1¼	.4
.075	50-0075-054	3	3.38	3.00	2.50	2.50	2.50	.203 x .375	.36	BR-734-1	.63	GLF 1¼	.6
.100	50-0100-054	4	3.38	3.38	2.81	2.38	2.81	.203 x .375	.48	BR-734-2	.83	GLF 1¼	1
.150	50-0150-054	6	3.90	3.75	3.13	2.63	3.13	.203 x .375	.72	BR-734-3	1.25	GLF 1¼	1.25
.200	50-0200-054	8	4.12	4.50	3.75	2.50	3.75	.203 x .375	.96	BR-734-4	1.67	GLF 1¼	2
.250	50-0250-054	9	4.25	4.50	3.75	2.75	3.75	.203 x .375	1.20	BR-734-4	2.08	GLF 1¼	2.25
.300	50-0300-054	11	4.75	4.50	3.75	3.13	3.75	.203 x .375	1.44	BR-734-4	2.50	GLF 1¼	2.5
.375	50-0375-054	12	5.25	4.50	3.75	3.63	3.75	.203 x .375	1.80	BR-734-4	3.13	GLF 1¼	3.2
.500	50-0500-054	17	5.88	5.25	4.38	3.63	4.38	.281 x .562	2.40	BR-734-6	4.17	265 B	4.5
.750	50-0750-054	25	7.50	5.25	4.38	5.25	4.38	.281 x .562	3.61	BR-734-6	6.25	265 B	6.25
1.0	50-1000-054	26	7.50	5.25	4.38	5.25	4.38	.281 x .562	4.81	BR-734-6	8.33	265 B	9
1.5	50-1500-054	32	7.00	6.38	5.62	4.50	5.31	.312 x .625	7.21	BR-734-7	12.50	265 B	15
2.0	50-2000-054	38	7.62	6.38	5.62	5.00	5.31	.312 x .625	9.62	BR-734-7	16.67	265 B	20
3.0	50-3000-054	50	7.75	7.50	6.62	4.75	6.75	.312 x .625	14.42	BR-734-8	25.00	265 B	25

Connection Diagrams may be found on Pg. 74

Note: Dimension C increases approximately 1 3/8" when Primary Fuse Kit BR-734-X is installed. Drawing is for dimensional purposes only. Actual terminal arrangements may vary.

Dimensions & weights may change. Consult factory for certified drawings.

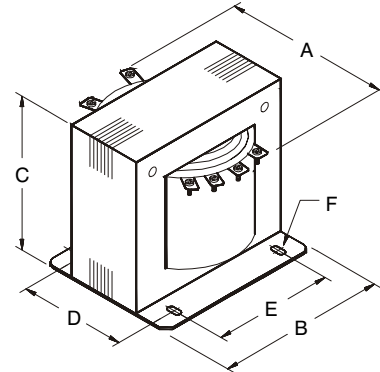

## SUFFIX -056, 50 / 60 HZ

Primary Volts 600/575/550, Secondary Volts 120/115/110

General Information			Dimensions (inches)						Primary		Secondary		
kVA Cap.	Catalog Number	Wgt. Lbs	Height A	Width B	Depth C	Mounting			Pri. Max. Amps 600V	Pri. Fuse Kit	Sec. Max. Amps	Sec. Fuse Kit	120 V Fuse Size
						D	E	F					
.050	50-0050-056	3	3.00	3.00	2.50	2.00	2.50	.203 x .375	.08	BR-734-1	.42	GLF 1¼	.4
.075	50-0075-056	3	3.38	3.00	2.50	2.50	2.50	.203 x .375	.13	BR-734-1	.63	GLF 1¼	.6
.100	50-0100-056	4	3.38	3.38	2.81	2.38	2.81	.203 x .375	.17	BR-734-2	.83	GLF 1¼	1
.150	50-0150-056	6	3.90	3.75	3.13	2.63	3.13	.203 x .375	.25	BR-734-3	1.25	GLF 1¼	1.25
.200	50-0200-056	8	4.12	4.50	3.75	2.50	3.75	.203 x .375	.33	BR-734-4	1.67	GLF 1¼	2
.250	50-0250-056	9	4.25	4.50	3.75	2.75	3.75	.203 x .375	.42	BR-734-4	2.08	GLF 1¼	2.25
.300	50-0300-056	11	4.75	4.50	3.75	3.13	3.75	.203 x .375	.50	BR-734-4	2.50	GLF 1¼	2.5
.375	50-0375-056	12	5.25	4.50	3.75	3.63	3.75	.203 x .375	.63	BR-734-4	3.13	GLF 1¼	3.2
.500	50-0500-056	17	5.88	5.25	4.38	3.63	4.38	.281 x .562	.83	BR-734-6	4.17	265 B	4.5
.750	50-0750-056	25	7.50	5.25	4.38	5.25	4.38	.281 x .562	1.25	BR-734-6	6.25	265 B	6.25
1.0	50-1000-056	26	7.50	5.25	4.38	5.25	4.38	.281 x .562	1.67	BR-734-6	8.33	265 B	9
1.5	50-1500-056	32	7.00	6.38	5.62	4.50	5.31	.312 x .625	2.50	BR-734-7	12.50	265 B	15
2.0	50-2000-056	38	7.62	6.38	5.62	5.00	5.31	.312 x .625	3.33	BR-734-7	16.67	265 B	20
3.0	50-3000-056	50	7.75	7.50	6.62	4.75	6.75	.312 x .625	5.00	BR-734-8	25.00	265 B	25





# Series 50 Industrial Control Transformers

## SUFFIX -058, 50 / 60 HZ

Primary Volts 220 / 380 / 415, Secondary Volts 95 / 115

General Information			Dimensions (inches)						Primary		Secondary		
kVA Cap.	Catalog Number	Wgt. Lbs	Height A	Width B	Depth C	Mounting			Pri. Max. Amps 220V / 380V / 415	Pri. Fuse Kit	Sec. Max. Amps	Sec. Fuse Kit	115 V Fuse Size
						D	E	F					
.250	50-0250-058	11	4.81	4.50	3.75	3.38	3.75	.203 x .375	1.14 / .66 / .60	BR-734-4	2.17	GLF 1¼	2.25
.500	50-0500-058	22	6.63	5.25	4.38	4.60	4.38	.281 x .406	2.27 / 1.32 / 1.20	BR-734-6	4.35	265 B	4.5
.750	50-0750-058	23	7.38	5.75	4.25	4.38	4.94	.281 x .406	3.41 / 1.97 / 1.81	BR-734-5	6.52	265 B	7
1.0	50-1000-058	32	6.75	6.38	5.31	4.50	5.31	.312 x .625	4.55 / 2.63 / 2.41	BR-734-7	8.70	265 B	9
1.5	50-1500-058	41	6.25	7.50	6.25	4.00	6.75	.312 x .625	6.82 / 3.95 / 3.61	BR-734-8	13.04	265 B	15
2.0	50-2000-058	49	7.80	7.50	6.25	4.75	6.75	.312 x .625	9.09 / 5.26 / 4.82	BR-734-8	17.39	265 B	20
3.0	50-3000-058	75	9.88	7.50	6.25	4.62	6.75	.312 x .625	13.64 / 7.89 / 7.23	BR-734-8	26.09	265 B	30
5.0	50-5000-058	113	9.12	9.00	7.50	6.93	7.50	.437 x .750	22.73 / 13.16 / 12.05	BR-734-9	43.48	--	--

## SUFFIX -059, 50 / 60 HZ

Primary Volts 208/500  
220/380/440/550  
230/400/460/575  
240/416/480/600

Secondary Volts 85/100/110  
91/110/120  
95/115/125  
99/120/130

General Information			Dimensions (inches)						Primary	Secondary		
kVA Cap.	Catalog Number	Wgt. Lbs	Height A	Width B	Depth C	Mounting			Pri. Fuse Kit	Sec. Max. Amps	Sec. Fuse Kit	120 V Fuse Size
						D	E	F				
.150	50-0150-059	11	4.57	5.25	4.38	2.63	4.38	.281 x .406	BR-734-6	1.25	265 B	1.25
.250	50-0250-059	15	5.25	5.25	4.38	3.38	4.38	.281 x .406	BR-734-6	2.08	265 B	2.25
.375	50-0375-059	18	6.25	5.75	4.25	3.44	4.94	.281 x .406	BR-734-5	3.13	265 B	3.2
.500	50-0500-059	22	6.68	5.75	4.25	4.38	4.94	.281 x .406	BR-734-5	4.17	265 B	4.5
.750	50-0750-059	32	6.75	6.38	5.31	4.63	5.31	.312 x .625	BR-734-7	6.25	265 B	6.25
1.0	50-1000-059	35	7.25	6.38	5.31	5.10	5.31	.312 x .625	BR-734-7	8.33	265 B	9
1.5	50-1500-059	53	8.63	7.50	6.25	5.38	6.75	.312 x .625	BR-734-8	12.5	265 B	15
2.0	50-2000-059	60	8.75	7.50	6.25	5.80	6.75	.312 x .625	BR-734-8	16.67	265 B	20
3.0	50-3000-059	74	10.25	7.50	6.25	6.88	6.75	.312 x .625	BR-734-8	25.00	265 B	25

## SUFFIX -134, 50 / 60 HZ

Primary Volts 240 X 480, 230 X 460, 220 X 440,  
Secondary Volts 120/240,115/230,110/220

General Information			Dimensions (inches)						Primary		Secondary		
kVA Cap.	Catalog Number	Wgt. Lbs	Height A	Width B	Depth C	Mounting			Pri. Max. Amps 240V / 480V	Pri. Fuse Kit	Sec. Max. Amps 120V / 240V	Sec. Fuse Kit	120 V Fuse Size
						D	E	F					
.050	50-0050-134	3	3.00	3.00	2.50	2.00	2.50	.203 x .375	.21 / .10	BR-734-1	.42 / .21	GLF 1¼	.5
.075	50-0075-134	3	3.38	3.00	2.50	2.50	2.50	.203 x .375	.31 / .16	BR-734-1	.63 / .31	GLF 1¼	.6
.100	50-0100-134	4	3.38	3.38	2.81	2.38	2.81	.203 x .375	.42 / .21	BR-734-2	.83 / .42	GLF 1¼	1
.150	50-0150-134	6	3.90	3.75	3.13	2.63	3.13	.203 x .375	.63 / .31	BR-734-3	1.25 / .63	GLF 1¼	1.25
.200	50-0200-134	8	4.12	4.50	3.75	2.50	3.75	.203 x .375	.83 / .42	BR-734-4	1.67 / .83	GLF 1¼	2
.250	50-0250-134	9	4.25	4.50	3.75	2.75	3.75	.203 x .375	1.04 / .52	BR-734-4	2.08 / 1.04	GLF 1¼	2.25
.300	50-0300-134	11	4.75	4.50	3.75	3.13	3.75	.203 x .375	1.25 / .63	BR-734-4	2.50 / 1.25	GLF 1¼	2.5
.375	50-0375-134	12	5.25	4.50	3.75	3.63	3.75	.203 x .375	1.56 / .78	BR-734-4	3.13 / 1.56	GLF 1¼	3.2
.500	50-0500-134	17	5.88	5.25	4.38	3.63	4.38	.281 x .562	2.08 / 1.04	BR-734-6	4.17 / 2.08	265 B	4.5
.750	50-0750-134	25	7.50	5.25	4.38	5.25	4.38	.281 x .562	3.13 / 1.56	BR-734-6	6.25 / 3.13	265 B	6.25
1.0	50-1000-134	26	7.50	5.25	4.38	5.25	4.38	.281 x .562	4.17 / 2.08	BR-734-6	8.33 / 4.17	265 B	9
1.5	50-1500-134	32	7.00	6.38	5.62	4.50	5.31	.312 x .625	6.25 / 3.13	BR-734-7	12.50 / 6.25	265 B	15
2.0	50-2000-134	38	7.62	6.38	5.62	5.00	5.31	.312 x .625	6.25 / 3.13	BR-734-7	16.67 / 8.33	265 B	20
3.0	50-3000-134	50	7.75	7.50	6.62	4.75	6.75	.312 x .625	12.50 / 6.25	BR-734-8	25.00 / 12.50	265 B	25

DONGAN ELECTRIC MANUFACTURING CO. • 2987 FRANKLIN • DETROIT, MI 48207  
 800.428.2626 • 313.567.8500 • FAX 313.567.8828 • www.dongan.com

# Series 50 Industrial Control Transformers Connection Diagrams

DONGAN ELECTRIC MANUFACTURING CO. • 2987 FRANKLIN • DETROIT, MI 48207  
 800.428.2626 • 313.567.8500 • FAX 313.567.8828 • www.dongan.com

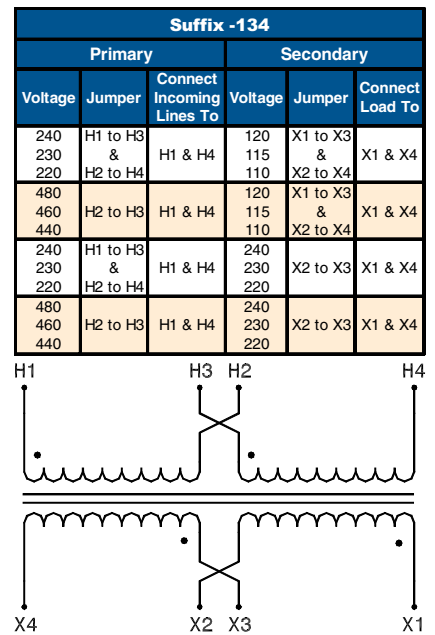
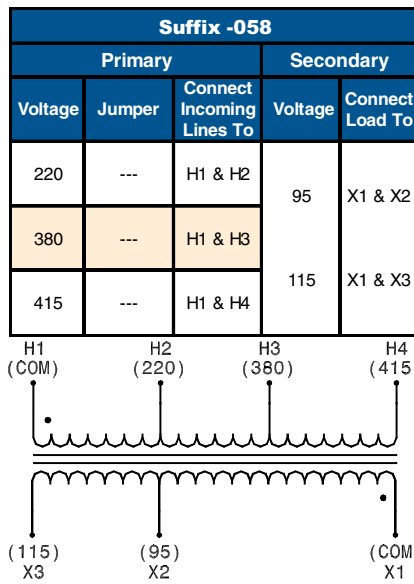
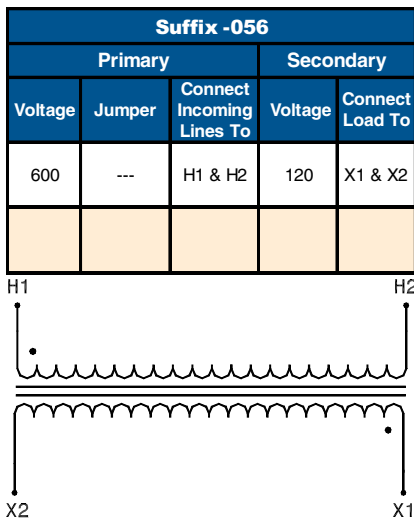
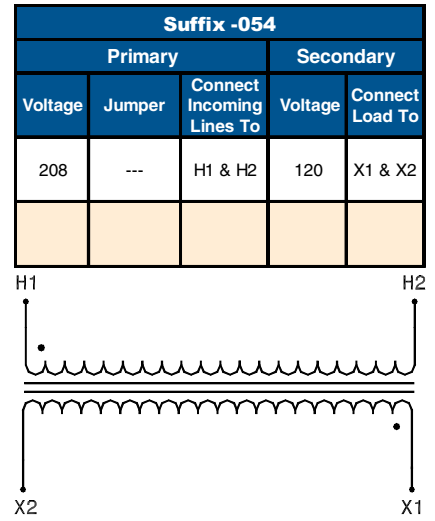
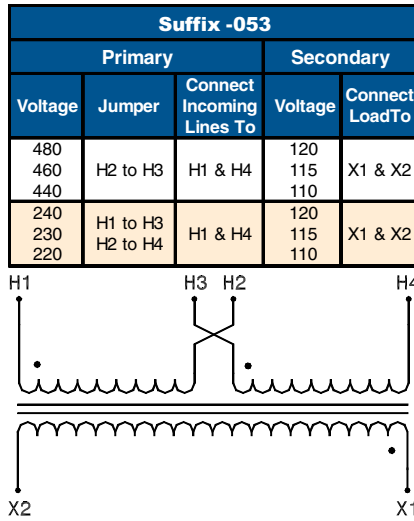
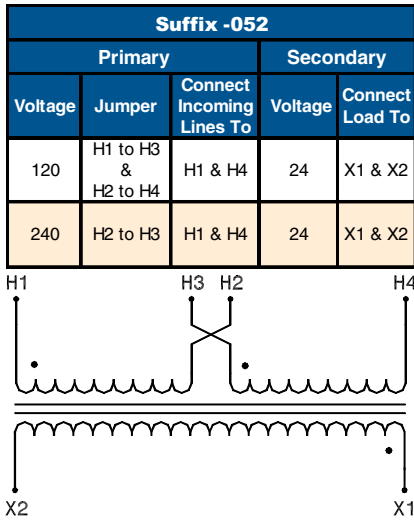

Suffix -059						
Primary				Secondary		
Connect Incoming Lines To H1 & H2	Connect Incoming Lines To H1 & H3	Connect Incoming Lines To H1 & H4	Connect Incoming Lines To H1 & H5	Connect Load To X1 & X2	Connect Load To X1 & X3	Connect Load To X1 & X4
208			500	85	100	110
220	380	440	550	91	110	120
230	400	460	575	95	115	125
240	416	480	600	99	120	130

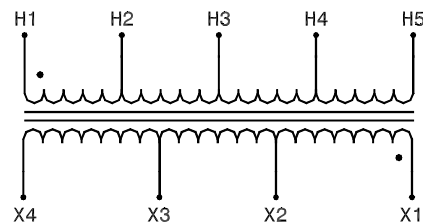

## Series 50 Industrial Control Transformers

### SERIES 50 PRIMARY FUSE KIT

#### Fuse Kit BR-734

- Meets UL 508
- Meets NEC Article 450
- Uses Class CC Fuses

##### Installation Procedure

- Loosen bolts holding transformer to the panel backplate.
- Slide the BR-734 bracket over the transformer.
- Retighten mounting bolts.
- Connect the fuse holder leads to the transformer terminals with the jumper leads furnished.

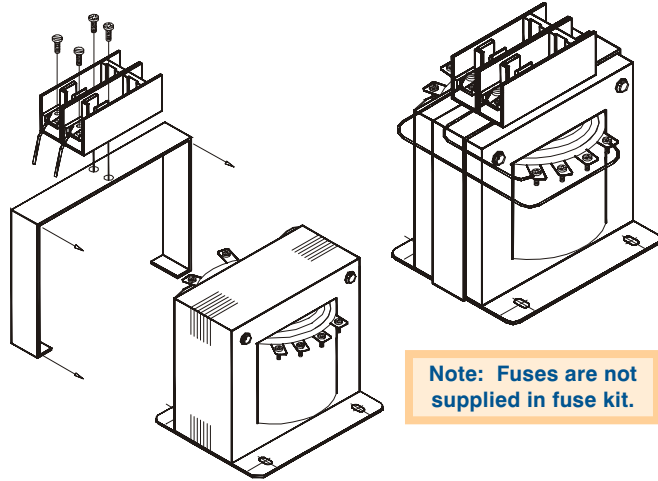

### SERIES 50 SECONDARY FUSE KITS

#### Fuse Kit GLF 1 1/4

- Meets UL 508
- Meets NEC Article 450
- Uses 1/4" x 1 1/4" Fuses

##### Installation Procedure

- Remove #6 screw in the transformer terminal to be fused.
- Fasten GLF 1 1/4 fuse holder to transformer terminal with the longer #6 screw provided, as shown in the diagram.
- Connect the load lead to the terminal provided on the GLF 1 1/4 fuse holder.

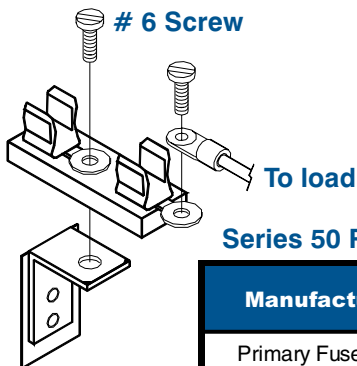

#### Fuse Kit 265B

- Meets UL 508
- Meets NEC Article 450
- Uses 13/32" x 1 1/2" Fuses

##### Installation Procedure

- Remove #10 screw in the transformer terminal to be fused.
- Fasten 265B fuse holder to transformer terminal with the longer #10 screw provided, as shown in the diagram.
- Connect the load lead to the terminal provided on the 265B fuse holder.

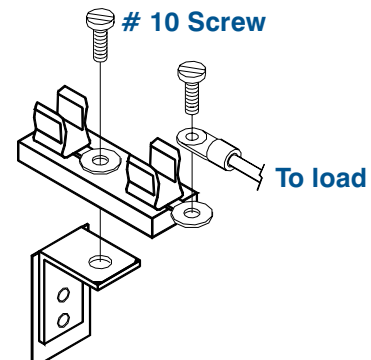

##### Series 50 Recommended Fuse Type By Manufacturer

Manufacturer	Bussman	Gould	Littlefuse
Primary Fuse Type	FNQ-R	ATQR / ATDR	KLDR / CCRM
Secondary Fuse Type Fuse Holder 265-B	FNM / FNQ (250V) (500V)	TRM / ATQ (250V) (500V)	FLM / FLQ (250V) (500V)
Secondary Fuse Type Fuse Holder GLF-1 1/4	MDQ (250V)	GDL (250V)	3AB (250V)

## Series HC Industrial Control Transformers

DONGAN ELECTRIC MANUFACTURING CO. • 2987 FRANKLIN • DETROIT, MI 48207  
 800.428.2626 • 313.567.8500 • FAX 313.567.8828 • www.dongan.com

Series HC Industrial Control Transformers feature a molded, barrier type terminal board for easy connections of both line and load as well as various fusing kits for both primary and secondary. In addition, Series HC offer convenient jumper clips for series/parallel connections. These features allow the designer to simplify control panel fusing designs and minimize transformer installation time and cost.

Series suffix -4100 and -4400 are conveniently shipped with both primary and secondary fuse holders installed, allowing further cost reduction to the OEM.

All Series HC transformers are UL approved and CSA certified. CE Marked, TÜV Licensed Industrial Control Transformers are featured on pgs. 82 - 83 in this section.

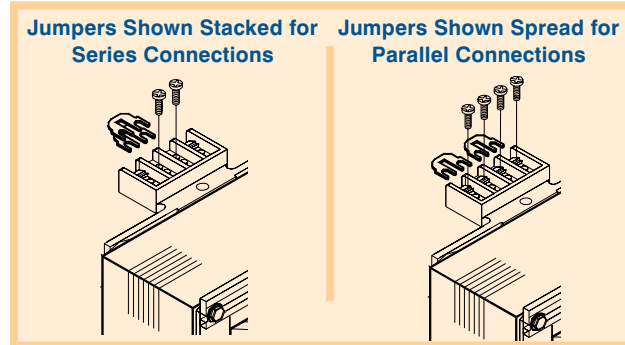

Series HC are shipped with Jumper Clips connected in series.

## Features

- **UL Listed, File E3210.**
- **CSA Certified, File LR 560.**
- All copper windings.
- Core mounted, barrier type terminal strips.
- Series/parallel jumper clips provided.
- Secondary fuse kits (FKS) furnished.
- Primary fuse kits (FKP2) are available and are easily installed.
- Regulation characteristics equal or exceed the highest industry standards.
- Grain oriented, silicon steel cores minimize core losses.
- Transformers .050 kVA to .150 kVA employ a UL Class 180°C insulation system with 55°C temperature rise at a maximum ambient of 40°C.
- Transformers .250 kVA and above are designed with a UL Class 180°C insulation system with 115°C temperature rise at a maximum ambient of 40°C.
- Nonstandard designs are available by consulting the factory or your Dongan Representative.

### Voltage Combinations:

Suffix	Primary	Secondary
-41	240 x 480	120
-44	208 / 240 / 480	120
-46	600	120
-47	240 / 480 / 600	120

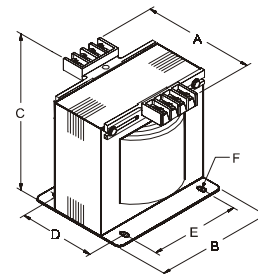

Outline Drawing  
HC Suffix -41,-44,-46,-47

## SUFFIX -41

Primary Volts 240 X 480, 230 X 460, 220 X 440, Secondary Volts 120/115/110

General Information			Dimensions (inches)						Primary		Secondary			
kVA Cap.	Catalog Number	Hz.	Wgt. Lbs	Height A	Width B	Depth C	Mounting			Pri. Max. Amps 240V / 480V	Pri. Fuse Kit	Sec. Max. Amps	Sec. Fuse Kit	Sec. Fuse Size
							D	E	F					
.050	HC-0050-41	50/60	3.0	4.75	3.00	3.25	2.00	2.50	.203 x .375	.21 / .10	FKP2	.42	Included	.5
.075	HC-0075-41	50/60	4.0	5.25	3.00	3.25	2.50	2.50	.203 x .375	.31 / .16	FKP2	.63	Included	.6
.100	HC-0100-41	50/60	5.0	5.62	3.00	3.25	2.87	2.50	.203 x .375	.42 / .21	FKP2	.83	Included	1
.150	HC-0150-41	50/60	7.0	5.25	3.75	3.75	2.62	3.13	.203 x .375	.63 / .31	FKP2	1.25	Included	1.25
.250	HC-0250-41	50/60	8.5	5.62	3.75	3.75	2.87	3.13	.203 x .375	1.04 / .52	FKP2	2.08	Included	2.25
.300	HC-0300-41	50/60	9.5	6.00	3.75	3.75	3.25	3.13	.203 x .375	1.25 / .63	FKP2	2.50	Included	2.5
.375	HC-0375-41	50/60	10.0	5.50	4.50	4.30	2.80	3.80	.203 x .375	1.56 / .78	FKP2	3.13	Included	3.2
.500	HC-0500-41	50/60	11.5	6.00	4.50	4.25	3.25	3.75	.203 x .375	2.08 / 1.04	FKP2	4.17	Included	4.5
.750	HC-0750-41	50/60	15.5	6.87	4.50	4.25	4.12	3.75	.203 x .375	3.12 / 1.56	FKP2	6.25	Included	6.25
1.0	HC-1000-41	60	19.0	6.50	5.25	4.87	3.87	4.37	.281 x .562	4.16 / 2.08	FKP2	8.33	Included	9
1.5	HC-1500-41	60	27.0	7.87	5.25	4.87	5.12	4.37	.281 x .562	6.25 / 3.12	FKP2	12.50	Included	15
2.0	HC-2000-41	60	31.5	9.12	5.25	4.87	6.4	4.37	.281 x .562	8.33 / 4.16	FKP2	16.67	Included	20

# Series HC Industrial Control Transformers

## SUFFIX -4100 & -4400

### Features

- UL Listed, File E3210.
- CSA Certified, File LR 560.

Series -4100, and -4400: Factory Pre-Connected Primary & Secondary Fusing

- All copper windings.
- Core mounted, barrier type terminal strips.
- Series/parallel jumper clips provided on -4100.
- Dual primary fuse holder and single secondary fuse holder are factory assembled for added convenience.
- Regulation characteristics equal or exceed the highest industry standards.

- Grain oriented, silicon steel cores minimize core losses.
- Transformers .050 kVA to .150 kVA employ a UL Class 180°C insulation system with 55°C temperature rise at a maximum ambient of 40°C.
- Transformers .250 kVA and above are designed with a UL Class 180°C insulation system with 115°C temperature rise at a maximum ambient of 40°C.
- Nonstandard designs are available by consulting the factory or your Dongan Representative.

#### Voltage Combinations:

Suffix	Primary	Secondary
-4100	240 x 480	120
-4400	208 / 240 / 480	120

## SUFFIX -4100 WITH PRE-CONNECTED DUAL PRIMARY FUSE BLOCKS & SECONDARY FUSE HOLDER

Primary Volts 240 X 480, 230 X 460, 220 X 440,  
Secondary Volts 120/115/110

General Information				Dimensions (inches)						Primary		Secondary		
kVA Cap.	Catalog Number	Hz.	Wgt. Lbs	Height A	Width B	Depth C	Mounting			Pri. Max. Amps 240V / 480V	Pri. Fuse Kit	Sec. Max. Amps	Sec. Fuse Kit	Sec. Fuse Size
							D	E	F					
.050	HC-0050-4100	50/60	3.0	4.75	3.00	4.25	2.00	2.50	.203 x .375	.21 / .10	Installed	.42	Included	.5
.075	HC-0075-4100	50/60	4.0	5.25	3.00	4.25	2.50	2.50	.203 x .375	.31 / .16	Installed	.63	Included	.6
.100	HC-0100-4100	50/60	5.0	5.62	3.00	4.25	2.87	2.50	.203 x .375	.42 / .21	Installed	.83	Included	1
.150	HC-0150-4100	50/60	7.0	5.25	3.75	4.75	2.62	3.13	.203 x .375	.63 / .31	Installed	1.25	Included	1.25
.250	HC-0250-4100	50/60	8.5	5.62	3.75	4.75	2.87	3.13	.203 x .375	1.04 / .52	Installed	2.08	Included	2.25
.300	HC-0300-4100	50/60	9.5	6.00	3.75	4.75	2.87	3.13	.203 x .375	1.25 / .63	Installed	2.50	Included	2.5
.375	HC-0375-4100	50/60	10.0	5.30	4.50	5.30	2.80	3.80	.203 x .375	1.56 / .78	Installed	3.13	Included	3.2
.500	HC-0500-4100	50/60	11.5	6.00	4.50	5.25	3.25	3.75	.203 x .375	2.08 / 1.04	Installed	4.17	Included	4.5
.750	HC-0750-4100	50/60	15.5	6.87	4.50	5.25	4.12	3.75	.203 x .375	3.12 / 1.56	Installed	6.25	Included	6.25
1.0	HC-1000-4100	60	19.0	6.50	5.25	5.87	3.87	4.37	.281 x .562	4.16 / 2.08	Installed	8.33	Included	9
1.5	HC-1500-4100	60	27.0	7.87	5.25	5.87	5.12	4.37	.281 x .562	6.25 / 3.12	Installed	12.50	Included	15
2.0	HC-2000-4100	60	31.5	9.12	5.25	5.87	6.43	4.37	.281 x .562	8.33 / 4.16	Installed	16.67	Included	20

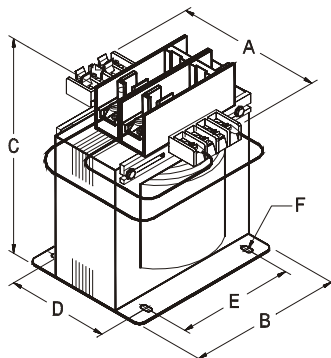

Outline Drawing  
HC Suffix -4100, -4400

Connection Diagrams may be found on  
Pg. 80





# Series HC Industrial Control Transformers

DONGAN ELECTRIC MANUFACTURING CO. • 2987 FRANKLIN • DETROIT, MI 48207  
 800.428.2626 • 313.567.8500 • FAX 313.567.8828 • www.dongan.com

## SUFFIX -44

Primary Volts 208/240/480, Secondary Volts 120

General Information			Dimensions (inches)						Primary		Secondary			
kVA Cap.	Catalog Number	Hz.	Wgt. Lbs	Height A	Width B	Depth C	Mounting			Pri. Max. Amps 208/240V/480V	Pri. Fuse Kit	Sec. Max. Amps	Sec. Fuse Kit	Sec. Fuse Size
							D	E	F					
.050	HC-0050-44	50/60	3.0	5.00	3.00	3.25	2.25	2.50	.203 x .375	.24 / .21 / .10	FKP2	.42	Included	.5
.075	HC-0075-44	50/60	4.0	5.62	3.00	3.25	2.87	2.50	.203 x .375	.36 / .31 / .16	FKP2	.63	Included	.6
.100	HC-0100-44	50/60	5.5	5.25	3.75	3.75	2.50	3.13	.203 x .375	.48 / .42 / .21	FKP2	.83	Included	1
.150	HC-0150-44	50/60	7.5	6.12	3.75	3.75	3.31	3.12	.203 x .375	.72 / .63 / .31	FKP2	1.25	Included	1.25
.250	HC-0250-44	50/60	8.5	5.25	4.50	4.30	2.50	3.75	.203 x .375	1.21 / 1.04 / .52	FKP2	2.08	Included	2.25
.300	HC-0300-44	50/60	10.5	6.00	4.50	4.30	3.25	3.75	.203 x .375	1.4 / 1.25 / .63	FKP2	2.50	Included	2.5
.375	HC-0375-44	50/60	11.5	6.00	4.50	4.30	3.25	3.75	.203 x .375	1.8 / 1.56 / .78	FKP2	3.13	Included	3.2
.500	HC-0500-44	50/60	13.5	6.50	4.50	4.30	3.75	3.75	.203 x .375	2.4 / 2.08 / 1.04	FKP2	4.17	Included	4.5
.750	HC-0750-44	50/60	18.5	6.50	5.25	4.87	3.75	4.37	.203 x .375	3.6 / 3.12 / 1.56	FKP2	6.25	Included	6.25
1.0	HC-1000-44	60	20.0	6.75	5.25	4.87	4.00	4.37	.281 x .562	4.8 / 4.16 / 2.08	FKP2	8.33	Included	9
1.5	HC-1500-44	60	29.5	8.50	5.25	4.87	5.87	4.37	.281 x .562	7.2 / 6.25 / 3.12	FKP2	12.50	Included	15
2.0	HC-2000-44	60	32.0	8.50	4.25	6.25	5.93	3.43	.281 x .562	9.6 / 4.17 / 4.16	FKP2	16.67	Included	20

## SUFFIX -4400

With Pre-Connected Dual Primary Fuse Blocks & Secondary Fuse Holder\*

Primary Volts 208/240/480, Secondary Volts 120

General Information			Dimensions (inches)						Primary		Secondary			
kVA Cap.	Catalog Number	Hz.	Wgt. Lbs	Height A	Width B	Depth C	Mounting			Pri. Max. Amps 208/240V/480V	Pri. Fuse Kit*	Sec. Max. Amps	Sec. Fuse Kit	Sec. Fuse Size
							D	E	F					
.050	HC-0050-4400	50/60	3.0	5.00	3.00	4.25	2.25	2.50	.203 x .375	.24 / .21 / .10	Installed	.42	Included	.5
.075	HC-0075-4400	50/60	4.0	5.62	3.00	4.25	2.87	2.50	.203 x .375	.36 / .31 / .16	Installed	.63	Included	.6
.100	HC-0100-4400	50/60	5.5	5.25	3.75	4.75	2.50	3.12	.203 x .375	.48 / .42 / .21	Installed	.83	Included	1
.150	HC-0150-4400	50/60	7.5	6.12	3.75	4.75	3.31	3.12	.203 x .375	.72 / .63 / .31	Installed	1.25	Included	1.25
.250	HC-0250-4400	50/60	8.5	5.25	4.50	5.50	2.50	3.75	.203 x .375	1.21 / 1.04 / .52	Installed	2.08	Included	2.25
.300	HC-0300-4400	50/60	9.5	6.00	4.50	5.50	3.25	3.75	.203 x .375	1.4 / 1.25 / .63	Installed	2.50	Included	2.5
.375	HC-0375-4400	50/60	11.5	6.00	4.50	5.50	3.25	3.75	.203 x .375	1.8 / 1.56 / .78	Installed	3.13	Included	3.2
.500	HC-0500-4400	50/60	13.5	6.50	4.50	5.50	3.75	3.75	.203 x .375	2.4 / 2.08 / 1.04	Installed	4.17	Included	4.5
.750	HC-0750-4400	50/60	18.5	6.50	5.25	6.25	3.75	4.37	.203 x .375	3.6 / 3.12 / 1.56	Installed	6.25	Included	6.25
1.0	HC-1000-4400	60	20.0	6.75	5.25	6.25	4.00	4.37	.281 x .562	4.8 / 4.16 / 2.08	Installed	8.33	Included	9
1.5	HC-1500-4400	60	29.5	8.50	5.25	6.25	5.87	4.37	.281 x .562	7.2 / 6.25 / 3.12	Installed	12.50	Included	15
2.0	HC-2000-4400	60	32.0	8.50	4.25	5.25	5.93	3.43	.281 x .562	9.6 / 4.17 / 4.16	Installed	16.67	Included	20

\*Fuse block is factory preconnected on 480 volt terminals.

## SUFFIX -46

Primary Volts 600/575/550, Secondary Volts 120/115/110

General Information			Dimensions (inches)						Primary		Secondary			
kVA Cap.	Catalog Number	Hz.	Wgt. Lbs	Height A	Width B	Depth C	Mounting			Pri. Max. Amps 600V	Pri. Fuse Kit	Sec. Max. Amps	Sec. Fuse Kit	Sec. Fuse Size
							D	E	F					
.050	HC-0050-46	50/60	3.0	4.75	3.00	3.25	2.00	2.50	.203 x .375	.08	FKP2	.42	Included	.5
.075	HC-0075-46	50/60	4.0	5.25	3.00	3.25	2.50	2.50	.203 x .375	.13	FKP2	.63	Included	.6
.100	HC-0100-46	50/60	5.0	5.62	3.00	3.25	2.87	2.50	.203 x .375	.17	FKP2	.83	Included	1
.150	HC-0150-46	50/60	7.0	5.25	3.75	3.75	2.62	3.13	.203 x .375	.25	FKP2	1.25	Included	1.25
.250	HC-0250-46	50/60	8.5	5.62	3.75	3.75	2.87	3.13	.203 x .375	.42	FKP2	2.08	Included	2.25
.300	HC-0300-46	50/60	9.5	6.00	3.75	3.75	3.25	3.13	.203 x .375	.50	FKP2	2.50	Included	2.5
.375	HC-0375-46	50/60	10.0	5.30	4.50	4.30	2.80	3.80	.203 x .375	.63	FKP2	3.13	Included	3.2
.500	HC-0500-46	50/60	11.5	6.00	4.50	4.25	3.25	3.75	.203 x .375	.83	FKP2	4.17	Included	4.5
.750	HC-0750-46	50/60	15.5	6.87	4.50	4.25	4.12	3.75	.203 x .375	1.3	FKP2	6.25	Included	6.25
1.0	HC-1000-46	60	19.0	6.50	5.25	4.87	3.87	4.37	.281 x .562	1.7	FKP2	8.33	Included	9
1.5	HC-1500-46	60	27.0	7.87	5.25	4.87	5.12	4.37	.281 x .562	2.5	FKP2	12.50	Included	15
2.0	HC-2000-46	60	31.5	9.12	5.25	4.87	6.43	4.37	.281 x .562	3.3	FKP2	16.67	Included	20

# Series HC Industrial Control Transformers

## SUFFIX -47

Primary Volts 240/480/600, Secondary Volts 120

General Information			Dimensions (inches)						Primary			Secondary		
kVA Cap.	Catalog Number	Hz.	Wgt. Lbs	Height A	Width B	Depth C	Mounting			Pri. Max. Amps 240/480/600V	Pri. Fuse Kit	Sec. Max. Amps	Sec. Fuse Kit	Sec. Fuse Size
							D	E	F					
.050	HC-0050-47	50/60	3.0	5.00	3.00	3.25	2.25	2.50	.203 x .375	.21 / .10 / .08	FKP2	.42	Included	.5
.075	HC-0075-47	50/60	4.0	5.62	3.00	3.25	2.87	2.50	.203 x .375	.31 / .16 / .13	FKP2	.63	Included	.6
.100	HC-0100-47	50/60	5.5	5.25	3.75	3.75	2.50	3.12	.203 x .375	.42 / .21 / .17	FKP2	.83	Included	1
.150	HC-0150-47	50/60	7.5	6.12	3.75	3.75	3.31	3.12	.203 x .375	.63 / .31 / .25	FKP2	1.25	Included	1.25
.250	HC-0250-47	50/60	8.5	5.25	4.50	4.30	2.50	3.75	.203 x .375	1.0 / .52 / .42	FKP2	2.08	Included	2.25
.300	HC-0300-47	50/60	10.5	6.00	4.50	4.30	3.25	3.75	.203 x .375	1.25 / .63 / .50	FKP2	2.50	Included	2.5
.375	HC-0375-47	50/60	11.5	6.00	4.50	4.30	3.25	3.75	.203 x .375	1.6 / .78 / .63	FKP2	3.13	Included	3.2
.500	HC-0500-47	50/60	13.5	6.50	4.50	4.30	3.75	3.75	.203 x .375	2.1 / 1.0 / .83	FKP2	4.17	Included	4.5
.750	HC-0750-47	50/60	18.5	6.50	5.25	4.87	3.75	4.37	.203 x .375	3.1 / 1.6 / 1.3	FKP2	6.25	Included	6.25
1.0	HC-1000-47	60	20.0	6.75	5.25	4.87	4.00	4.37	.281 x .562	4.2 / 2.1 / 1.7	FKP2	8.33	Included	9
1.5	HC-1500-47	60	29.5	8.50	5.25	4.87	5.87	4.37	.281 x .562	6.3 / 3.1 / 2.5	FKP2	12.50	Included	15
2.0	HC-2000-47	60	32.0	8.50	4.25	6.25	5.93	3.43	.281 x .562	8.3 / 4.2 / 3.3	FKP2	16.67	Included	20

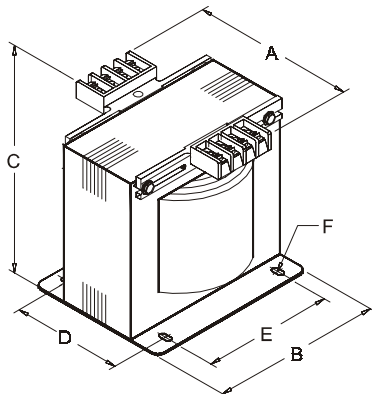

Outline Drawing  
HC Suffix -41, -44, -46, -47

Connection  
Diagrams  
may be  
found  
on Pg. 80

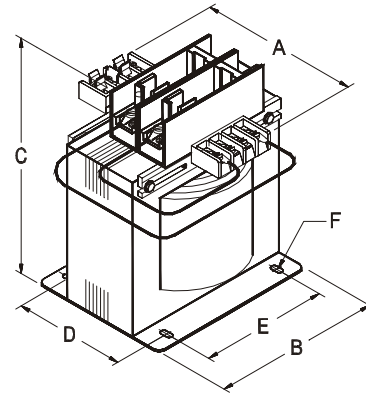

Outline Drawing  
HC Suffix -4100, -4400

## SERIES HC PRIMARY FUSE KIT

### Fuse Kit FKP2

- Meets UL 508
- Meets NEC® Article 450
- Uses Class CC Fuses

#### Installation Procedure

- Locate the mounting hole in the terminal block of primary side of transformer.
- Fasten FKP2 fuse holder to primary side of transformer terminal block with the screw provided.
- Connect the fuse holder leads to the transformer terminals with the jumper leads furnished.

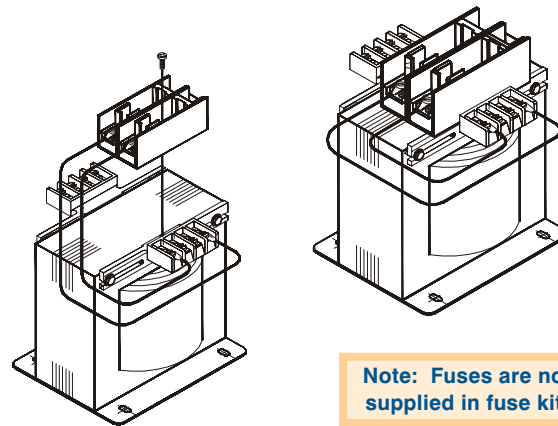

Note: Fuses are not supplied in fuse kit.

#### Series HC Recommended Fuse Type By Manufacturer

Manufacturer	Bussman	Gould	Littlefuse
Primary Fuse Type	FNQ-R	ATQR / ATDR	KLDR / CCRM
Secondary Fuse Type	FNM / FNQ (250V) (500V)	TRM / ATQ (250V) (500V)	FLM / FLQ (250V) (500V)

DONGAN ELECTRIC MANUFACTURING CO. • 2987 FRANKLIN • DETROIT, MI 48207  
 800.428.2626 • 313.567.8500 • Fax 313.567.8828 • www.dongan.com

## Fuse Kit FKS

- Meets UL 508
- Meets NEC® Article 450
- Uses 13/32" x 1 1/2" Fuses

### Installation Procedure

- To fuse terminal X1, remove #10 screws in terminals X1, XF, and unmarked terminal slot.
- Fasten fuse clip to transformer terminal X1 using #10 screw.
- Fasten #10 screw through Fuse Clip, and Jumper Terminal and into unmarked terminal slot.
- Fasten #10 screw through Jumper Terminal and into terminal XF.
- Connect load to terminals X2 and XF.

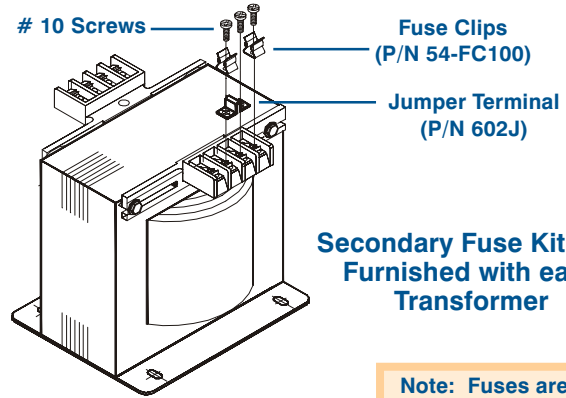

**Secondary Fuse Kit FKS  
Furnished with each  
Transformer**

**Note: Fuses are not  
supplied in fuse kit.**

## SERIES HC CONNECTION DIAGRAMS

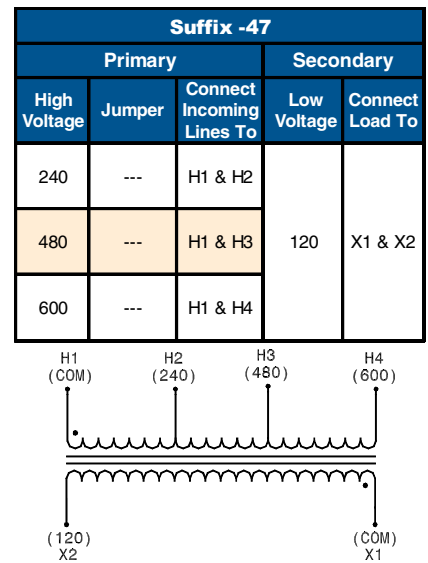
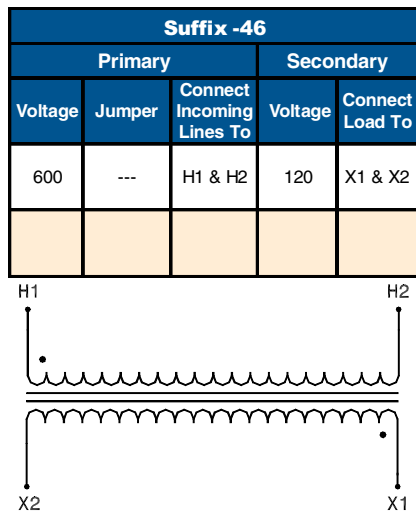
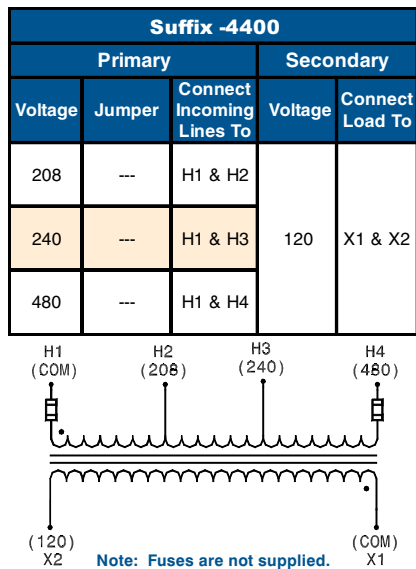
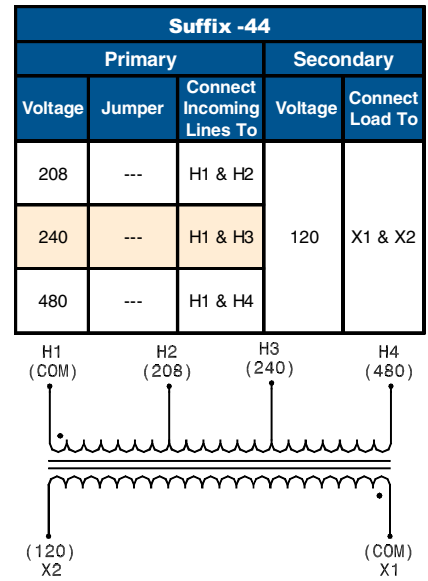
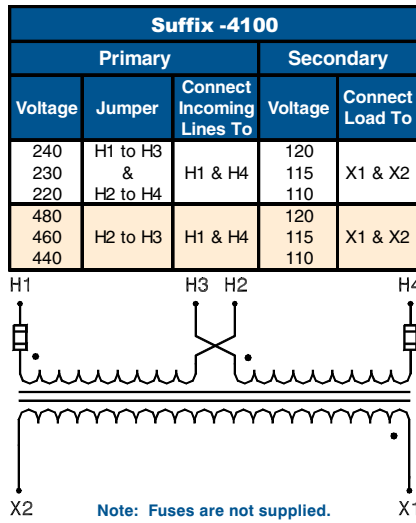
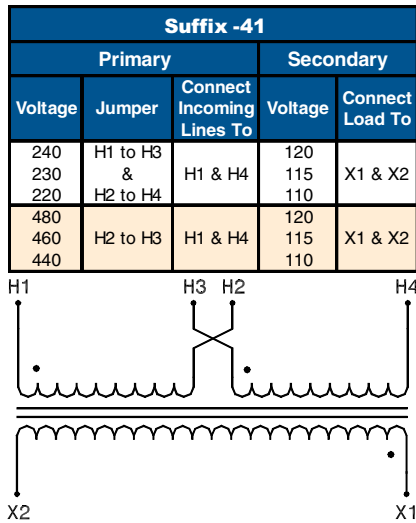

## Control Circuit Overcurrent Protection

Current North American Standards specify overcurrent protection on all control circuit transformers. These standards include the US *National Electric Code*®, UL 508, and the Canadian Electrical Code. Specified overcurrent protection may be accomplished by one of two options.

Primary Current (amps)	Overcurrent Protection Rating
Less than 2	300% maximum
2 to 9	167% maximum
9 or more	125% of rated primary current (or next higher standard rating)

Option 1: Provide primary overcurrent protection based on the parameters below.

Option 2: Provide both primary and secondary overcurrent protection. When this option is followed, the primary overcurrent device should be rated at no more than 250% of rated primary current and the secondary overcurrent device at no more than 125% of rated secondary current.

Option 2 is the preferred method of overcurrent protection, as it minimizes nuisance trips due to start-up inrush.

In either method, it is recommended that Class CC, time delay primary fuses be used in order to help prevent nuisance trips.

## SERIES 50 AND SERIES HC PRIMARY FUSE SIZE TABLE

Values listed in the table below are sized per option 1 above. Select the next higher fuse size if the fuse values shown do not correspond with standard fuse sizes.

Dongan recommends you refer to the current version of the *National Electrical Code*® and/or applicable local codes for further information on your specific application.

Fuse Size Table													
Primary Voltage													
kVA Cap.	120	208	230	240	277	380	416	440	460	480	550	575	600
.050	1.25	.8	.7	.7	.5	.4	.4	.3	.3	.3	.3	.3	.25
.075	1.8	1.0	1.0	1.0	.8	.6	.6	.5	.5	.4	.4	.4	.4
.100	2.5	1.5	1.25	1.25	1.0	.8	.8	.6	.6	.6	.6	.5	.5
.150	3.5	2.0	2.0	2.0	1.6	1.0	1.0	1.0	1.0	1.0	.8	.8	.8
.200	5.0	3.0	2.5	2.5	2.0	1.6	1.5	1.4	1.25	1.25	1.0	1.0	1.0
.250	3.5	3.5	3.2	3.2	2.5	2.0	1.8	1.6	1.6	1.5	1.25	1.25	1.25
.300	4.5	4.5	4.0	4.0	3.2	2.25	2.25	2.0	2.0	1.8	1.6	1.6	1.5
.375	5.6	5.6	5.0	4.5	4.0	3.0	2.8	2.5	2.5	2.25	2.0	2.0	1.8
.500	7.0	4.0	3.5	3.5	5.6	4.0	3.5	3.5	3.2	3.0	2.8	2.5	2.5
.750	12.0	6.0	5.5	5.0	4.5	5.0	5.6	5.0	5.0	4.5	4.0	3.5	4.0
1.0	15.0	8.0	7.5	7.0	6.0	4.5	4.0	4.0	3.5	3.5	5.0	5.0	5.0
1.5	17.5	12.0	12.0	12.0	9.0	6.25	6.0	5.6	5.0	5.0	4.5	4.0	4.0
2.0	25.0	15.0	15.0	15.0	12.0	9.0	8.0	7.5	7.0	7.0	6.0	6.0	6.0
3.0	30.0	20.0	17.5	17.5	15.0	15.0	12.0	12.0	12.0	10.0	9.0	9.0	8.0
5.0	---	30.0	30.0	30	25	20.0	20.0	15.0	15.0	15.0	12.0	15.0	15.0



# Series ES-10 CE Marked Industrial Control Transformers

DONGAN ELECTRIC MANUFACTURING CO. • 2987 FRANKLIN • DETROIT, MI 48207  
 800.428.2626 • 313.567.8500 • FAX 313.567.8828 • www.dongan.com

Series ES Industrial Control Transformers are designed to comply with Domestic, North American, and European Union electrical and testing standards. Series ES are UL and Canadian UL Listed by Underwriters Labs. In addition, Series ES are CE Marked, and licensed by the German testing agency TÜV Rheinland under License Number R 9679035.01.

Series ES transformers are the answer to your export needs. With the voltage combinations listed below, and built in approvals, the ES Series provides no-nonsense solutions for control and automation equipment destined for the European Community of nations.

The voltage combinations offered represent some of the most universally used. However, any combination of primary and secondary incorporating voltages of 600 volts and below is available on a short lead time, special order basis. In addition, capacities up to 25 kVA and special temperature rise configurations can be furnished. Please consult your distributor, Dongan Representative, or the factory for special ES Series transformer requirements.

## Features

- CE Marked
  - TÜV Rheinland Licensed, R 9679035.01
  - UL Listed, File E3210.
  - CSA Listed
- Agency Compliance
- 
- All copper windings.
  - IEC type finger safe terminals.
  - 200°C Insulation System.
  - 50/60 Hertz.
  - Class 1, general use, isolating transformer.
  - All Series ES are provided with an electrostatic shield (earth metal screen).
  - All Series ES are provided with a color coded protective earth (PE) terminal.
  - Consult factory for desired voltage combinations and kVA sizes not listed.

General Information											
Pri. Volts	380/400/416/440 460/480/575	380/416/480	380/400/416	220/380/400/416	Dimensions (inches)						Weight (lbs)
Sec. Volts	110/115/120	120/24 (24 Volts is limited to 20% of max. kVA)	110/220 115/230 120/240	95/115/120	A	B	C	Mounting			
kVA Cap.	Catalog Number	Catalog Number	Catalog Number	Catalog Number				D	E	F	
.150	ES-10100.326	ES-10100.366	ES-10100.376	ES-10100.386	4.00	4.50	5.00	2.75	3.75	.203 x .375	8
.250	ES-10130.326	ES-10130.366	ES-10130.376	ES-10130.386	5.25	4.50	6.00	3.25	3.75	.312 x .625	10
.375	ES-10150.326	ES-10150.366	ES-10150.376	ES-10150.386	6.00	4.50	6.00	4.50	3.75	.312 x .625	13
.500	ES-10170.326	ES-10170.366	ES-10170.376	ES-10170.386	5.25	5.25	6.50	3.25	4.38	.312 x .625	15
.750	ES-10190.326	ES-10190.366	ES-10190.376	ES-10190.386	6.00	6.38	7.50	4.00	5.31	.312 x .625	26
1.0	ES-10200.326	ES-10200.366	ES-10200.376	ES-10200.386	6.50	6.38	7.50	4.50	5.31	.312 x .625	30
1.5	ES-10210.326	ES-10210.366	ES-10210.376	ES-10210.386	6.00	7.50	8.50	4.00	6.00	.312 x .625	36
2.0	ES-10230.326	ES-10230.366	ES-10230.376	ES-10230.386	7.00	7.50	8.50	5.00	6.00	.312 x .625	50
3.0	ES-10250.326		ES-10250.376	ES-10250.386	8.00	7.50	8.50	6.00	6.00	.312 x .625	60
5.0	ES-10300.326		ES-10300.376	ES-10300.386	9.00	9.00	10.00	6.50	6.50	.312 x .625	90

### Series ES Single Phase and Three Phase Transformers

Please see Series ES - CE Marked Single Phase and Three Phase units in the appropriate sections of this catalog. A Certificate of Compliance is available by contacting your Dongan Representative or the factory Customer Service Department.

Dimensions & weights may change.  
Consult factory for certified drawings.

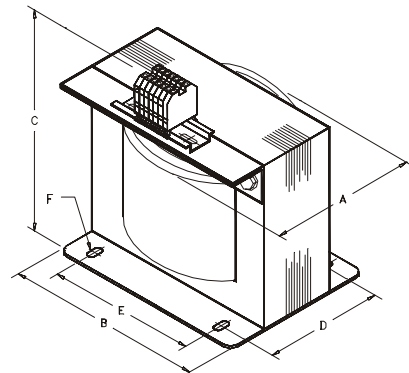



# Series ES-10 CE Marked Industrial Control Transformers

Suffix .326			
Primary Connections		Secondary Connections	
Pri. Voltage	Connect Incoming Lines To:	Sec. Voltage	Connect Load Lines To:
380	H1 & H3	110	X1 & X3
400	H1 & H3	115	X1 & X3
416	H1 & H4	115	X1 & X4
440	H1 & H4	120	X1 & X4
460	H1 & H4	115	X1 & X3
480	H1 & H4	120	X1 & X3
575	H1 & H5	120	X1 & X4

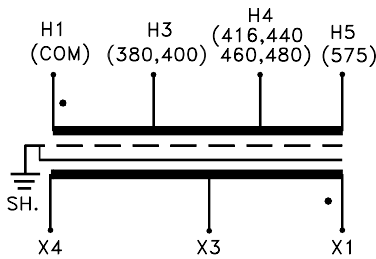

Suffix .366			
Primary Connections		Secondary Connections	
Pri. Voltage	Connect Incoming Lines To:	Sec. Voltage	Connect Load Lines To:
380	H1 & H3	24*	X1 & X3
416	H1 & H4	120	X1 & X4
480	H1 & H5		

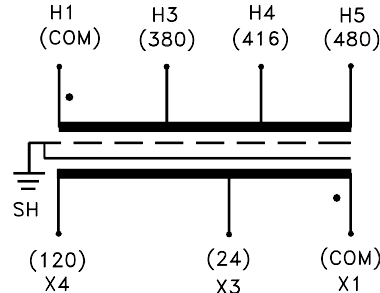

\*Maximum permissible load on 24 volt secondary is limited to 20% of the transformer's kVA. When 24 and 120 volts are used simultaneously, the total of both loads must not exceed the total transformer kVA.

Suffix .386			
Primary Connections		Secondary Connections	
Pri. Voltage	Connect Incoming Lines To:	Sec. Voltage	Connect Load Lines To:
220	H1 & H3	95	X1 & X3
380	H1 & H4	115	X1 & X4
400	H1 & H5	120	X1 & X5
416	H1 & H6		

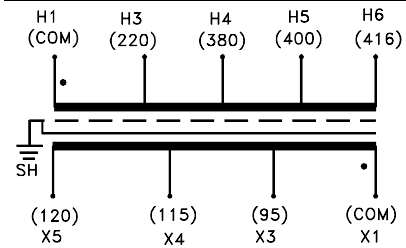

Suffix .376				
Primary Connections		Secondary Connections		
Pri. Voltage	Connect Incoming Lines To:	Sec. Voltage	Interconnect	Connect Load Lines To:
380	H1 & H2	110	X1 to X3 & X2 to X4	X1 & X4
400	H1 & H2	115		X1 & X4
416	H1 & H2	120		X1 & X4
380	H1 & H2	220	X2 to X3	X1 & X4
400	H1 & H2	230		X1 & X4
416	H1 & H2	240		X1 & X4
416	H1 & H2	120/240	X2 to X3	X1 & X2/X3 & X4

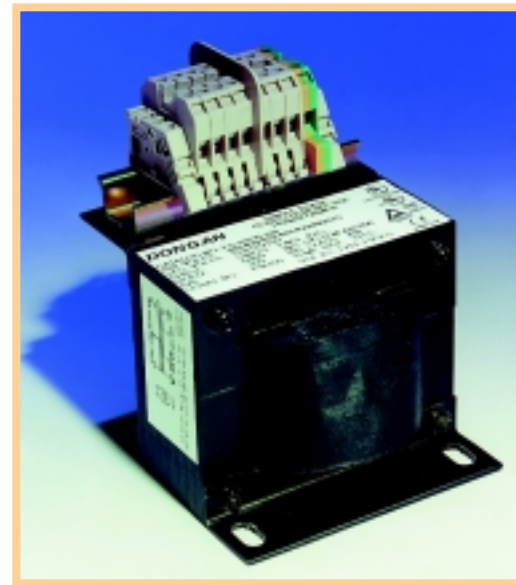
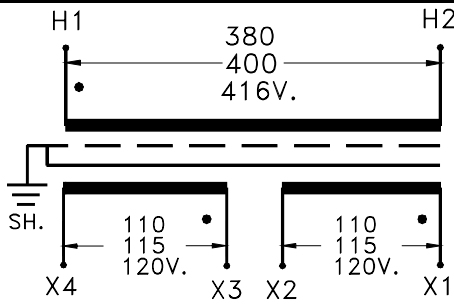

Series ES - 10

Agency Compliance



DONGAN ELECTRIC MANUFACTURING CO. • 2987 FRANKLIN • DETROIT, MI 48207  
 800.428.2626 • 313.567.8500 • FAX 313.567.8828 • www.dongan.com

## AP12 - Encapsulated Industrial Control Transformers

DONGAN ELECTRIC MANUFACTURING CO. • 2987 FRANKLIN • DETROIT, MI 48207  
 800.428.2626 • 313.567.8500 • FAX 313.567.8828 • www.dongan.com

Series AP12 Industrial Control Transformers are designed to comply with industrial and automotive specifications that require the control transformer to be mounted in a separate enclosure, remote from the main control panel. Series AP12 control transformers eliminate the need to purchase a separate enclosure, as these units are encapsulated within a NEMA 12 enclosure suitable for remote mounting.

External or remote mounting of the Series AP12 conserves critical panel mounting space and reduces internal control cabinet temperatures, which can be critical to the reliable operation of many solid state, logic, and thermal control devices.

### Features

- **UL Listed, File E3210.**
- **CUL Listed, File E3210.**
- **All copper windings.**
- **NEMA 12 enclosure** and encapsulated core and coil construction.
- **180°C Insulation System and 55°C Temperature Rise** for long service in high ambient environments.
- **50/60 Hertz.**
- **Capacity range from 1 kVA to 10 kVA.**
- Available primary voltages include 208, 240, and 380, 480, 575, 600. Secondary voltage is 120 volts.
- Primary and secondary leads are equipped with ring terminals for convenient connections.
- **Regulation characteristics** equal or exceed the highest industry standards.
- **Electrostatic shield** available as an extra cost option.
- Consult factory for desired voltage combinations and kVA sizes not listed.

General Information											
Pri. Volts	240 X 480	380 / 575	208	600	Dimensions (inches)						Weight (lbs)
	230 X 460			575							
Sec. Volts	120	120	120	120	Height A	Width B	Depth C	Depth D	Mounting		Weight (lbs)
	115			115					E	F	
110	110			110							
kVA Cap.	Catalog Number	Catalog Number	Catalog Number	Catalog Number	Height A	Width B	Depth C	Depth D	Mounting		Weight (lbs)
1.0	AP12-351	AP12-352	AP12-353	AP12-354	10.50	10.00	6.62	6.12	4.00	8.50	50
1.5	AP12-401	AP12-402	AP12-403	AP12-404	12.00	10.81	7.19	6.69	6.00	9.13	68
2.0	AP12-451	AP12-452	AP12-453	AP12-454	14.00	14.00	9.25	8.75	8.00	12.00	97
3.0	AP12-501	AP12-502	AP12-503	AP12-504	14.00	14.00	9.25	8.75	8.00	12.00	120
5.0	AP12-551	AP12-552	AP12-553	AP12-554	14.00	14.38	10.00	9.50	8.00	12.38	149
7.5	AP12-601	AP12-602	AP12-603	AP12-604	15.00	18.00	12.50	12.00	8.00	16.00	198
10.0	AP12-651	AP12-652	AP12-653	AP12-654	15.00	18.00	12.50	12.00	8.00	16.00	225

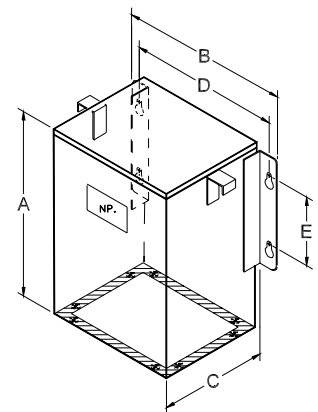
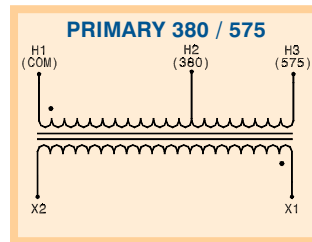
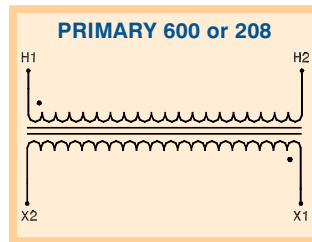
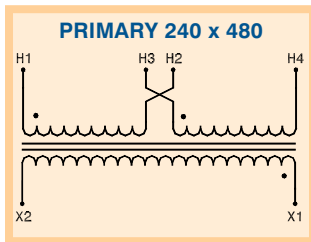

Dimensions & weights may change. Consult factory for certified drawings.

**Series AP12**  
Wall Mount - Encapsulated - NEMA 12

# Series FP12-Encapsulated Industrial Control Transformers

Series FP12 Industrial Control Transformers are similar to the AP12 Series with two important differences. The FP12 Series is 115°C rise (versus 55°C) and they are manufactured with an electrostatic shield between primary and secondary.

They are designed to comply with industrial and automotive specifications that require the control transformer to be mounted in a separate enclosure, remote from the main control panel.

External or remote mounting of the Series FP12 conserves critical panel mounting space and reduces internal control cabinet temperatures, which can be critical to the reliable operation of many solid state, logic, and thermal control devices.

## Features

- **UL Listed, File E3210.**
- **CUL Listed, File E3210.**
- **All copper windings.**
- **NEMA 12 enclosure** and encapsulated core and coil construction.
- **180°C Insulation System and 115°C Temperature Rise** for long service in high ambient environments.
- **Electrostatic Shield.**
- **60 Hz except 380/575-120 which is 50/60 Hz.**
- **50/60 Hz unit weights are approximately 20% higher than those shown.**
- **Primary and secondary leads** are equipped with ring terminals for convenient connections.
- **Regulation characteristics** equal or exceed the highest industry standards.
- Consult factory for desired voltage combinations and kVA sizes not listed.

General Information										
Pri. Volts	240 X 480	380 / 575	208	600	Dimensions (inches)					Weight (lbs)
	230 X 460			575						
Sec. Volts	120	120	120	120	Height A	Width B	Depth C	Mounting		
	115			110				D	E	
kVA Cap.	Catalog Number	Catalog Number	Catalog Number	Catalog Number						
1.0	FP12-351	FP12-352	FP12-353	FP12-354	10.50	10.00	6.62	6.12	4.00	29
1.5	FP12-401	FP12-402	FP12-403	FP12-404	10.50	10.00	6.62	6.12	4.00	38
2.0	FP12-451	FP12-452	FP12-453	FP12-454	12.00	10.81	7.19	6.69	6.00	45
3.0	FP12-501	FP12-502	FP12-503	FP12-504	12.00	10.81	7.19	6.69	6.00	78
5.0	FP12-551	FP12-552	FP12-553	FP12-554	14.00	14.00	9.25	8.75	8.00	97
7.5	FP12-601	FP12-602	FP12-603	FP12-604	14.00	14.38	10.00	9.50	8.00	151
10.0	FP12-651	FP12-652	FP12-653	FP12-654	14.00	14.38	10.00	9.50	8.00	164

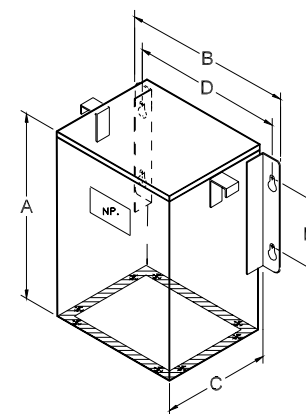
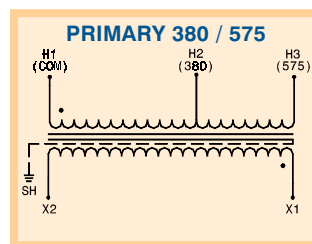
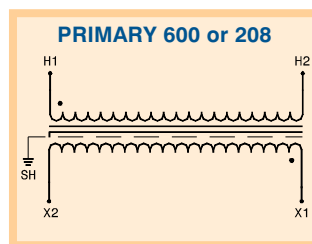
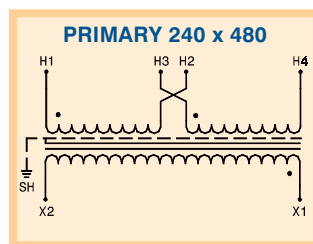

Series FP12

Wall Mount - Encapsulated - NEMA 12

Dimensions & weights may change. Consult factory for certified drawings.

DONGAN ELECTRIC MANUFACTURING CO. • 2987 FRANKLIN • DETROIT, MI 48207  
 800.428.2626 • 313.567.8500 • FAX 313.567.8828 • www.dongan.com

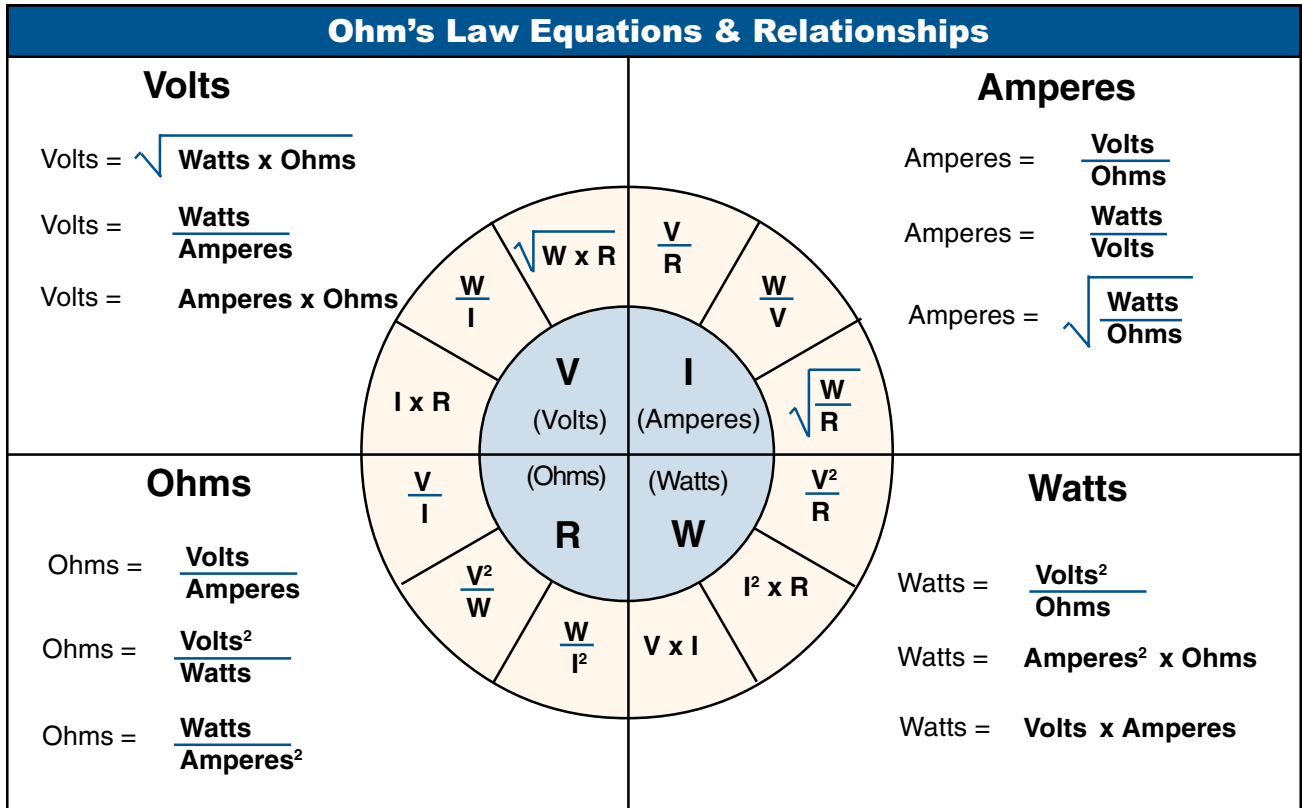

Ohm's Law Formulas			
To Find	Single Phase	Three Phase 3 or 4 Wire (Phase to Phase)	Three Phase 4 Wire Wye (Phase to Neutral)
Amperes when kVA is known:	$\frac{\text{kVA} \times 1000}{V}$	$\frac{\text{kVA} \times 1000}{V \times 1.73}$	$\frac{\text{kVA} \times 1000}{V \times 3}$
Amperes when Horsepower is known:	$\frac{\text{HP} \times 746}{V \times \% \text{Eff.} \times \text{PF}}$	$\frac{\text{HP} \times 746}{V \times 1.73 \% \text{Eff.} \times \text{PF}}$	$\frac{\text{HP} \times 746}{V \times 3 \times \% \text{Eff.} \times \text{PF}}$
Amperes when Kilowatts are known:	$\frac{\text{kW} \times 1000}{V \times \text{PF}}$	$\frac{\text{kW} \times 1000}{V \times 1.73 \times \text{PF}}$	$\frac{\text{kW} \times 1000}{V \times 3 \times \text{PF}}$
Kilowatts:	$\frac{I \times V \times \text{PF}}{1000}$	$\frac{I \times V \times 1.73 \times \text{PF}}{1000}$	$\frac{I \times V \times 3 \times \text{PF}}{1000}$
Kilovolt Amperes: ( kVA )	$\frac{I \times V}{1000}$	$\frac{I \times V \times 1.73}{1000}$	$\frac{I \times V \times 3}{1000}$
Horsepower:	$\frac{I \times V \times \% \text{Eff.} \times \text{PF}}{746}$	$\frac{I \times V \times 1.73 \times \% \text{Eff.} \times \text{PF}}{746}$	$\frac{I \times V \times 3 \times \% \text{Eff.} \times \text{PF}}{746}$
Watts:	$V \times I \times \text{PF}$	$V \times I \times 1.73 \times \text{PF}$	$V \times I \times 3 \times \text{PF}$
Power Factor:	$\frac{\text{kW}}{\text{kVA}}$	$\frac{\text{kW}}{\text{kVA}}$	$\frac{\text{kW}}{\text{kVA}}$

I = Amperes  
V = Volts  
kW = Kilowatts

HP = Horsepower  
%Eff. = Percent Efficiency  
PF = Power Factor

kVA = Kilovoltamperes

General Heating Formula

Temperature Conversion Formulas

$$\text{KW} = \frac{\text{Wt. of material (lbs.)} \times \text{specific heat} \times \text{temp rise } ^\circ\text{F}}{3412 \times \text{heat-up time (hours)}}$$

$$^{\circ}\text{C} = \frac{5}{9} ( ^{\circ}\text{F} - 32 )$$

$$^{\circ}\text{F} = \frac{9}{5} ( ^{\circ}\text{C} + 32 )$$

# Miscellaneous Transformers



## Contents

Series SDA, Servo-Drive Isolation Allen Bradley Type 1388 .....	88
Industrial Ignition Transformers .....	90

DONGAN ELECTRIC MANUFACTURING Co. • 2987 FRANKLIN • DETROIT, MI 48207  
800.428.2626 • 313.567.8500 • Fax 313.567.8828 • [www.dongan.com](http://www.dongan.com)





# Series SDA, Servo-Drive Isolation Allen Bradley Type 1388

DONGAN ELECTRIC MANUFACTURING CO. • 2987 FRANKLIN • DETROIT, MI 48207  
 800.428.2626 • 313.567.8500 • FAX 313.567.8828 • www.dongan.com

Series SDA Servo Drive Isolation transformers are designed and manufactured for use with Allen-Bradley Type 1388 AC servo-drive motor controllers. Series SDA units are electrically, mechanically, and dimensionally interchangeable with transformers offered as original equipment.

Servo-Drive transformers are also manufactured to other manufacturers' specifications. Please consult your distributor, Dongan Representative, or the factory with your specifications to arrange a quotation.

## Features

- **UL Listed, File E78234.**
- **CSA Certified, File LR 560.**
- **All copper windings.**
- **Core and coil construction.**
- **200°C Insulation System** and 115°C Temperature Rise.
- **All primary and secondary** connections are made on a barrier block style terminal board.
- **Electrostatic Shield** between primary and secondary.
- **Terminal board is protected with a polycarbonate shield to prevent damage.**
- **Regulation** of less than 3%, as defined by NEMA ST20.
- Consult factory for additional servo-drive combinations available from other manufacturers.

General Information												
kVA Cap.	Catalog Number	Allen Bradley Catalog Number	Primary Voltage	Hertz	Wiring Diag.	A	B	C	D	E	F	Weight (lbs)
1.25	<b>SDA-141012A</b>	1388-T012DR	240/480	60	A	9.00	10.00	13.00	5.00	3.06	.438 x .750	26
	<b>SDA-241012A</b>	1388-T012ER	240/380/415/480	50/60	B	9.00	12.00	13.00	6.50	3.63	.438 x .750	37
	<b>SDA-341012A</b>	1388-T012FR	200/220/240/480	50/60	B	9.00	12.00	13.00	6.50	3.63	.438 x .750	37
2.5	<b>SDA-141025A</b>	1388-T025DR	240/480	60	A	11.00	11.00	14.00	6.50	3.29	.438 x .750	43
	<b>SDA-241025A</b>	1388-T025ER	240/380/415/480	50/60	B	11.00	11.00	14.00	6.50	4.50	.438 x .750	60
	<b>SDA-341025A</b>	1388-T025FR	200/220/240/480	50/60	B	11.00	11.00	14.00	6.50	4.50	.438 x .750	60
5.0	<b>SDA-141050A</b>	1388-T050DR	240/480	60	A	11.00	11.00	14.00	6.50	5.25	.438 x .750	77
	<b>SDA-241050A</b>	1388-T050ER	240/380/415/480	50/60	B	11.00	11.00	14.00	6.50	6.75	.438 x .750	100
	<b>SDA-341050A</b>	1388-T050FR	200/220/240/480	50/60	B	11.00	11.00	14.00	6.50	6.75	.438 x .750	100
7.5	<b>SDA-141075A</b>	1388-T075DR	240/480	60	A	12.00	12.50	16.00	8.00	5.69	.438 x .750	94
	<b>SDA-241075A</b>	1388-T075ER	240/380/415/480	50/60	B	12.00	15.00	16.00	7.90	5.30	.438 x .750	118
	<b>SDA-341075A</b>	1388-T075FR	200/220/240/480	50/60	B	12.00	15.00	16.00	7.90	5.30	.438 x .750	118
10.0	<b>SDA-141100A</b>	1388-T100DR	240/480	60	A	12.00	12.50	16.00	8.00	5.84	.438 x .750	114
	<b>SDA-241100A</b>	1388-T100ER	240/380/415/480	50/60	B	12.00	15.00	16.00	7.90	5.90	.438 x .750	134
	<b>SDA-341100A</b>	1388-T100FR	200/220/240/480	50/60	B	12.00	15.00	16.00	7.90	5.90	.438 x .750	134

## SERIES SDA OUTLINE DRAWING

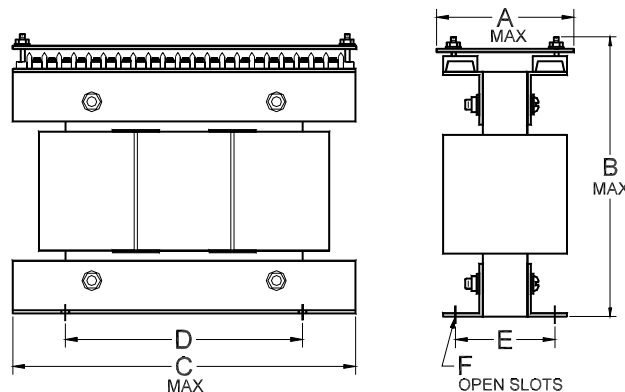

**Series SDA, Servo-Drive Isolation  
Allen Bradley Type 1388**

**SERIES SDA**

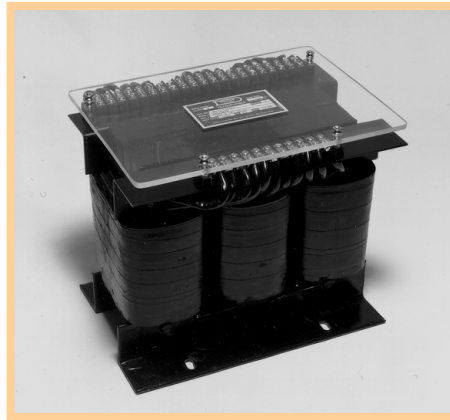

**SERIES SDA CONNECTION DIAGRAM A**

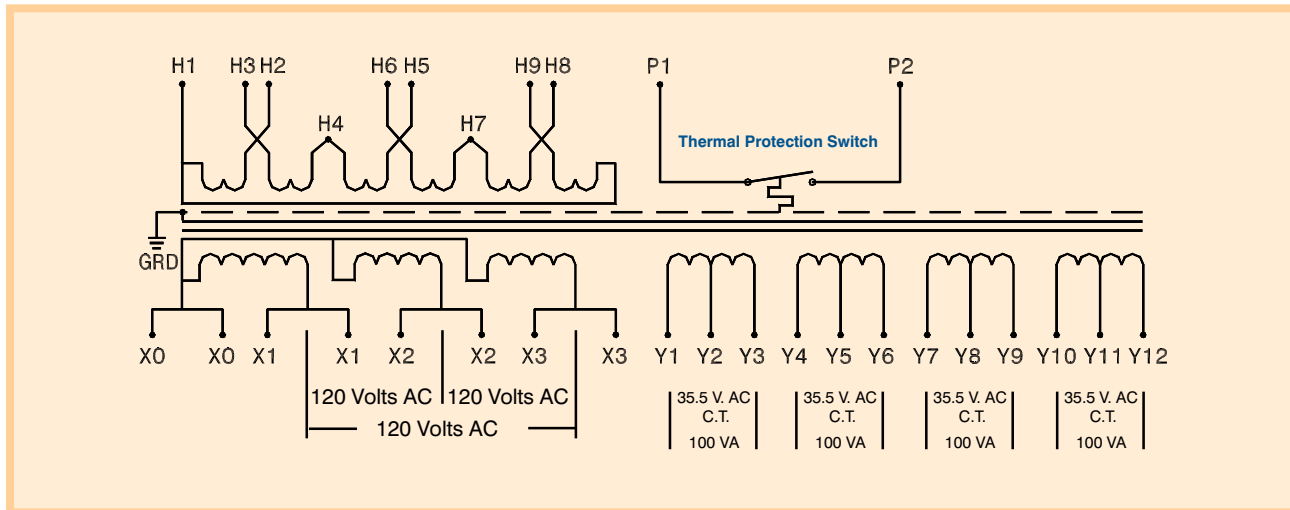

**SERIES SDA CONNECTION DIAGRAM B**

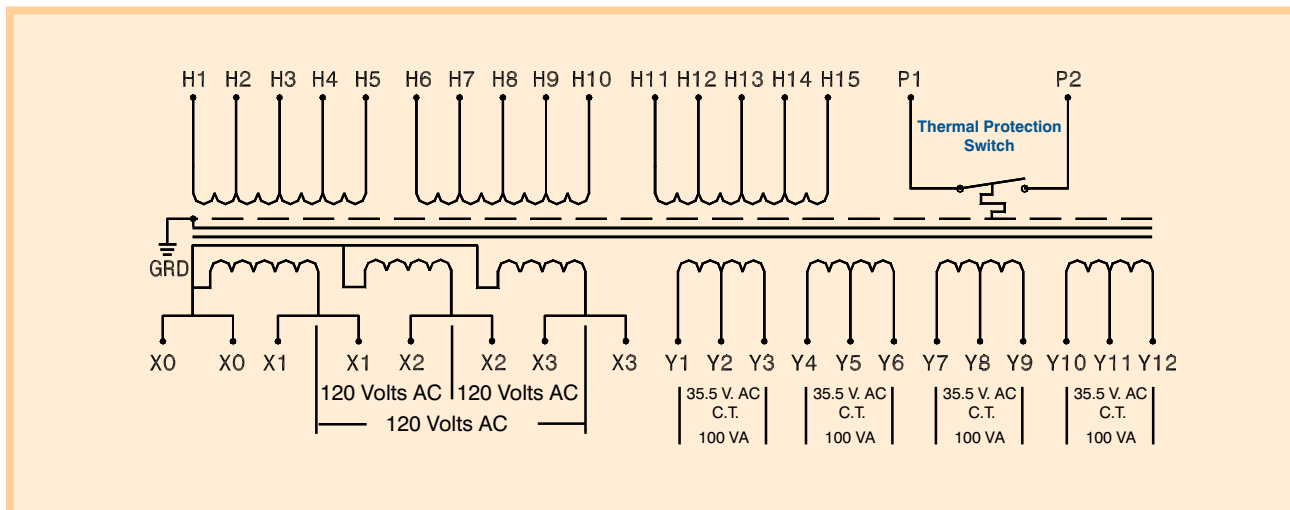

DONGAN ELECTRIC MANUFACTURING CO. • 2987 FRANKLIN • DETROIT, MI 48207  
800.428.2626 • 313.567.8500 • FAX 313.567.8828 • www.dongan.com

## Industrial Ignition Transformers

Dongan Industrial Ignition transformers are used in a wide variety of commercial and industrial heating applications. Their uses include commercial heat treating installations, bakeries, grain dryers, and industrial ovens.

Primary voltages include 110, 120, 208, 220, 240, and 480. Secondary voltages include 5,000, 6,000, 7,500, 8,500, and 10,000. The 10,000 volt models come in either an end

grounded 10,000 volt configuration or a twin 5,000 volt version.

Epoxy filled variations complete the line, providing solutions for higher ambient temperature applications. Additionally, a liquid filled model, the LFI Series is available for the harsh conditions found with ozone generation installations. LFI Series literature may be ordered by requesting Transfax 111.

DONGAN ELECTRIC MANUFACTURING CO. • 2987 FRANKLIN • DETROIT, MI 48207  
800.428.2626 • 313.567.8500 • FAX 313.567.8828 • www.dongan.com

### INDUSTRIAL OIL AND GAS IGNITION

UL Listed File E12339. CSA Certified LR560.

<p>A05-SA6 120 V Pri 60 Hz EO5-SA6 110 V Pri 50 Hz 5000 V Sec. 20 ma 115 va</p> 	<p>A05-SC7 120 V Pri 60 Hz Sec. 5000 V 20 ma 115 va</p> 	<p>A06-SA6 120 V Pri 60 Hz C06-SA6 240 V Pri 60 Hz F06-SA6 220 V Pri 50 Hz Sec. 6000 V 20 ma 175 va</p> 	<p>A06-SA6X 120 V Pri 60 Hz Sec. 6000 V 20 ma 175 va</p>  <p>epoxy filled</p>
<p>A06-SD7 120 Pri 60 Hz 6000 V Sec. 20 ma 175 va</p> 	<p>A06-SA21 120 V Pri 60 Hz Sec. 6000 V 20 ma 175 va</p> 	<p>A08-SA1 120 V Pri 60 Hz Sec. 8500 V 20 ma 230 va</p> 	<p>A10-LA2 120 V Pri 60 Hz C10-LA2 240 V Pri 60 Hz Sec. 10,000 V 22 ma 250 va</p> 
<p>A10-LF3 120 V Pri 60 Hz C10-LF3 240 V Pri 60 Hz N10-LF3 480 V Pri 60 Hz Sec. 10,000 or 2X5000 V 22 ma 250 va</p> 	<p>A10-LF3X 120 V Pri 60 Hz Sec. 10,000 or 2X5000 22 ma 250 va</p>  <p>epoxy filled</p>	<p>A10-LA22 120 V Pri 60 Hz Sec. 10,000 22 ma 250 va</p> 	<p>A10-LA2X 120 V Pri 60 Hz Sec. 10,000 22 ma 250 va</p>  <p>epoxy filled</p>
<p>A15-LA61 120 V Pri 60 Hz Sec. 2X7500 30 ma 560 va</p> 	<p>A15-LA6 120 V Pri 60 Hz Sec. 3X5000 22 ma 375 va</p> 	<p>A20-LA7 120 V Pri 60 Hz Sec. 4X5000 22 ma 500 va</p> 	<p>A10-LN2X Pri 120 V 60 Hz Sec. 10,000 22 ma 250 va</p>  <p>epoxy filled</p>

## Transformer Terms and Definitions

A transformer is a static electrical apparatus, without moving parts, which transfers energy from one alternating current source to one or more circuits - at the same frequency (Hz). Transformers may be used to increase voltage (Step-Up), decrease voltage (Step-Down) or to keep voltage the same in electrically isolated circuits. This ability creates an effective match between the incoming line voltage and the required load voltage for a wide variety of devices in a wide variety of electrical circuits. Transformers are designed to provide a long life when used under normal conditions of load, temperature and line harmonic content. Transformers operate under the principles of electromagnetic induction.

### **Dry-Type Transformers:**

Transformers are divided into two basic types, dry-type and oil-filled. Dry-type transformers rely on various types of solid insulation materials, both natural (paper-based and various varnishes) and synthetic (various polymers and silicones), and pass their heat directly to air or indirectly through a heat conducting encapsulant such as epoxy.

Dry-type transformers require little or no maintenance through their service life other than assuring that connections remain clean and tight, that the loading on the transformer remains within design limits, and that air flow through the transformer is not impeded by extraneous materials or dust. Dry-type transformers are therefore the primary choice for indoor locations, and can be used anywhere a transformer is required.

Oil-filled transformers, on the other hand, have a sealed or pressure-vented enclosure with the windings submersed in an oil-based fluid which serves as both insulation and a heat transfer (cooling) medium. Because the oil may pose a fire hazard, oil-filled transformers are generally limited to outdoor use. The oil and its attendant cooling devices (pumps, fans, radiators, etc.) also require regular maintenance and supervision.

Except for the very smallest sizes, all Dongan dry-type enclosed transformers are fully approved for indoor or outdoor installation under normal conditions without any accessory purchase or modification (NEMA 3R rating). Some specialized types are supplied standard in NEMA 12 enclosures. Enclosures for more severe locations, such as NEMA 4, 4X, and 12 are available on a special order basis.

### **Construction:**

Transformers, in their simplest form, consist of two or more windings of insulated magnet wire wound around insulated forms. These forms are then

placed into an iron core consisting of thin steel plates laminated and fastened together into a single unit. Alternating current supplied to the line, or input side of the transformer creates a magnetic field which induces a voltage in the load, or output side of the transformer. This current flows even though the two windings do not physically touch each other. The change of voltage from line side to load side is proportional to the turns ratio of the two windings. This turns ratio forms the basis for the various transformer voltage combinations depicted in this catalog.

Unless noted, transformers in this catalog are wound as *isolation* or *insulating* type transformers. This means that primary and secondary windings are physically separated, and electrically isolated, from each other. This physical separation of windings makes isolation transformers distinct from *autotransformers* - whose windings are physically connected to each other. Most installations of general purpose transformers require the use of an insulating or isolating type transformer. Buck-boost applications are a noted exception.

### **Taps:**

Installers of transformers in commercial and industrial locations frequently encounter inherent high or low voltage conditions in which the use of a transformer would result in proportionally higher or lower voltage on the output side of the transformer. This results because most transformers are designed with fixed turns ratios. Transformer taps are designed to compensate for these steady state, high or low voltage situations while still allowing the transformer to deliver full nameplate rated output current and voltage to the connected load. Taps are referred to as FCAN - *Full Capacity Above Normal* and FCBN - *Full Capacity Below Normal* and are generally furnished on the primary winding. By connecting to an above or below normal tap, the transformer's turns ratio is changed.

For example, suppose line voltage in a 480 volt to 120 volt step down installation is supposed to be 480 volts, but is measured and found to be only 432 volts (a 48 volt -10% difference). Connecting a transformer without taps would result in an output of about 10% reduced voltage, or 108 volts. While this may be acceptable for some installations, other equipment may not tolerate the low voltage. However, the same load connected to a transformer with its primary wired to a 10% below normal tap will see output of exactly 120 volts, as desired.





# Transformer Terms and Definitions

DONGAN ELECTRIC MANUFACTURING CO. • 2987 FRANKLIN • DETROIT, MI 48207  
800.428.2626 • 313.567.8500 • FAX 313.567.8828 • www.dongan.com

### **Polarity:**

Polarity is the instantaneous voltage obtained from the secondary winding in relation to the primary winding.

While Alternating Current (AC) does not have polarity in the same sense as Direct Current (DC), polarity is involved whenever circuits or transformers are connected together. When two wires in AC circuits are of like polarity, the voltage is rising simultaneously in both, with the current flow in the same direction.

Polarity is normally only a consideration when connecting two or more transformers or windings in series or parallel. For example, the voltages of two windings connected in series will add together if the start of the second winding is connected to the finish of the first; if the finishes or starts are connected together, the lower voltage will subtract from the higher. This is the principle upon which Buck-Boost transformers and transformers with split primaries or secondaries operate.

### **Shielding:**

Most transformer installations today are used to power circuits containing solid state devices sensitive to electrical "noise", transients and voltage spikes. While the possibility of voltage spikes due to lighting strikes on nearby transmission lines exists, the more frequent threat to electronic equipment comes from conducted electrical noise. Noise and transients can enter installations from distant external sources or from internal sources such as fluorescent ballasts and switch mode power supplies. Shielded transformers mitigate the harmful effects of certain types of transients.

Transients are high energy, short duration bursts of electrical energy covering a wide range of frequencies other than the nominal domestic 60 Hz distribution frequency. These bursts range from a high of 20 kHz to a low or about 25 Hz. Distribution systems encounter two types of transient noise: transverse mode and common mode noise. Differences in the two are found in their reference to ground.

Transverse mode noise is noise occurring between circuit supply lines. Shielded isolation transformers have no significant effect in combating transverse noise. Generally, though, transverse mode noise transients dissipate when loads are placed across the lines on which they appear.

Common mode noise, on the other hand, contains transients appearing between the wires of the distribution system and ground. Common mode noise is typically passed to the secondary, or output side of the transformer through a capacitive link between the primary and secondary windings. Circuits containing substantial common mode noise will eventually cause failure to sensitive components.

Shielded isolation transformers attenuate common mode noise transients by providing a barrier, called a Faraday Shield, to the capacitive linking of the primary and secondary windings. The barrier reduces, or attenuates, the amount of non 60 Hz frequencies passed through the transformer in either direction. This is accomplished by connecting the Faraday Shield to ground, effectively reducing transmission of frequencies other than 60 Hz.

Typical attenuation levels of 50:1 ( 34 DB ) are achievable with Dongan shielded isolation transformers. This attenuation provides noise levels generally considered to solve many noise and transient caused problems. Most Dongan General Purpose transformers are furnished with shields at no additional cost. Shielded transformers are designated by the suffix SH or the prefix ES.

### **Regulation:**

A transformer will generally provide a higher output voltage when no load is attached to it than when the transformer is fully loaded at nameplate capacity. Stated differently, under load, a transformer's output voltage drops slightly. Regulation is the ratio of the difference between a transformer's no load output voltage to its full load output voltage expressed as a percentage.

For example, suppose a transformer has a no load voltage of 124 volts and a full load voltage of 120 volts. The transformer's regulation is calculated as follows:

$$\text{Regulation} = \frac{(\text{No Load Voltage} - \text{Full Load Voltage})}{(\text{No Load Voltage})}$$

$$\text{Regulation} = \frac{124 - 120}{120}$$

$$\text{Regulation} = 3.33\%$$

## Temperature and Insulation

### **Ambient Temperature:**

The ambient temperature is the average temperature of the air in the immediate area surrounding the transformer. The transformer dissipates its heat into this ambient air.

All Dongan transformers are designed to operate in ambient temperatures of 40°C (104°F) maximum. Derating of transformers is necessary when ambients exceed 40°C (See Operations Section)

### **Temperature Rise:**

Temperature rise refers to the difference in temperature between the ambient air temperature and the actual temperature of the windings or enclosure.



# Transformer Terms and Definitions

## Insulation System:

An insulation system is a collection of insulating components used to protect the transformer from the effects of heat and dielectric stress occurring during the normal operation of the transformer. Typically these components include insulation coatings on magnet wire, insulation between winding layers and between windings, tape, and other components.

## Hot-Spot Temperature:

The hot-spot temperature refers to the highest temperature found inside the transformer winding. Hot-spot temperature allowances vary with insulation classes. See the Total Winding Temperature, Chart 1.1, for a graphical representation of hot spot temperature values.

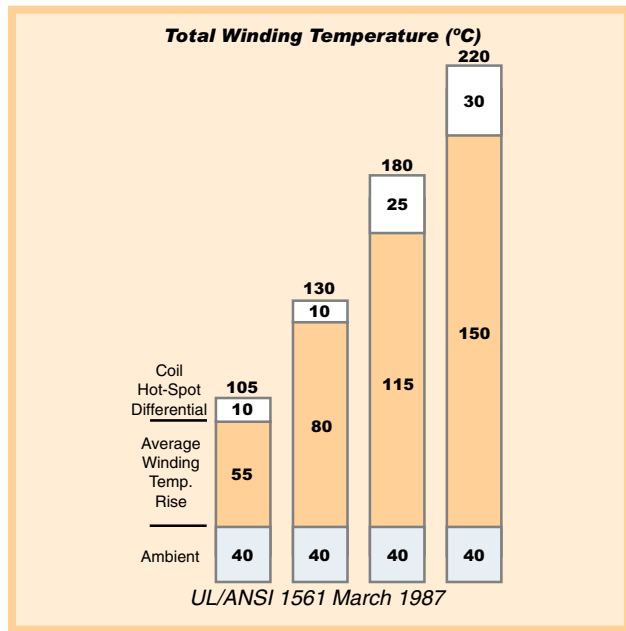

Chart 1.1

## Insulation System Temperature and Class:

The insulation system temperature indicates the insulation system's maximum operating temperature in service. This temperature is determined by the temperature rating of the insulation components in a particular design including tape, layer insulation, magnet wire insulation coatings and impregnation materials. The system temperature is determined by adding the ambient temperature, rise and the hot spot temperature. Transformers operated under normal operating conditions will not exceed this temperature, and will enjoy a long service life.

Dongan transformers use UL approved insulation systems whose constituent parts have been extensively tested for compatibility and long life.

## Insulation Class:

This is an older letter classification reference to an insulation material's ability to protect a transformer operating at different temperature rises and various total operating temperatures. The original letter designations have given way to numerical Centigrade insulation system temperatures, the most popular of which are 105°C, 130°C, 180°C, 200°C, and 220°C. Please see Chart 1.2 to see how these classes and temperature ratings are derived.

Former Designation	Limiting Temperature	Average Temperature Rise
Class A	105° C	55° C
Class B	130° C	60° C
Class F	155° C	85° C
Class H	180° C	115° C
Class N	200° C	135° C
Class R	220° C	150° C
Class C	240° C	150° C

Chart 1.2

A transformer operating within its insulation system will have the same life expectancy as any other insulation system. In other words, a high temperature rise system is designed for the same service life as the low temperature rise system.

## Basic Impulse Level (BIL) and Transformer Insulation Systems:

Basic Impulse Level (BIL) refers to a series of dielectric tests performed on the transformer's insulation system. These tests measure the insulation system's ability to withstand line surges from such sources as the network grid and lightning.

These tests are performed by applying a high frequency voltage between windings and between windings and ground to look for weaknesses in the insulation system.

Dongan transformers comply with NEMA standard 10 kV BIL ratings.

## Enclosure Temperatures:

The temperature of the enclosure of enclosed transformers is not equivalent to the temperature of the transformer inside. In air-cooled transformers, much of the heat produced by the transformer is transferred to the air flowing through the cabinet. This allows the enclosure surface to be much cooler than the transformer element inside.



# Transformer Terms and Definitions

DONGAN ELECTRIC MANUFACTURING CO. • 2987 FRANKLIN • DETROIT, MI 48207  
 800.428.2626 • 313.567.8500 • FAX 313.567.8828 • www.dongan.com

In epoxy encapsulated transformers, the transformer's heat is conducted by the epoxy to the enclosure. Because the surface area of the enclosure is greater than that of the transformer, the temperature at the enclosure surface tends to be significantly less than that found on the surface of the transformer element inside.

UL and CSA standards strictly regulate the highest temperature which the case can reach. The enclosure temperature rise shall not exceed 50°C in a 40°C ambient at full rated current. While these temperatures are quite warm to the touch, they are completely within the allowed parameters of the insulation system, UL and NEMA standards. All Dongan transformers comply with these standards.

### Enclosure Ratings:

NEMA and NEC® standards provide enclosure ratings which classify the degree of protection afforded by enclosures against various environmental conditions. The chart to the right indicates some of the most common ratings and their protection characteristics.

### Excitation Current, Losses and Efficiency:

Excitation current in transformers is the amount of current needed to magnetize and maintain the field in the transformer's core whether a secondary load is connected or not. Excitation current is normally expressed as a percentage of the full rated current of the winding in which it is measured and is frequently referred to as "no load current", although this term is not technically correct.

Typical excitation current values range from about 10% in small, fractional kVA transformers to lows of 1% or 2% in larger dry-type transformers.

Excitation current has two components: a magnetizing component and a core loss component. Core losses are comprised of eddy current and hysteresis losses and are observed as dissipated heat. These losses (and heat) are constant whether the load is connected or not.

Under load conditions, energy is also consumed in the windings due to the winding's resistance. These losses, converted to heat, are called winding losses and are proportional to the amount of load. The sum of core losses and winding losses constitute the total losses developed by a transformer.

Transformer efficiency is a reflection of the amount of total losses inherent in the transformer. It is calculated as follows:

$$\% \text{ Efficiency} = \frac{\text{Nameplate kVA}}{\text{Nameplate kVA} + \text{Total Losses}} \times 100$$

In a typical enclosed, ventilated, dry-type transformer, air flow through and around the enclosure transfers and dissipates the heat from the core and windings. This assures that enclosure temperatures will remain well below internal winding temperatures.

### Inrush Current:

All transformers consume a higher amount of amps than rated current for a very short duration when first energized. This "inrush current" is highest when

Enclosure Rating	Provides a Degree of Protection Against:	May be Used
<b>NEMA 1</b>	Incidental contact and falling dirt.	Indoor
<b>NEMA 2</b>	Limited amounts of falling water and dirt.	Indoor
<b>NEMA 3</b>	Rain, sleet, and windblown dust, and ice resistant.	Outdoor
<b>NEMA 3R</b>	Rain, sleet, and ice resistant.	Outdoor
<b>NEMA 4</b>	Windblown dust and rain, splashing or hose directed water and ice resistant.	Indoor / Outdoor
<b>NEMA 4X</b>	Same as NEMA 4 plus corrosion resistant	Indoor / Outdoor
<b>NEMA 6</b>	Entry of water during temporary, limited submersion and damage from external ice.	Indoor / Outdoor
<b>NEMA 6P</b>	Entry of water during prolonged, submersion at a limited depth and damage from external ice.	Indoor / Outdoor
<b>NEMA 11</b>	Oil immersion, corrosion resistance.	Indoor
<b>NEMA 12</b>	Circulating dust, falling dirt, and dripping noncorrosive liquids.	Indoor
<b>NEMA 12k</b>	Same as NEMA 12 - with knockouts.	Indoor
<b>NEMA 13</b>	Dust, spraying water and oil, and noncorrosive coolant fluids.	Indoor

the transformer is energized under conditions of no secondary load. The magnitude of the inrush current is also affected by the point in the AC sine wave in which the transformer power is switched on.

Because of this short duration burst, overcurrent protective devices supplying transformer primaries should be of the time-delay type. Proper overcurrent protection will minimize "nuisance" trips attributed to transformer inrush. Please consult your Dongan Representative or Dongan Customer Service for further advice on any inrush related questions.

### Computations with Impedance:

Impedance is the vector sum of the reactance and resistance limiting current flow in an AC circuit. Impedance in transformers is expressed as a percentage and is indicated on nameplates as % IZ. Most distribution transformers have impedance ranges of from 3% to 8%. Impedance is determined

## Transformer Terms and Definitions

by inherent characteristics of the transformer including kVA, wire size, and other design considerations.

The most important calculations using impedance are those used in determining interrupting capacity of primary overcurrent devices (fuses and circuit breakers). For example, suppose you are required to determine the interrupting capacity of a single phase, 15 kVA transformer with 5% impedance connected to a 480 volt supply.

Determine:

*Full Load Amps (FLA):*

$$FLA = \frac{\text{Nameplate kVA} \times 1000}{\text{Primary Supply Voltage}}$$

$$FLA = \frac{15 \times 1000}{480}$$

$$FLA = 31.25 \text{ Amps}$$

Next Determine:

*Maximum Short Circuit Current*

$$= \frac{\text{Full Load Amps}}{\text{Impedance}}$$

$$= \frac{31.25}{5\%}$$

$$= \frac{31.25}{.05}$$

$$= 625 \text{ Amps}$$

This calculation confirms that the minimum interrupting capacity of the fuse or circuit breaker must be no less than 625 amps at 480 volts.

Now suppose you are required to determine the interrupting capacity of a three phase, 30 kVA transformer with 6% impedance connected to a 480 volt supply.

Determine:

*Full Load Amps (FLA):*

$$FLA = \frac{\text{Nameplate kVA} \times 1000}{\text{Primary Supply Voltage} \times 1.732}$$

$$FLA = \frac{30 \times 1000}{480 \times 1.732}$$

$$FLA = 36.08 \text{ Amps}$$

Next Determine:

*Maximum Short Circuit Current*

$$= \frac{\text{Full Load Amps}}{\text{Impedance}}$$

$$= \frac{36.08}{6\%}$$

$$= \frac{36.08}{.06}$$

$$= 601.3 \text{ Amps}$$

This calculation confirms that the minimum interrupting capacity of the fuse or circuit breaker must be no less than 601.3 amps at 480 volts.

## Transformer Operations

### Overloading Transformers:

The life of a transformer is dependent on the life of its insulation. Transformers loaded in excess of nameplate rated kVA develop excessive heat. Excessive heat will lead to degradation of the insulation system and premature failure of the transformer. For this reason, transformers should not be overloaded. Transformers should be sized with future loads in mind to reduce the possibility of overloading and consequently reducing service life.

### Operation of transformers in ambient temperatures exceeding 40°C:

Operating transformers in ambient air exceeding 40°C will reduce operational life unless the transformer is allowed to operate under conditions of reduced maximum load. The chart below indicates recommended derating for various ambient temperatures. While special designs for high ambient temperatures can be supplied, standard transformers derated are both more economical and more readily available. Consult the factory for ambient temperatures exceeding 60°C.

Maximum Ambient Temperature	Maximum Percentage of Loading
40° C (104° F)	100 %
50° C (122° F)	92 %
60° C (140° F)	84 %

Chart 1.3

## Transformer Terms and Definitions

DONGAN ELECTRIC MANUFACTURING CO. • 2987 FRANKLIN • DETROIT, MI 48207  
 800.428.2626 • 313.567.8500 • FAX 313.567.8828 • www.dongan.com

### Operation of transformers at frequencies other than 60 Hz:

Any transformer rated for use with 50 Hz, or 50/60 Hz distribution systems, is suitable for operation at either 50 Hz or 60 Hz. Transformers rated for operation at 60 Hz only are **not** suitable for operation at 50 Hz due to core saturation. This causes higher losses and excessive heat inherently created in transformers not engineered for 50 Hz applications.

Dongan transformers rated 50/60 Hz and 60 Hz are suitable for operation at frequencies up to and including 400 Hz provided supply voltages do not exceed rated nameplate voltages. Transformers used at 400 Hz will have output voltages slightly higher than output voltage at standard frequency ratings, and voltage regulation at 400 Hz will be slightly less accurate.

General purpose transformers are designed to change voltage. They are **not** capable of changing, or converting frequency from one value to another. Frequency converters or generators are necessary if frequency conversion is required.

### Operation of transformers at other than nameplate voltages:

Transformers must **not** be operated at voltages higher than indicated on the nameplate. The only exception to this rule is when Full Capacity Above Normal (FCAN) taps are provided to accommodate higher voltage.

Transformers may be operated at lower than nameplate voltage provided the transformer's capacity is derated in the same ratio as the voltage reduction. For instance, suppose a 5 kVA transformer with a 480 volt primary and 240 volt secondary is connected to a 240 volt source, resulting in a 120 volt output. Since the transformer capacity must be derated in the same ratio as the voltage, the capacity for this example will be 2.5 kVA, or a 50% reduction.

### Balanced Loading of Single Phase, 120 / 240 Volt Secondaries:

Many single phase transformers are wound with 120 / 240 volt secondaries suitable for 3 wire, 120 / 240 volt service. This feature means that the transformer is wound with 2 separate 120 volt windings designed for series or parallel connection. When these 120 volt windings are connected in series, the transformer is capable of delivering both 120 and 240 volts simultaneously. It is important to assure that each 120 volt winding is not overloaded since each 120 volt winding is designed to carry only one-half of the nameplate kVA of the transformer.

Loading on each 120 volt winding is determined by adding the 120 volt load(s) plus one-half of the 240 volt load.

Example:

Suppose we have a 10 kVA transformer with multiple single phase loads of both 120 and 240 volts as follows:

- 120 volts, 2 kVA
- 120 volts, 1 kVA
- 120 volts, 1 kVA
- 240 volts, 6 kVA

The load must be divided so as not to overload any winding. The diagrams below indicate correct and incorrect connection methods.

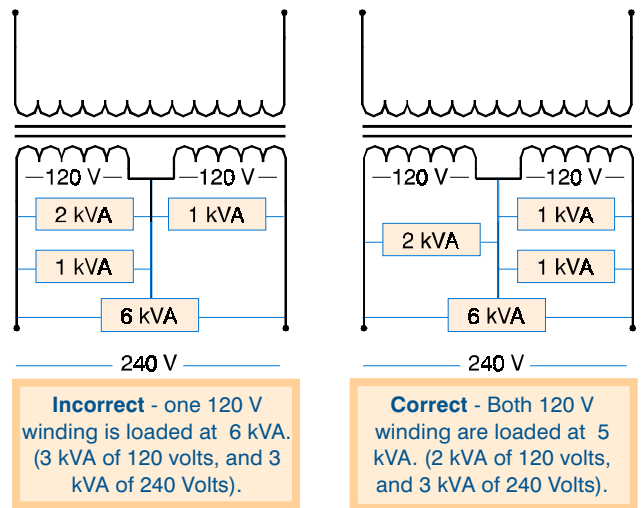

### Balanced Loading of Three Phase Transformers:

Three phase transformers have balanced loading considerations similar to single phase in that no phase can be overloaded. Each phase must not be loaded at more than one-third of the nameplate kVA of the transformer. For example, a 30 kVA transformer may be loaded at no more than 10 kVA per phase (one-third of 30 kVA). Load per phase is determined by adding the single phase load on any phase plus one-third of the total three phase load.

Suppose we have a three phase, 30 kVA transformer with a 208 Y/120 secondary and multiple single and three phase loads as follows:

- 120 volts, 4 kVA, single phase
- 120 volts, 2 kVA, single phase
- 120 volts, 6 kVA, single phase
- 120 volts, 5 kVA, single phase
- 208 volts, 9 kVA, three phase

The load must be divided so as not to load any phase at more than 10 kVA. The diagram on the next page indicates correct and incorrect connections.



## Transformer Terms and Definitions

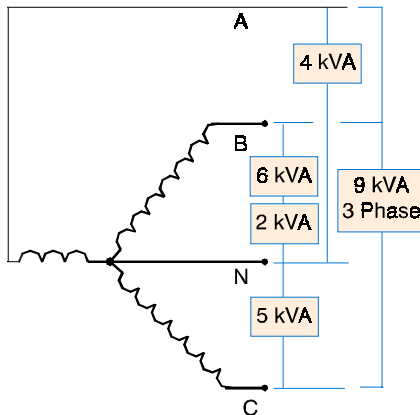

**Incorrect** - Phase B has a total load of 11 kVA when the maximum allowed is 10 kVA

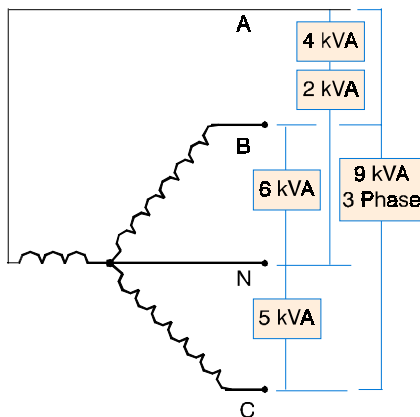

**Correct** - Phase A Load = 9 kVA,  
Phase B Load = 9 kVA, and  
Phase C Load = 8 kVA

### Balanced Loading of a Three Phase Transformer with a Center Tapped 240 Volt Delta Winding:

A common application for three phase transformers with a 240 volt Delta, center tapped winding is to provide power for three phase 240 volt loads and single phase 120 volt lighting loads at the same time. Balanced loading is essential to assure transformer life is not compromised.

For example, suppose a 45 kVA, three phase transformer is to have 36 kVA of three phase load. We know that each phase can carry one-third of the total nameplate kVA (15 kVA), and that the three phase load splits one-third per phase. In this example, each phase would see one-third of 36 kVA, or 12 kVA per phase. This means that no more than 3 kVA of single phase load can be applied to the center tapped leg.

Additionally, the single phase load must be equally divided on either side of the center tap so that 1.5 kVA is connected between X0 and X2 and 1.5 kVA is connected between X0 and X3.

As you can see, applications of this type can severely limit three phase capacity. For this reason, we recommend single phase loads not exceed 5% of nameplate capacity. Installers should consider the use of a separate single phase transformer when single phase loads are excessive.

### Duty Cycle:

Transformers produce heat during the course of normal operations. Some of the heat produced is directly related to the amount of load amps drawn on the transformer. Duty cycle refers to the percentage of time the transformer is loaded to its maximum capacity as opposed to not supplying a load.

Duty cycle is usually expressed over a period of an hour, not including continuous shutdown periods (overnight, weekends, etc.). Therefore, the duty cycle refers to the amount of time the transformer is producing maximum heat output vs. the amount of time it has to cool off again. The most severe duty cycle is, of course, 100%. In some cases, transformers must be oversized in severe duty cycle applications, and in a few cases they can be down sized for light duty cycles.

The most important application of duty cycle is in motor operation, where duty cycle must be considered along with motor starting cycles. A situation where a motor runs almost continuously, (say, 85%) but starts several times per hour will require an oversized transformer. This is because the starting current will cause a momentary overload, with attendant heat buildup, which cannot be cleared from the transformer due to the high duty cycle percentage.

Dongan's technical and customer service staff can advise you on proper transformer sizing where severe duty cycle and/or frequent motor starts are involved.

### Operating Transformers with Motor Loads:

Transformers are well suited for providing power for motor load applications provided a few sizing considerations are followed.

Typical motors have inrush loads of 5 to 10 times their running load requirements. Momentary inrush loads of this magnitude will cause a similar momentary transformer output voltage drop.

Lower transformer output voltage results in lower torque and lower horsepower output of the motor proportionate to the square of the voltage drop. For example, if the voltage drops to 90% of normal, torque and horsepower would be 81% of normal ( $90\%^2 = 81\%$ )

Should the output voltage seen by the motor fall below 50% of nameplate requirements, overheating and even failure of both motor and/or transformer



## Transformer Terms and Definitions

could result. Overheating and failure can occur even in cases where correctly sized overcurrent devices employed in the circuit do not trip.

For this reason, transformers should be sized with a few rules in mind.

- For applications where one transformer is powering one motor, size the transformer so that the motor's running amps do not exceed 66% of the transformer's maximum full load amps.
- For applications of more than one motor being powered by the same transformer, motor start up should be sequenced so that the motors do not start at the same time. If sequencing is not practical, size the transformer so that the combined running amps of all motors do not exceed 66% of the transformer's maximum full load amps.
- Increase transformer kVA by 20% when motors are started more than once per hour.
- Derate transformer kVA by .3% for each 330 feet over 3300 feet above sea level.

### **Parallel Operation:**

Transformers may be operated in parallel banks to achieve higher ampacities under the following circumstances:

- Transformer winding voltages must be exactly equal. If there is an imbalance in voltage, excessive current caused by the voltage imbalance will circulate through the transformer bank, creating heat which will quickly destroy the transformer bank.
- Transformer impedances must be the same.
- Internal and external polarity must be identical on all connections.
- Ampacities of the transformers add arithmetically: two 3 kVA transformers in parallel give a 6 kVA capacity.
- In addition to the above, three phase transformers must have the same angular displacement and phasing.

In short, the safest way to achieve parallel operation is to use identical transformers of the same manufacturer.

### **Single-Phase Transformers used for Three-Phase Banks:**

Single phase, stock, general purpose transformers may be banked to achieve a variety of three phase voltage combinations. These combinations are achieved by connecting two or three identical 240/480 volt, or 600 volt primary, single phase transformers into three phase banks. These *banks provide isolation between primary and secondary* just as a three phase, general purpose transformer would.

Typically, banks of three single phase transformers are connected in a Delta Primary and Delta Secondary, or a Delta Primary and Wye Secondary configuration. The capacity of the three unit, three phase bank is equal to the sum of the individual

single phase kVA ratings. For example, three single phase 10 kVA transformers connected in this manner will have a capacity of 3 x 10 kVA - or 30 kVA, three phase.

Conversely, two transformer banks are connected almost solely in an Open Delta (Delta Primary and Delta Secondary) configuration. The capacity of the 2 unit, three phase bank is equal to the sum of the individual single phase kVA ratings multiplied by 86.6% (.866). For example, two single phase 10 kVA transformers connected in this manner will have a capacity of 2 x 10 kVA x .866 - or 17.3 kVA, three phase.

### **Three Phase to Single Phase:**

Transformers will not "convert" three phase to single phase.

A single phase transformer may be connected to a three phase source to furnish single phase power. The primary of the single phase transformer is connected to any two of the three phase lines, or in the case of a wye service, to any phase line and the neutral. Primary voltage of the single phase transformer must be chosen appropriately to match phase-to-phase or phase-to-neutral voltages of the three phase source.

Caution must be exercised to avoid unbalanced loading of the three phase system supplying power to these types of circuits. Examine all connected loads at the three phase source before proceeding.

### **Single Phase to Three Phase:**

Three phase power requires a three phase source. You cannot use any combination of transformer "magic" to produce three phase power from a single phase source. When this is required, a rotating phase adder or a special inductive/capacitive device called a phase converter must be used. This is a highly specialized area, and equipment for this purpose should be specified with the advice of firms supplying the phase change equipment.

### **Single-Phase Transformers used for Two-Phase Operation:**

While it is seldom seen, there are areas, particularly on the East Coast, where two phase power is still supplied by utility companies. Three phase equipment can be operated from a two phase service by using a specialized transformer system called a "Scott-connected two-to three phase transformer bank".

Dongan Electric designs and builds these special-order units for customers on a regular basis. If two-phase power is found or suspected, please consult with our Engineering Department, because there are several different wiring configurations found, and transformer banks designed for each may be incompatible with the others.

## Transformer Terms and Definitions

### **Reverse Connecting Transformers:**

Because transformers are based on the ratio of turns between two windings insulated from each other, it would appear that there should be no problem with using what is designated as the primary for the secondary, and vice versa. For instance, someone needing 480 volts from a 120 volt source should be able to use a transformer designed to transform 480 volts to 120 volts wired backwards.

Most transformers sized 1 kVA and above in this catalog can be used in this manner. However, because of certain design limitations inherent in transformers below 1 kVA, these should not be reverse connected without checking with our engineering staff. Small transformers are usually made with a "turns compensation" to help offset losses. This compensation will result in an output voltage that is significantly lower than the primary voltage shown on the nameplate if the transformer is reverse connected.

### **Single Phase Transformers used for Autotransformer Zig-Zag Ground Connections:**

Three single phase isolation transformers may be connected into a three phase, Zig-Zag bank to obtain 277 volts by creating a neutral from an existing 480 volt, three phase, three wire service. Please see Page 45 for details on this convenient and economical hookup.

### **Other Autotransformer Connections:**

There are many applications where single phase transformers are conveniently used as autotransformers for both single phase connections and three phase banked connections. Typical three phase autotransformer banks may be found in this catalog in the Three Phase Specialty Application Section on Page 42 and include 600 to 480, 480 to 240, and 380 to 240.

Common single phase applications include using a standard General Purpose transformer with a 240 x 480 volt primary and a 120 / 240 volt secondary to step 480 to 240, single phase, autotransformer connected. When used in this manner, the transformer's nameplate kVA doubles from its original isolation transformer rating. For example, when autoconnected, a 3 kVA transformer will have a capacity of 6 kVA.

### **Harmonics:**

Most electrical and electronic equipment that is not a pure resistive or pure inductive load generates some amount of harmonic distortion of the basic sine wave of the power system. These nonlinear devices can generate levels of harmonic distortion that are significant enough to cause problems for three phase transformers with wye-connected

secondaries. The SCR's found in switchmode power supplies commonly found in all types of electronic equipment today are a major source of this harmonic distortion. Electronic equipment is often connected between a phase and the neutral, and the harmonic currents generated vary between the phases.

This imbalance in harmonic current generates heat in the transformer because of extra neutral currents and eddy current losses in the core. The effect of these nonlinear loads is expressed as a K-factor, with a totally linear load having a K-factor of 1. Loads generating harmonics can have K-factors ranging from K=4 to K=50, with K=20 being the most severe load commonly encountered. Dongan transformers can be custom-made to serve three phase wye loads with K-factors; please contact us for details.

### **Motor Drive Isolation Transformers:**

Transformers for Motor Drive Isolation are specifically designed with additional cooling; the windings are designed with additional support so as to better withstand the constant physical stress on them caused by the heavy loads that occur each time the thyristors in the drive fire. They are also shielded to keep the electrical noise created by the drive unit from radiating back through the transformer into the building's power system.

### **Ordering a Transformer:**

Several parameters must be established when specifying a transformer:

1. Phase Requirements (single or three phase).
2. Line Voltage from source.
3. Load Voltage of load connected to transformer.
4. Frequency (in Hertz) of current source. This must match frequency requirements of connected load!
5. Load amps of connected load.
6. Type of service: General Purpose, Industrial Control, in which the transformer is either open or enclosed.

In most cases, transformers may be selected by answering these six questions. Additional help in sizing transformers is provided in each section of this catalog.

Special applications may require additional information for sizing. Such cases might include installations where the power factor is less than unity, harmonics are present in significant amounts, motors are started and stopped frequently, high ambient temperatures (above 40°C), or special a temperature rise is desired.

In such instances, your Dongan Representative will assist you or you may contact Dongan Customer Service for additional help.



## Transformer Terms and Definitions

DONGAN ELECTRIC MANUFACTURING CO. • 2987 FRANKLIN • DETROIT, MI 48207  
 800.428.2626 • 313.567.8500 • FAX 313.567.8828 • www.dongan.com

### Receipt and Handling:

Upon receipt of shipment, dry type transformers should be thoroughly inspected for any external or hidden damage. In the event a product is found to be damaged, contact the delivering carrier to file a claim and notify your local Dongan Representative. Save all shipping cartons, crates, and/or skids for inspection by the delivering carrier.

Transformers may be extremely heavy. Care must be taken when moving, lifting, and handling to avoid damage to either the transformer or the lifting apparatus. Ventilated, cabinet style transformers must not be tipped over during movement. Lift truck forks should be placed under the skid provided to avoid enclosure damage.

Lifting provisions are provided on many transformers. In some cases, the enclosure top cover must be removed to access lifting provisions provided on the core brackets.

### Installation:

Dry-type transformer installations must comply with all applicable national and local codes for overcurrent protection, enclosure bonding, grounding, etc. Particular attention must be given to assure all installations are provided with adequate clearance from walls and ceilings, and ventilation is sufficient to provide for free air circulation in and around each transformer. Transformers installed in rooms must have enough ventilation to maintain ambient air temperatures within established insulation temperature limits when measured at or near the transformer ventilation openings or enclosure.

Accessibility to the transformer must be considered when locations for transformers are selected. Whenever possible, installation should be away from high traffic areas. Placement must allow unrestricted access to covers and panels for inspection, maintenance, and testing. In addition, area must be provided to allow installation of guards for maintenance personnel and, if necessary, for the removal of the transformer without major disassembly of other components.

Outdoor applications should be in areas where water will not pond or flood into or around the enclosure or connections. Enclosure ratings must be appropriate for outdoor use.

### Grounding:

The *National Electric Code*<sup>®</sup>, Articles 250 and 450, NEMA ST 20 and local electrical codes mandate methods and practices for providing adequate and appropriate conductor grounds and enclosure bonds.

Grounding is important because it increases the safety of the installation by permitting a path to ground should the transformer's coil make contact with the transformer core or enclosure and for passing accumulated static charge buildup to

ground. Proper grounding in transformer installations is essential in increasing the safety of personnel.

Grounding conductors are sized in accordance with the above cited codes. All ground connections must be free of paint and nonconductive materials including rust, dust and corrosion. In addition, connections must be tight at all points in order to maintain adequate bonds throughout.

### Installing to minimize "Hum":

All energized transformers hum due to the alternating magnetic field in the transformer's core. Dongan transformers are designed to minimize this noise. While transformer noise is not avoidable, certain installation techniques will reduce noise complaints.

A transformer should be installed where it will be the least objectionable. This is generally away from quiet areas of a facility. If the ambient sound levels are required to be quieter than the transformer's rated sound output, move the transformer to a remote or noisier area. In addition, transformers should be installed where sound will not reflect from close surfaces such as nearby walls, ceilings or floors.

Installations should not be chosen that will resonate sound. This might occur on thin walls or structures on which the transformer is mounted or from rigid conduit connections. The best installations are those that most effectively isolate the transformer from its surrounding support structures and connections.

Dongan transformers comply with ANSI and NEMA standards for sound requirements. These standards establish maximum sound levels for various transformer kVA ratings as listed in the chart.

Transformer kVA Range	Average Sound Level (Decibels)
0 - 9	40
10 - 50	45
51 - 150	50
151 - 300	55
301 - 500	60

### Maintenance:

Periodic maintenance should be performed by qualified personnel only. Ventilated openings and transformer enclosures must be kept free of dust and debris so as not to restrict the free flow of air throughout the transformer. Periodically the unit should be de-energized and checked for loose connections and internal collections of dust and dirt. Dust may be removed with the use of compressed air or with a vacuum cleaner.

In addition, when de-energized, the transformer may be periodically checked for terminal alignment, pitted or corroded terminals or wires, and tightness and condition of ground connections, mounting bolts and all other hardware.

## Sizing Transformers

Determine the information below in order to select the correct General Purpose transformer for your application. Reference tables, sizing formulae, kVA, amps, and motor horsepower are provided on the

following page. Any questions on sizing may be handled by your Dongan Representative or by contacting Dongan Customer Service at ( 800 ) 428 - 2626.

Required Data	Explanation:	Examples	
		Single Phase	Three Phase
<b>Phase Requirements</b>	Determine load phase requirements <ul style="list-style-type: none"> <li>• Single phase</li> <li>• Three phase</li> </ul>	<b>1 Phase</b>	<b>3 Phase</b>
<b>Line Voltage</b>	Determine the supply or line voltage at the installation site where the transformer will be connected. This is best accomplished by measuring the voltage with a suitable voltmeter.	<b>480 volts</b>	<b>480 volts</b>
<b>Load Voltage</b>	Determine the voltage you require to operate the load to be connected to the transformer. If you are unsure of the correct voltage, check the nameplate of the devices intended for operation. If three phase, check for delta (3 wire) or wye (4 wire) connections.	<b>120 volts</b>	<b>240 volts Delta</b>
<b>Frequency</b>	Be certain the supply line frequency and the load frequency required are the same. Remember: a transformer is not capable of changing frequency.	<b>60 Hz</b>	<b>60 Hz</b>
<b>Load Amps or kVA</b>	Determine either load kVA or load amps by adding all loads to be supplied by the transformer. This is best accomplished by again referring to the equipment nameplates.	<b>20 amps = 2.4 kVA Single Phase</b>	<b>75 amps = 31.1 kVA Three Phase</b>
<b>Select Correct Catalog No. from Charts</b>	Now turn to the appropriate single or three phase chart. Select the column closest to the line/load voltage combination for your application. Move down the column until values of load kVA or load amps meet or exceed your load amps or load kVA required. Never size smaller than your requirements demand. Then read across the row to select the correct catalog number for your application.	<b>Cat No. 80-1050 or 85-1050SH = 3 kVA</b>	<b>Cat No. 63-6245SH = 45 kVA</b>
<b>Connect Transformer per Supplied Diagrams</b>	The transformer may now be connected per the diagram indicated.	<b>Diagram 1 or Diagram 4 Pg. 15</b>	<b>Diagram 5 Pg. 32</b>





# Sizing Transformers

DONGAN ELECTRIC MANUFACTURING CO. • 2987 FRANKLIN • DETROIT, MI 48207  
 800.428.2626 • 313.567.8500 • FAX 313.567.8828 • www.dongan.com

## HOW TO DETERMINE TRANSFORMER kVA RATINGS

### Transformer Load expressed in amperes:

Select the appropriate kVA size from the selection charts listed on this page or by using the single phase or three phase sizing formula listed below. Be sure to select a transformer kVA rating equal to or greater than the anticipated connected load.

$$\text{Single Phase kVA} = \frac{\text{Load Voltage} \times \text{Load Amps}}{1000} \quad \text{kVA} = \frac{\text{Volt Amperes}}{1000}$$

$$\text{Three Phase kVA} = \frac{\text{Load Voltage} \times \text{Load Amps} \times 1.73}{1000} \quad \text{VA} = \text{kVA} \times 1000$$

### Transformer Load expressed in kVA:

Select the appropriate size from the selection charts. Be sure to select a transformer kVA rating equal to or greater than the anticipated connected load.

### Transformer Load expressed in wattage:

Convert wattage into a kVA rating by using the formula listed below. Or you may refer to the equipment nameplate to obtain the ampere requirements of the connected load. Be sure to select a transformer kVA rating equal to or greater than the anticipated connected load.

$$\text{kVA} = \frac{\text{Wattage}}{(1000 \times \text{Power Factor of the Load})}$$

### Transformer Load expressed in motor horsepower:

Select the appropriate size kVA rating from the motor horsepower charts on this page. Be sure to select a transformer kVA rating equal to or greater than the anticipated load requirements.

#### Note:

**High Ambient Temperature Applications:** Derate the transformer nameplate kVA 8% for each 10°C above 40°C up to 60°C. Consult factory for ambients above 60°C.

**High Altitude Applications:** To allow for reduced cooling at higher elevations derate the transformer nameplate kVA by .3% for each 330 feet over 3300 feet above sea level.

kVA / Ampacity Ratings for Single Phase AC Voltages													
kVA	12V	16V	24V	32V	48V	120V	208V	240V	277V	380V	415V	480V	600V
.050	4.2	3.1	2.1	1.6	1.0	.42	.24	.21	.18	.13	.12	.10	.08
.100	8.3	6.2	4.2	3.3	2.0	.83	.48	.42	.36	.26	.24	.21	.17
.150	12.5	9.4	6.3	4.6	3.1	1.3	.72	.63	.54	.39	.36	.31	.25
.250	20.8	15.6	10.4	7.8	5.2	2.1	1.2	1.0	.90	.66	.60	.52	.42
.500	41.7	31.2	20.8	15.6	10.4	4.2	2.4	2.1	1.8	1.3	1.2	1.0	.83
.750	62	47	31.3	23.4	16.6	6.3	3.6	3.1	2.7	2.0	1.8	1.6	1.3
1	83	62	41.7	31.2	20.8	8.3	4.8	4.2	3.6	2.6	2.4	2.1	1.7
1.5	125	94	62	47	31.2	12.5	7.2	6.3	5.4	3.9	3.6	3.1	2.5
2	166	125	83	62.5	41.6	16.7	9.6	8.3	7.2	5.3	4.8	4.2	3.3
3	250	188	125	94	62	25.0	14.4	12.5	10.8	7.9	7.2	6.3	5.0
5	416	312	208	156	104	41.7	24.0	20.8	18.1	13.2	12.0	10.4	8.3
7.5						62	36.1	31.3	27.1	19.7	18.1	15.6	12.5
10						83	48.1	41.7	36.1	26.3	24.1	20.8	16.7
15						125	72	62	54	39.5	36.1	31.3	25.0
25						208	120	104	90	65	60	52	41.7
37.5						312	180	156	135	98	90	78	62
50						416	240	208	180	131	120	104	83
75						625	360	312	270	197	180	156	125
100						833	480	416	361	263	240	208	166

kVA / Ampacity Ratings for Three Phase AC Voltages								
kVA	200V	208V	240V	380V	415V	480V	575V	600V
3	8.6	8.3	7.2	4.5	4.1	3.6	3.0	2.8
6	17.3	16.6	14.4	9.1	8.3	7.2	6.0	5.7
9	26.0	25.0	21.6	13.6	12.5	10.8	9.0	8.6
15	43.3	41.6	36.1	22.8	20.8	18.0	15.0	14.4
25	72	69	60	38.0	34.8	30.1	25.1	24.0
30	86	83	72	45.6	41.7	36.1	30.1	28.9
45	130	125	108	68	62	54	45.2	43.3
75	216	208	180	114	104	90	75	72
112.5	325	312	270	171	156	135	113	108
150	433	416	361	228	208	180	150	144

Full Load Amperes - Single Phase AC Motor Voltages						
HP	115V	200V	208V	230V	Minimum Transformer kVA	Std. Dongan Size
1/6	4.4	2.5	2.4	2.2	.53	.750
1/4	5.8	3.3	3.2	2.9	.70	.750
1/3	7.2	4.1	4.0	3.6	.87	1
1/2	9.8	5.6	5.4	4.9	1.18	1.5
3/4	13.8	7.9	7.6	6.9	1.68	2
1	16	9.2	8.8	8	1.92	2
1 1/2	20	11.5	11	10	2.40	3
2	24	13.8	13.2	12	2.88	3
3	34	19.6	18.7	17	4.10	5
5	56	32.2	30.8	28	6.72	7.5
7 1/2	80	46	44	40	9.60	10
10	100	57.5	55	50	12.0	15

Full Load Amperes - Three Phase AC Motor Voltages						
HP	208V	230V	460V	575V	Min. Transformer kVA	Std. Dongan Size
1/2	2.4	2.2	1.1	.9	0.9	3
3/4	3.5	3.2	1.6	1.3	1.2	3
1	4.6	4.2	2.1	1.7	1.5	3
1 1/2	6.6	6.0	3.0	2.4	2.1	3
2	7.5	6.8	3.4	2.7	2.7	3
3	10.6	9.6	4.8	3.9	3.8	6
5	16.7	15.2	7.6	6.1	6.3	9
7 1/2	24.2	22	11	9	9.2	15
10	30.8	28	14	11	11.2	15
15	46.2	42	21	17	16.6	25
20	59.4	54	27	22	21.6	25
25	74.8	68	34	27	26.6	30
30	88	80	40	32	32.4	45
40	114	104	52	41	43.2	45
50	143	130	65	52	52	75
60	169	154	77	62	64	75
75	211	192	96	77	80	112.5
100	273	248	124	99	103	112.5
125	343	312	156	125	130	150
150	396	360	180	144	150	150

#### Note:

Increase transformer kVA by 20% when motors are started more than once per hour.

Multiply motor ampacity by 1.1 and 1.25 respectively for 90% and 80% power factors.



# General Purpose Transformer Overcurrent Protection

The fuse chart below indicates Overcurrent Protection (OCP) requirements for General Purpose transformers. Please refer to NEC® Section 240-3 (i), 450-3 and applicable

local codes for additional details on overcurrent protection practices. The chart applies to transformers rated 600 volts and below.

Feeder Circuit	Phase	No. of Secondary Wires	Primary Current ( $I_p$ )	Primary Protection (% of Pri $I_p$ )	Secondary Current ( $I_s$ )	Secondary Protection (% of Sec. $I_s$ )
No OCP	1	2	Less than 2 2 to less than 9 9 or more	Required 300% Max. 167% Max. 125% *	Not Applicable	Not Required
No OCP	3	3 (Delta-Delta Only)	Less than 2 2 to less than 9 9 or more	Required 300% Max. 167% Max. 125% *	Not Applicable	Not Required
No OCP	1	More than 2	All Values	Required 250% Max.	Less than 9 9 or more	Required 167% 125%*
No OCP	3	More than 3	All Values	Required 250% Max.	Less than 9 9 or more	Required 167% 125%*
Has OCP Meeting Requirements of Note A	1	2	Not Applicable	Not Required	Not Applicable	Not Required
Has OCP Meeting Requirements of Note A	3	3 (Delta-Delta Only)	Not Applicable	Not Required	Not Applicable	Not Required
Has OCP Meeting Requirements of Note B	1	More than 2	Not Applicable	Not Required	Less than 9 9 or more	Required 167% 125%*
Has OCP Meeting Requirements of Note B	3	More than 3	Not Applicable	Not Required	Less than 9 9 or more	Required 167% 125%*

Note A: Overcurrent protection (OCP) must meet the following criteria to qualify:

- Less than 2 amps, maximum of 300% of primary current ( $I_p$ )
- 2 amps to less than 9 amps, maximum of 167% of primary current ( $I_p$ )
- 9 amps or more, 125% of primary current ( $I_p$ ) or next size larger.

Note B: Branch circuit Overcurrent Protection (OCP) can be a maximum of 250% of the Primary Current. If this requirement is not met, then go to the chart section where no Overcurrent Protection (OCP) is provided.

\*If this calculated number does not correspond to a standard fuse size, the next larger size is permitted.

**Section 240-6(a) of the 1996 National Electric Code®** provides a table of standard ampere rating for fuses and fixed trip circuit breakers:

The standard ampere ratings for fuses and inverse time circuit breakers shall be considered 15, 20, 25, 30, 35, 40, 45, 50, 60, 70, 80, 90, 100, 110, 125, 150, 175, 200, 225, 250, 300, 350, 400, 450, 500, 600, 700, 800, 1000, 1200, 1600, 2000, 2500, 3000, 4000, 5000 and 6000 amperes.

Exception: Additional standard ratings for fuses shall be considered 1, 3, 6, 10, and 601.

Reprinted with permission from NFPA 70-1996, the *National Electrical Code®*, Copyright© 1995, National Fire Protection Association, Quincy, MA 02269. This reprinted material is not the complete and official position of the National Fire Protection Association, on the referenced subject which is represented only by the standard in its entirety.



# Warranty

DONGAN ELECTRIC MANUFACTURING CO. • 2987 FRANKLIN • DETROIT, MI 48207  
 800.428.2626 • 313.567.8500 • FAX 313.567.8828 • www.dongan.com

## Warranty

Dongan Electric Manufacturing Company (Dongan), at Dongan's option, warrants to the original purchaser to correct by repair, refund of the original purchase price, or replacement, products that fail within the warranty period cited below.

Standard Catalog Transformers	10 Years
Ignition Transformers	3 Years
Custom Transformers	2 Years

Said warranty applies from the date of manufacture, provided the product has been installed, operated and maintained in accordance with all accepted industry practices and standards, that conditions of operation have been normal at all times, and that the product has not been subjected to any undue stress from excess voltage, frequency, load, or insufficient or inadequate ventilation.

Prompt written notice of any defect must be submitted to Dongan within the warranty period as provided above. The warranty applies on condition that Dongan's examination determines that the warranty claim is valid as submitted by the original purchaser.

Dongan's obligation under this warranty is in lieu of all other warranties expressed or implied including any warranties of merchantability and fitness for purpose and is limited to a refund of the original purchase price, replacement, or repair of the defective product.

Dongan will not be liable for any incidental, consequential, contingent or special damages, including loss of use, function or profits arising out of or in connection with the use of Dongan's products, and shall have no other liability for payment of any other damages. The remedy provided herein is Dongan's entire liability and the purchaser's sole remedy.

## UL, CSA, CE, TÜV FILE NUMBERS BY SERIES

Series	Transformer Type	Phase	kVA	UL File Number	UL Standard	CSA File Number	CSA Standard	CE Marked	TÜV License No.
35, 80	General Purpose	Single Phase	.050 - 5 kVA	E3210	UL 506	LR-560	C22.2, #66, #47		
85	General Purpose	Single Phase	.250 - 10 kVA	E3210	UL 506	E3210	C22.2, #66, #47		
85	General Purpose	Single Phase	15 - 25 kVA	E78234	UL 506	E78234	C22.2, #66, #47		
61	General Purpose	Single Phase	7.5 - 100 kVA	E78234	UL 506	E78234	C22.2, #66, #47		
ES-11	General Purpose	Single Phase	.250 - 25 kVA	E3210	UL 506	E3210	C22.2, #66, #47	EN 60 742	R 9679035.01
33	Control	Single Phase	.050 - .250 kVA	E3210	UL 506	LR 560	C22.2, #66, #47		
36	Signaling	Single Phase	.050 - 1 kVA	E3210	UL 506	LR 560	C22.2, #66, #47		
76	General Purpose	Three Phase	3 -45 kVA	E3210	UL 506	LR 560	C22.2, #66, #47		
63	General Purpose Scott Connected	Three Phase	3 - 9 kVA	E3210	UL 1561	LR 560	C22.2, #66, #47		
63	General Purpose	Three Phase	1 - 150 kVA	E78234	UL 1561	LR 560	C22.2, #66, #47		
ES-31	General Purpose	Three Phase	1 - 40 kVA	E3210	UL 506	E3210	C22.2, #66, #47	EN 60 742	R 9679035.01
63	Motor Drive	Three Phase	3 - 145 kVA	E78234	UL 1561	LR 560	C22.2, #66, #47		
35, 80	Buck - Boost	Single Phase	.050 - 5 kVA	E3210	UL 506	LR 560	C22.2, #66, #47		
85	Buck - Boost	Single Phase	.250 - 5 kVA	E3210	UL 506	E3210	C22.2, #66, #47		
50	Industrial Control	Single Phase	.050 - 5 kVA	E3210	UL 506	LR 560	C22.2, #66, #47		
HC	Industrial Control	Single Phase	.050 - 2 kVA	E3210	UL 506	LR 560	C22.2, #66, #47		
ES-10	Industrial Control	Single Phase	.150 - 25 kVA	E3210	UL 506	E3210	C22.2, #66, #47	EN 60 742	R 9679035.01
AP12, FP12	Industrial Control	Single Phase	.150 - 25 kVA	E3210	UL 1561	E3210	C22.2, #66, #47		
SDA	Servo - Drive Isolation	Single Phase	1.25 - 10 kVA	E78234	UL 1561	LR 560	C22.2, #66, #47		

## Corporate History



The Dongan Electric Instrument Company was established in Albany, New York, as a New York Corporation. Initial products included the manufacture of ammeters and voltmeters for the growing automotive business.

Dongan was acquired in 1909 by Mr. Lyle J. Hicks, who had been working as an electrical engineer for General Electric Company in Schenectady, New York. The Company was moved to Detroit, Michigan in 1911 and renamed Dongan Electric Manufacturing Company, establishing the Company as a Michigan corporation. The Corporate name was taken from Governor Dongan, the first appointed Colonial governor of the Territory of New York in 1682.

The Company quickly began the manufacture of low voltage bell ringing transformers. Some of the first Underwriters' Laboratories approvals are dated February 10, 1911 covering door bell transformers equipped with secondary outputs of 6, 12, and 18 volts. These early products had the additional approvals of the National Board of Fire underwriters. Continued success in the transformer industry led to decisions making transformers the principal product on which the company was to compete.

The Roaring '20's ushered in popular and certainly more affordable console radios. Originally powered by dry-cell "B" batteries, radios were rapidly converted to power tubes. During this time, Dongan introduced radio voltmeters, amplifier transformers, filament heating transformers and chokes compatible with Raytheon, R.C.A., and Cunningham radio tubes. These products were assembled into a package that eliminated B batteries from radios and allowed the radio to be operated from wall outlets.

This decade also saw the emergence of electric toys and trains. The demand for transformers to operate trains manufactured by Lionel, American Flyer, Ives and Bing was met with a series of various sized transformer products from Dongan.

The popularity of neon signs in the '30's created a mark for "luminous tube", or neon transformers. Dongan achieved one of the first Underwriters' Laboratories approval for neon transformers and powered signs across the country including the famed Radio City Music Hall.

Technology moved to provide other opportunities in the '30's as well. Coal fired furnaces began to give way to oil heat. Dongan responded with a complete line of replacement oil burner ignition transformers. The demand for these products became so substantial that a new 8,000 square facility was built in 1957 in Pioneer, Ohio to help meet production requirements. The facility was formed as a wholly owned subsidiary under the name of Pioneer Transformer Company by Charles E. "Bud" Hicks, son of Lyle Hicks.

General purpose power distribution transformers, industrial control and other more specialized designs were gradually added to the product line during the '40's, and '50's. Wartime production included both existing product lines and Department of Defense related parts for gun sights.

More recent products include reactors, constant voltage transformers, K - Rated transformers, transformer lighting disconnects and related products.

Today, Dongan combines our 90 year history of specialty transformer manufacturing expertise with a complete catalog of stock transformers for the distributor, OEM and MRO markets. We are proud of our heritage and look forward to serving our customer base into the new millennium.

DONGAN ELECTRIC MANUFACTURING Co. • 2987 FRANKLIN • DETROIT, MI 48207  
800.428.2626 • 313.567.8500 • Fax 313.567.8828 • www.dongan.com

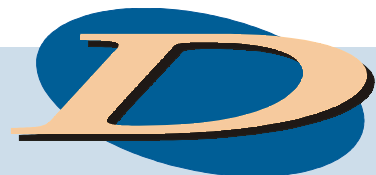



# DONGAN TRANSFORMERS

**DONGAN ELECTRIC MANUFACTURING CO.**



**TRANSFORMER DISCONNECTS**  
For  
Control Panel Lighting and Auxiliary Power

UL and CUL Listed  
TÜV Rheinland Licensed / CE Marked Series



Dongan Electric Manufacturing Co.      Distributed By:  
2987 Franklin St.  
Detroit, MI 48207  
800.428.2626 • 313.567.8500  
Fax 313.567.8828 • www.dongan.com

Transfax 108  
3/10

**Transfax 108**

**DONGAN** IGNITION  
TRANSFORMERS

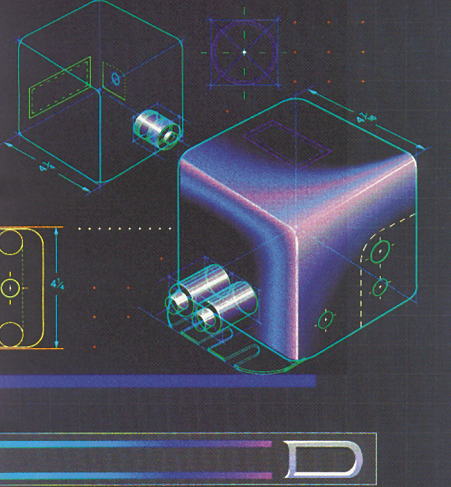

**Bulletin IT-9-92**

**Bulletin IT-9-92**

Transfax 107  
10/96

**Series ES**  
CE Mark transformers

UL and C-UL listed  
TÜV Rheinland licensed



Series ES-10  
single phase



Series ES-11  
single phase



Series ES-31  
three phase

Dongan Electric Mfg. Co.      Distributed by:  
2987 Franklin St.  
Detroit, MI 48207  
800.428.2626

**Transfax 107**

## Dongan Electric Manufacturing Company

2987 Franklin Street  
Detroit, MI 48207  
800.428.2626 • 313.567.8500  
Fax 313.567.8828 • www.dongan.com  
dongan@compuserve.com

### Transfax 108

Transformer Lighting Disconnects  
UL and CSA Listed  
TÜV Rheinland Licensed / CE Marked Series

### Bulletin IT-9-92

Ignition Transformers for Gas & Oil  
UL and CSA Listed  
Industrial & Residential Applications

### Transfax 107

CE Marked Series - Single & Three Phase  
Industrial Control & General Purpose Transformers  
UL and CUL Listed, TÜV Rheinland Licensed

### Pioneer Transformer Company

A Wholly Owned Subsidiary  
500 Cedar Street  
Pioneer, OH 43554